

.....

1505 East High Street
Jefferson City, Missouri 65101
Telephone (573) 659-9078
Facsimile (573) 659-9079

GREDELL Engineering Resources, Inc.

Sikeston Board of Municipal Utilities Sikeston Power Station Fly Ash Pond History of Construction

.....

Prepared for:



Sikeston
Board of Municipal Utilities

**Sikeston Power Station
1551 West Wakefield Avenue
Sikeston, MO 63801**

April 2018

**Sikeston Board of Municipal Utilities
Sikeston Power Station
Fly Ash Pond
History of Construction**

April 2018

Table of Contents

1.0 INTRODUCTION.....	1
1.1 §257.73(c)(1) History of Construction	1
2.0 FLY ASH POND DESCRIPTION	4
3.0 FLY ASH POND CONSTRUCTION	5
3.1 Foundations and Abutments.....	5
3.2 Fly Ash Pond Berms.....	5
3.3 Compacted Clay Liner	6
3.4 Spillways	6
3.5 Instrumentation.....	7
4.0 CHANGES IN CONSTRUCTION OR OPERATION	8
5.0 RECORD OF INSTABILITY	9
6.0 REFERENCES.....	10

List of Appendices

Appendix A	Figures
Appendix B	Historical Construction Drawings
Appendix C	Historical Construction Specifications

1.0 INTRODUCTION

In accordance with the scope of services outlined in the Sikeston Board of Municipal Utilities (SBMU) Work Order No. 18348 dated January 22, 2018, GREDELL Engineering Resources, Inc. (Gredell Engineering) developed a history of construction report for the SBMU Sikeston Power Station (SPS) Fly Ash Pond, a coal combustion residual (CCR) surface impoundment. The purpose of this report is to detail the history of construction of the Fly Ash Pond in accordance with the Code of Federal Regulations, Title 40, Part 257 – Criteria for Classification of Solid Waste Disposal Facilities and Practices, Subpart D – Standards for the Disposal of Coal Combustion Residuals in Landfills and Surface Impoundments (the Federal CCR Rule), Hazardous and Solid Waste Management System: Disposal of Coal Combustion Residuals From Electric Utilities; Extension of Compliance Deadlines for Certain Inactive Surface Impoundments; Response to Partial Vacatur (the Direct Final Rule), for section (§) 40 CFR 257.100 (effective October 4, 2016) and the Federal CCR Rule §257.73(c) (effective October 19, 2015). §257.100 (effective October 4, 2016) and §257.73(c), detailing the requirements of a history of construction report for a CCR surface impoundment, are provided for reference below.

SPS is located in Scott County, Missouri west of Interstate 55 and Sikeston, Missouri. The nearest metropolitan statistical area (MSA) according to the United States Office of Management and Budget is the St. Louis, Missouri – Illinois MSA. SPS can be accessed from the St. Louis MSA in the following manner:

From St. Louis, Missouri, proceed south on I-55 approximately 140 miles to US-60. Take Exit 66B from I-55 South onto US-60 and proceed approximately 8.6 miles west to State Highway FF/BB. Turn right onto State Highway FF/BB and proceed 2.7 miles north to Wakefield Avenue. Turn right onto Wakefield Avenue and proceed 0.7 miles east to the Sikeston Board of Municipal Utilities Power Plant entrance. Turn right into the entrance and proceed south to the guard office.

1.1 §257.73(c)(1) History of Construction

As of the effective date of the Federal CCR Rule (October 19, 2015), if a coal fired power station suspended the disposal of CCR in a surface impoundment prior to October 19, 2015, produced a declaration of the surface impoundment as inactive with the intent to initiate closure by December 17, 2015, and completed closure by April 17, 2018, the inactive surface impoundment was not subject the requirements applicable to existing surface impoundments (§257.100). On June 14, 2016, the D.C. Circuit Court of Appeals ordered the vacatur of the early closure provisions in 40 §257.100. The effect of the vacatur is that inactive surface impoundments must comply with all the requirements applicable to existing surface impoundments. USEPA developed and implemented the Direct Final Rule with an effective date of October 4, 2016 creating an extension

of the compliance deadlines for inactive surface impoundments. §257.100 states the following as of October 4, 2016.

- (a) *Inactive CCR surface impoundments are subject to all of the requirements of this subpart applicable to existing surface impoundments.*

- (e)(1) *An inactive CCR surface impoundment for which the owner or operator has completed the actions by the deadlines specified in paragraphs (e)(1)(i) through (iii) of this section is eligible for the alternative timeframes specified in paragraphs (e)(2) through (6) of this section. The owner or operator of the CCR unit must comply with the applicable recordkeeping, notification, and internet requirements associated with these provisions. For the inactive CCR surface impoundment:*
 - (e)(1)(i) *The owner or operator must have prepared and placed in the facility's operating record by December 17, 2015, a notification of intent to initiate closure of the inactive CCR surface impoundment pursuant to §257.105(i)(1);*
 - (e)(1)(ii) *The owner or operator must have provided notification to the State Director and/or appropriate Tribal authority by January 19, 2016, of the intent to initiate closure of the inactive CCR surface impoundment pursuant to §257.106(i)(1); and*
 - (e)(1)(iii) *The owner or operator must have placed on its CCR web site by January 19, 2016, the notification of intent to initiate closure of the inactive CCR surface impoundment pursuant to §257.107(i)(1).*
 - (e)(3)(iv) *No Later than April 17, 2018, compile a history of construction as set forth by §257.73(b) and (c).*

The history of construction, shall contain, to the extent feasible, the information specified in paragraphs (c)(1)(i) through (xi) of §257.73(c).

- (c)(1)(i) *The name and address of the person(s) owning or operating the CCR unit; the name associated with the CCR unit; and the identification number of the CCR unit if one has been assigned by the state.*

- (c)(1)(ii) *The location of the CCR unit identified on the most recent U.S. Geological Survey (USGS) 7½ minute or 15 minute topographic quadrangle map, or a topographic map of equivalent scale if a USGS map is not available.*

- (c)(1)(iii) *A statement of the purpose for which the CCR unit is being used.*

- (c)(1)(iv) *The name and size in acres of the watershed within which the CCR unit is located.*
- (c)(1)(v) *A description of the physical and engineering properties of the foundation and abutment materials on which the CCR unit is constructed.*
- (c)(1)(vi) *A statement of the type, size, range, and physical and engineering properties of the materials used in constructing each zone or stage of the CCR unit; the method of site preparation and construction of each zone of the CCR unit; and the approximate dates of construction of each successive stage of construction of the CCR unit.*
- (c)(1)(vii) *At a scale that details engineering structures and appurtenances relevant to the design, construction, operation, and maintenance of the CCR unit, detailed dimensional drawings of the CCR unit, including a plan view and cross sections of the length and width of the CCR unit, showing all zones, foundation improvements, drainage provisions, spillways, diversion ditches, outlets, instrument locations, and slope protection, in addition to the normal operating pool surface elevation and the maximum pool surface elevation following peak discharge from the inflow design flood, the expected maximum depth of CCR within the CCR surface impoundment, and any identifiable natural or manmade features that could adversely affect operation of the CCR unit due to malfunction or mis-operation.*
- (c)(1)(viii) *A description of the type, purpose, and location of existing instrumentation.*
- (c)(1)(ix) *Area-capacity curves for the CCR unit.*
- (c)(1)(x) *A description of each spillway and diversion design features and capacities and calculations used in their determination.*
- (c)(1)(xi) *The construction specifications and provisions for surveillance, maintenance, and repair of the CCR unit.*
- (c)(1)(xii) *Any record or knowledge of structural instability of the CCR unit.*

The history of construction is not a requirement of the Federal CCR Rule which requires a certification from a qualified professional engineer.

2.0 FLY ASH POND DESCRIPTION

SPS is located west of the City of Sikeston, south of West Wakefield Avenue, and east of Route BB in Scott County, Missouri. The Fly Ash Pond at SPS resides to the northeast of SPS, directly east of SPS's coal pile and directly north of SPS's Bottom Ash and Scrubber Sludge Pond. The Fly Ash Pond occupies approximately 30 acres with a maximum berm elevation of 322 feet. The Fly Ash Pond was used for the disposal of fly ash from the initiation of plant operations in 1981 to October 18, 2015. By suspending the disposal of CCR in the Fly Ash Pond prior to October 19, 2015, SPS met the Federal CCR Rule requirement to classify the Fly Ash Pond as an inactive CCR surface impoundment.

On June 14, 2016, the D.C. Circuit Court of Appeals ordered the vacatur of the early closure provisions in §257.100. The effect of the vacatur is that SPS's inactive Fly Ash Pond must comply with all the requirements applicable to existing surface impoundments. Due to the obligation to meet the applicable requirements for existing surface impoundments, SPS elected to not continue with the closure of the Fly Ash Pond and resume the disposal of fly ash in the Fly Ash Pond. Based on an aerial survey conducted by Surdex Corporation on May 6, 2012, the Fly Ash Pond has an approximate remaining capacity of 31.2 acre-feet (ac-ft) (135,900 cubic feet [ft³]). General information about SPS and the Fly Ash Pond is provided below.

Name of Owner or Operator: Sikeston Power Station, Sikeston Board of Municipal Utilities

Address of Owner or Operator: 1551 West Wakefield Avenue, Sikeston, Missouri 63801

CCR Unit Name: Fly Ash Pond

CCR State Identification Number: Not Applicable

SPS and the Fly Ash Pond are located at a transition between agricultural and urban areas. The Fly Ash Pond is surrounded by agricultural, commercial, and residential areas. Residential areas are located approximately 350 feet north of the Fly Ash Pond. Commercial areas are located approximately 1,700 feet east of the Fly Ash Pond. The remaining area around the Fly Ash Pond is agricultural land. There is City-owned property to the east of the Fly Ash Pond. The SPS is situated within the Little Rivers Ditches Watershed Hydrologic Unit Code (08020204) which covers approximately 1,676,800 acres in Missouri, Arkansas, and Kentucky. The Fly Ash Pond is constructed above the surrounding landscape, therefore, the Fly Ash Pond does not receive stormwater runoff from the surrounding topography. See Appendix A, Figure 1 – U.S. Geological Survey Topographic Quadrangle Map for the relative location of the Fly Ash Pond and the surrounding topography. See Appendix A, Figure 2 – Aerial View for a depiction of the Fly Ash Pond.

3.0 FLY ASH POND CONSTRUCTION

The construction of the Fly Ash Pond at SPS was conducted between 1978 and 1979. The original ground surface was stripped of top soil, clay, and vegetation to a minimum depth of 6 inches. The surface was then excavated or backfilled to the desired subgrade elevation. The finished subgrade elevation of the Fly Ash Pond was 300 feet. The Fly Ash Pond was lined with a two-foot thick compacted clay liner (CCL) on the bottom and interior slopes. The bottom, interior, and exterior slopes of the Fly Ash Pond berms were covered with a 4-inch thick layer of topsoil which was subsequently seeded, mulched, and netted to protect against erosion. A description of the construction materials and methods for the foundations and abutments, berms, spillways, and instrumentation is provided below.

3.1 Foundations and Abutments

The foundation soils for the Fly Ash Pond consist of existing soils or fills compacted to support the finished construction of the Fly Ash Pond. Topsoil and soil with unsuitable material was stripped to a minimum depth of 6 inches. The stripped surface was excavated or filled to the grades depicted on the construction drawings (see Appendix B – Historical Construction Drawings). The foundation soils beneath the berms of the Fly Ash Pond consist of silty sand (SM) and fine to medium course sand (SP) (Geotechnology 2011).

The foundation soils were assumed to be prepared in accordance with the construction specifications. The foundation soils were prepared for embankment fill by roller compaction to a 95 percent (%) maximum density at optimum moisture for silty sands and 70% relative density for sands. The top 6 inches of the foundation soils were subsequently roughened then wetted or dried as required to insure an adequate bond with the embankment fill material prior to the construction of features of the Fly Ash Pond. The construction specifications may be found in Appendix C – Historical Construction Specifications.

3.2 Fly Ash Pond Berms

The berms of the Fly Ash Pond were constructed on top of the prepared foundation soils. The berm fill material consisted of fine sands and silty sands (SP and SM) (Geotechnology 2011). The berm fill materials were assumed to be placed in 12-inch maximum loose lifts and compacted to a 70% relative density in accordance with the construction specifications (see Appendix C – Historical Construction Specifications). The berms were constructed with 2 horizontal to 1 vertical slopes (2H:1V). The finished top elevation of the berms was 322 feet.

The interior slopes of the Fly Ash Pond were covered with a 2-foot thick CCL which was subsequently covered with a 4-inch thick layer of topsoil. The finished interior slopes were seeded and mulched to provide slope protection. The exterior slopes of the Fly Ash Pond berm fill

material were covered with a 4-inch thick layer of topsoil and subsequently seeded and mulched to provide slope protection.

The eastern and northern berm exterior slopes of the Fly Ash Pond were buttressed by the coal rail loop berm. The coal rail loop berm is constructed of the same fill materials and in the same manner as the Fly Ash Pond berm to a top elevation of 310 feet. A flat bottom stormwater ditch varying in width from 2 feet to 8 feet 6 inches was constructed along the interior perimeter of the coal rail loop. The slope of the stormwater ditch was constructed at 0.15 percent (%). The flat bottom stormwater ditch utilized two drop inlet structures to route stormwater runoff. One drop inlet structure is located along the northern side of the Fly Ash Pond and discharges stormwater north to the stormwater ditch along the southern side of West Wakefield Avenue. The second drop inlet structure is located along the eastern side of the Fly Ash Pond and discharges stormwater to the stormwater ditch along the eastern side of the Fly Ash Pond which ultimately discharges stormwater to the stormwater ditch along the southern side of West Wakefield Avenue.

3.3 Compacted Clay Liner

The interior slopes of the Fly Ash Pond were constructed with a CCL. The CCL material was obtained from various borrow sources both on- and off-site. The CCL was constructed with a minimum thickness of 2 feet of clay material with a coefficient of permeability of 3.2×10^{-7} centimeters per second (see Appendix B – Historical Construction Drawings).

The top 6 inches of the embankment fill materials were roughened then wetted or dried as required to insure an adequate bond with the clay liner material prior to the construction of CCL. The CCL was assumed to be constructed in 8-inch maximum loose lifts and compacted to a 95% maximum density at optimum moisture in accordance with the construction specifications (see Appendix C – Historical Construction Specifications). The CCL was assumed to be installed to the extents depicted on the historical construction drawings (see Appendix B – Historical Construction Drawings). After construction was complete, the Fly Ash Pond was filled with water to a minimum depth of 6 feet to protect the CCL against hydrostatic uplift pressure.

3.4 Spillways

The Fly Ash Pond was constructed with an overflow structure through the Fly Ash Pond's northern and western berms. The overflow structure consisted of a concrete structure with the water level controlled by stop logs. The overflow water can be diverted to the southern stormwater ditch along West Wakefield Avenue through Overflow #1, or to the Process Waste Pond through Overflow #2.

Overflow #1 is a 24-inch ductile iron pipe (inlet and discharge elevations of 316.42 feet and 316.38 feet respectively) which discharges through a 24-inch Kennison nozzle (for measuring and recording flow) into an approximate 8-foot by 10-foot concrete vault. The discharge from the concrete vault is through a 24-inch corrugated metal pipe (CMP) (inlet and discharge elevations of 313.0 feet and 305.0 feet respectively) which discharges onto an 18-inch rip rap lined, 6-foot flat bottom ditch prior to the stormwater ditch along West Wakefield Avenue. The overall length of Overflow #1 is 62 feet.

Overflow #2 is a 24-inch corrugated metal pipe (CMP) (inlet and discharge elevations of 316.75 feet and 307.0 feet) with an overall length of 979.94 feet. Overflow #2 discharges onto a 10-foot wide concrete spillway into the Process Waste Pond. See Appendix B – Historical Construction Drawings for details of the overflow structure and piping.

3.5 Instrumentation

The Fly Ash Pond was constructed with limited instrumentation. The flow measurement device on Overflow #1 is not in use. No additional flow or water level measurement instrumentation is currently installed for the Fly Ash Pond.

4.0 CHANGES IN CONSTRUCTION OR OPERATION

No changes to the construction to the Fly Ash Pond were identified in a review of facility documentation or through discussion with SPS personnel. As of October 19, 2015 disposal operations of CCR in the Fly Ash Pond were suspended. After the June 14, 2016 D.C. Circuit Court of Appeals ordered vacatur of the early closure provisions in §257.100, SPS resumed disposal operations of fly ash in to the Fly Ash Pond on a limited basis. Disposal operations are conducted by transporting fly ash in a dry state from SPS to the Fly Ash Pond by truck. Fly ash is disposed of in the Fly Ash Pond by pumping existing stormwater from within the Fly Ash Pond, mixing the stormwater with the dry fly ash, and sluicing the slurry into the Fly Ash Pond. No new process water from SPS is being added to the Fly Ash Pond by disposal operations.

5.0 RECORD OF INSTABILITY

A review of the available documents associated with the Fly Ash Pond at SPS did not reveal any record of instability for the Fly Ash Pond. Discussions with SPS personnel did not reveal any knowledge of instability for the Fly Ash Pond.

6.0 REFERENCES

This history of construction was developed based on a review of records at Sikeston Power Station. The records of review consisted of the following:

- Board of Municipal Utilities, Sikeston Power Station – Unit 1, Project 76-076-1, Contract 33 – Site Preparation 2 (included construction specifications) (See Appendix C – Historical Construction Specifications)
- Select Construction Drawings (See Appendix B – Historical Construction Drawings)
- Construction Coordination Meetings (August 1, 1978 – November 14, 1979)
- Weekly Construction Progress Reports (August 19, 1978, October 5, 1979)
- Final Inspection Correspondence (November 20, 1979 – March 6, 1980)
- Historical Photographs (June 30, 1978 – December 4, 1979)
- Geotechnology, Inc. 2011. “Global Stability Evaluation Fly Ash and Bottom Ash Ponds Sikeston Power Station Sikeston, Missouri

APPENDIX A

Figures

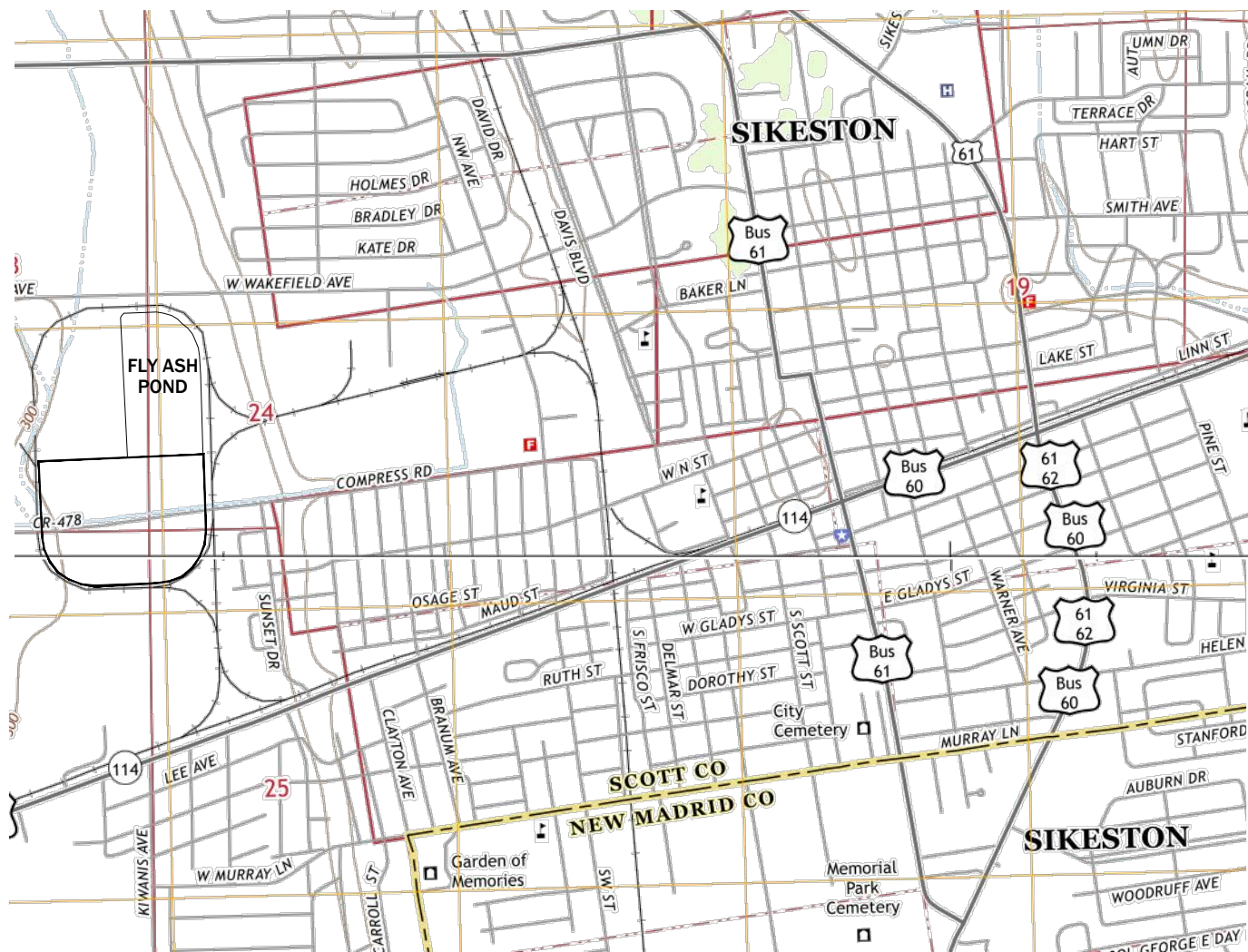

**USGS SIKESTON NORTH QUADRANGLE (2015)
 USGS SIKESTON SOUTH QUADRANGLE (2015)
 MISSOURI
 7.5 MINUTE SERIES**

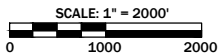

**HISTORY OF CONSTRUCTION
 FLY ASH POND
 SIKESTON POWER STATION**

GREDELL Engineering Resources, Inc.

ENVIRONMENTAL ENGINEERING LAND - AIR - WATER

1505 East High Street
 Jefferson City, Missouri

Telephone: (573) 659-9078
 Facsimile: (573) 659-9079

MO CORP. ENGINEERING LICENSE NO. E-2001001669-D

**FIGURE 1 - US GEOLOGICAL SURVEY
 TOPOGRAPHIC QUADRANGLE MAP**

DATE	SCALE	PROJECT NAME	REVISION
4/2018	AS NOTED	SIKESTON	
DRAWN CP	APPROVED JB	FILE NAME HISTORY OF CONST	SHEET # 1 OF 1



SCALE: 1" = 1500'
 0 750 1500

**HISTORY OF CONSTRUCTION
 FLY ASH POND
 SIKESTON POWER STATION**

GREDELL Engineering Resources, Inc.

ENVIRONMENTAL ENGINEERING LAND - AIR - WATER

1505 East High Street
 Jefferson City, Missouri

Telephone: (573) 659-9078
 Facsimile: (573) 659-9079

MO CORP. ENGINEERING LICENSE NO. E-2001001669-D

FIGURE 2 - AERIAL VIEW

DATE	SCALE	PROJECT NAME	REVISION
4/2018	AS NOTED	SIKESTON	
DRAWN CP	APPROVED JB	FILE NAME HISTORY OF CONST	SHEET # 1 OF 1

APPENDIX B

Historical Construction Drawings

SYSTEM OPERATING DESCRIPTION FOR PONDS

I. PURPOSE

The following is a discussion of the philosophy for disposing of the bottom ash, scrubber sludge and fly ash. The physical arrangements of the disposal piping are discussed in regard to the initial arrangement and future extensions to the systems. The arrangement of the ponds and associated overflow/blowdown lines are described. Discussions are also included for the Coal Pile Runoff Pond and the Process Waste Pond. A Process Flow Diagram is included for reference.

II. GENERAL

All ponds have a clay liner two feet thick (based on clay with a coefficient of permeability of 3.2×10^{-7} cm/sec). The thickness of two feet is selected as a minimum to provide a liner without pipes or chimneys from construction procedures. The coefficient of permeability of 3.3×10^{-7} cm/sec is required to limit seepage to $\frac{1}{4}$ -inch per day or less. ($\frac{1}{4}$ -inch per day or less percolation is a requirement of the State of Missouri.) The required 3.2×10^{-7} cm/sec is based on a pond water depth of 19 feet above a two foot thick clay layer. This will result in a design percolation rate of $\frac{1}{8}$ -inch per day or a factor of safety of 2.0.

The plant waste water is discharged from the Process Waste Pond into Drainage Ditch No. 4 of the Richland Drainage District. Periods of "zero discharge" will occur when Drainage Ditch No. 4 is at or near flood stage. During periods of zero discharge, the following waste water flows must not be allowed to enter the Process Waste Pond:

- 1) Bottom Ash Pond Overflow
- 2) Fly Ash Pond Overflow
- 3) Demineralizer Sump Pump Discharge

The result will be that the only flows entering Drainage Ditch No. 4 will be normal runoff flows. According to an agreement with the Richland Drainage District, a total waste water retainage of 14 days minimum must be provided. Approximately 30 days storage is available with the pond arrangement and operating levels described herein.

III. BOTTOM ASH SCRUBBER SLUDGE POND (hereinafter referred to as Bottom Ash Pond)

A. Characteristics

1. Characteristics of Bottom Ash

Bottom ash, when sluiced into the pond, forms a stable mound at the discharge point. As the mound extends out into the pond, additional piping and supports can be added to extend the discharge point farther out into the pond.

2. Characteristics of Scrubber Sludge Slurry

Past experience indicates that when scrubber sludge is discharged into the pond, it forms a nonstable mound which disperses around and away from the discharge point. The degree to which the sludge disperses depends on the density of the sludge. Fully oxidized sludge is least dense and when discharged into the pond may flow away from the discharge point up to 2,000 feet and may flow laterally from the discharge 500 feet to 750 feet.

3. Water Quality

In addition to the bottom ash sluice and the recycled scrubber sludge sluice, the Bottom Ash Pond receives the plant drains. The plant drain pH is expected to be approximately 7.0. Since the bottom ash is being sluiced with once-through cooling tower blowdown water, its pH is expected to be approximately 7.0 also. The scrubber sludge pH is expected to be between 6 and 6.5 with a chlorides content of 35,000 ppm. It is because of the high chlorides content that all wetted surfaces within the recycle system have been specified of nonferrous material.

B. Discharge Scheme

1. Bottom Ash

The bottom ash is discharged in the northwest corner of the pond. Refer to Figure No. 1. This discharge point will be extended in a southeasterly direction as the bottom ash accumulates. The discharge point may be extended up to 1,050 feet out into the

RECEIVED
JUL 31 1980

pr SIKESTON

pond with the present bottom ash sluicing pumps. Piping for future expansion has been furnished and stored on the jobsite for future use. It may be necessary to modify the bottom ash hydro ejectors as the discharge pipe is extended.

The volume of bottom ash is expected to be approximately 11 acre-feet per year

2. Scrubber Sludge

Two full capacity scrubber sludge lines are provided. The scrubber sludge lines run down the west Bottom Ash Pond dike to a point just south of the Compress Road Storm Runoff Culvert. The scrubber sludge will disperse away from the point of discharge. (See Figure 1.) If the scrubber sludge buildup dictates, the discharge point may be moved north or south along the dike.

The volume of scrubber sludge is expected to be approximately 55 acre-feet per year.

C. Pond Operation

Water will be recycled from the Recycle Structure to the scrubber sludge sluicing system. Water for bottom ash handling will be once-through from the circulating water system. Because of the one-cycle usage of this water, blowdown from the Bottom Ash Pond will be continuous. The blowdown will flow by gravity from the Blowdown Structure to the Process Waste Pond. The water level in the Bottom Ash Pond will be adjusted at the Blowdown Structure by installing stop logs and/or throttling a valve in the blowdown line.

The pond elevations are as follows:

a. Pond Bottom (Top of Clay Liner)	Elevation 302
b. Top of Dike	Elevation 322
c. Top of Water:	
Minimum	Elevation 317
Maximum for waste storage during no discharge	Elevation 321

The minimum top of water elevation is for settling performance, as the pond must act as a settling basin. The pond will be filled 19

RECEIVED
JUL 31 1980

feet deep with ash and sludge (El. 321). As solids accumulate in the pond, the minimum water level (El. 317) must be raised to provide a clear water return.

During periods of zero discharge, blowdown from the Bottom Ash Pond to the Process Waste Pond must be shut off. The valve in the blowdown line must be closed and a volume of water equivalent to the blowdown will be retained in the pond. If the pond water level should reach Elevation 321'-0" during periods of zero discharge, an overflow is provided from the Bottom Ash Pond into the Fly Ash Pond to provide additional storage capacity (see Figure 1).

Monthly grab samples should be obtained at the Blowdown Structure to monitor water quality.

IV. FLY ASH POND

A. Characteristics of Fly Ash

The fly ash is conveyed pneumatically from the silo to the pond and is discharged at a point 1.5 feet below the liquid level in the pond to prevent excessive dusting. When the fly ash is mixed with the water, it will mound up in a conical pile under the discharge point. The stability of the mound varies depending on the type of coal burned.

B. Discharge Scheme

The fly ash discharge piping extends out into the Fly Ash Pond on a floating pontoon system. The floating pontoon system consists of two identical floating sections, each 50 feet long and bolted together. Fifty (50) feet of flexible hose extends from the dike to the floating discharge system. The location of the discharge point is maintained by three tie-down ropes. The discharge point may be moved radially by adjusting the rope length and may be moved east-west by adding or removing a 50-foot section of the floating discharge system. The initial location of the floating discharge system is approximately 150 feet north of the southwest corner of the Fly Ash Pond. Additional supports have been provided and additional pipe stored on

on site so that the discharge point may be extended approximately 200 feet north of the initial location. As the pond fills, additional supports will need to be built and additional piping provided to move the discharge point farther north along the dike. The Pressure Fly Ash Blower has been sized so that the discharge point may be moved approximately 1300 feet north of the initial location.

C. Pond Operation

The normal pond water level should be maintained between Elevation 317'-0" and 319'-0". Maintaining the water level at 317'-0" will provide maximum storage during periods of zero discharge. The maximum pond water level during periods of zero discharge is Elevation 321'-0". When the water level is lowered it should be done slowly with the operators observing the overflow. If fly ash solids are observed being carried over to the Process Waste Pond, the overflow should be discontinued.

When the pond level is lowered, the fly ash may solidify, allowing a fixed piping system and related supports to be built out into the pond. The floating support system can then be moved farther east to allow for additional storage volume.

The Fly Ash Pond is provided with an overflow structure (See Figure 1) to control the water level in the pond. The water level will be controlled by stop logs and/or a sluice gate. The overflow water can be diverted either to the ditch (via Overflow No. 1) or to the Process Waste Pond (via Overflow No. 2). The Fly Ash Pond Overflow Structure is provided with a flow measuring nozzle and recording instrumentation for once/month, 24-hour total flow measurement.

V. COAL PILE RUNOFF POND

This pond is to provide for settling particles from runoff. The pond can possibly serve as a basin for chemical neutralization of the runoff if sufficient neutralization is not obtained with self-neutralization in the Process Waste Pond.

RECEIVED
JUL 31 1980

PR SIKESTON

The pond will be designed as a settling basin with a normal operating depth of 10 feet. Ten feet is the design operating depth as we presently know very little of the settling and carryover characteristics of the runoff waters and of the amount of dead storage required for settled solids. (AWWA Water Quality and Treatment, page 150, says use 8 to 16 feet operating depth for sedimentation basins.)

The Coal Pile Runoff Pond will have the following elevations:

- a. Pond Bottom (top of clay liner) Elevation 297.00
- b. Top of Water:
Elevation of spillway to Process Waste Pond Elevation 306.50

No flow measurement is required.

VI. PROCESS WASTE POND

The function of the Process Waste Pond is to provide a central collection mechanism for the plant waste streams that cannot be used for recycle water to the gas cleaning systems. Specifically, these are:

- a. Demineralizer Regeneration waste
- b. Coal Pile runoff
- c. Fly Ash Pond overflow (unless it is allowed to discharge directly to the ditch)
- d. Bottom Ash Pond blowdown

The pond serves as a neutralization and settling basin for the wastes prior to their discharge to Drainage Ditch No. 4. The basin is, therefore, designed as a settling basin with a 10 foot operating depth. This pond can possibly be operated at a depth of 8 feet. This would provide for additional storage during periods of zero discharge.

The Process Waste Pond will have the following elevations:

- a. Pond Bottom (top of clay liner) Elevation 297
- b. Top of Water:
Maximum for waste storage during no discharge (normal) Elevation 307
Minimum if operated at 8 feet deep Elevation 305

RECEIVED
JUL 31 1980
BIKESTON

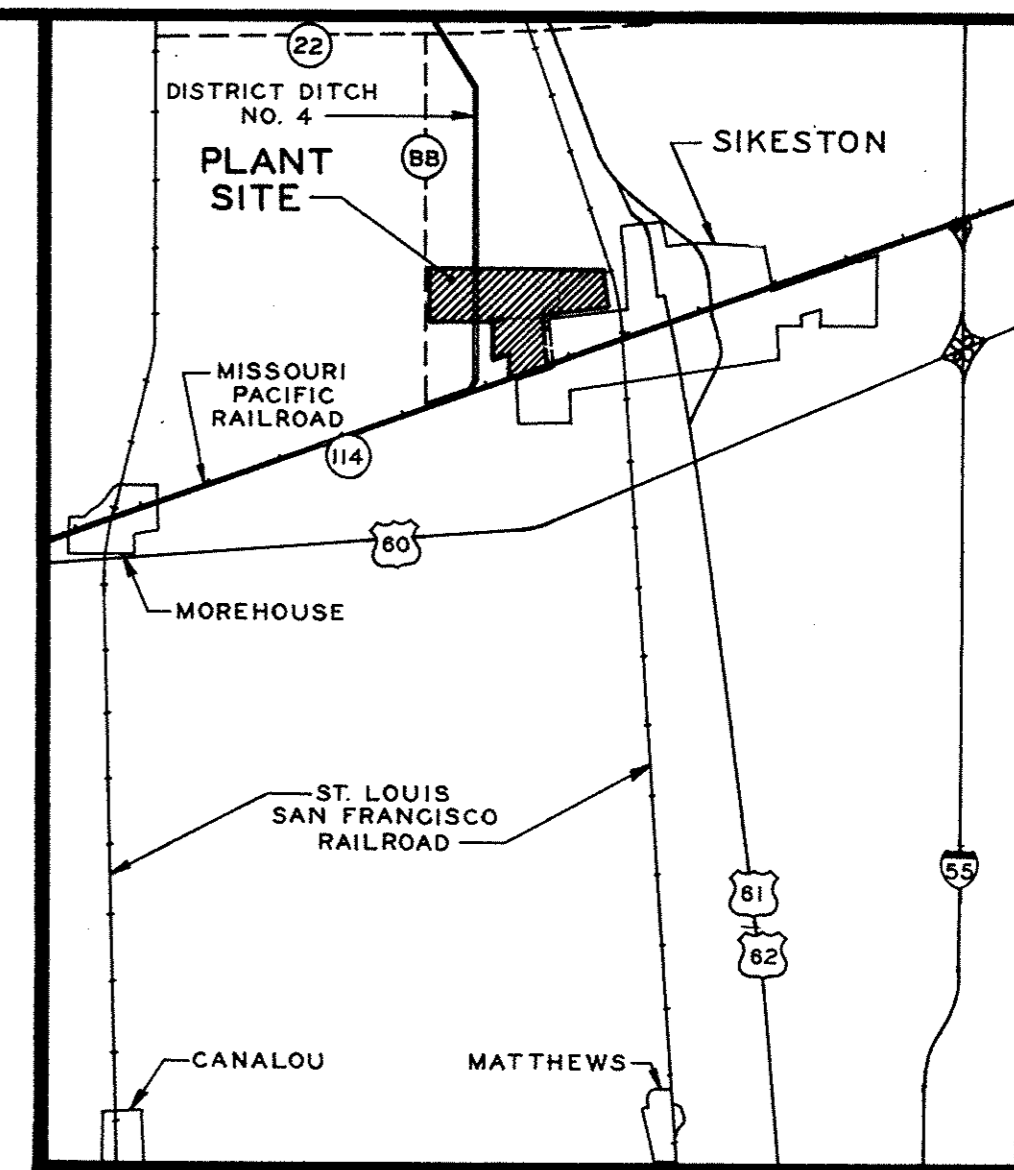

PROJECT 760761			
CONTRACT 33			
DATE JUNE 5, 1978			
DESIGNED KILE			
DETAILED BOBBITT			
CHECKED J.A.A.			
NO.	DATE	BY	REVISION
3-31-78		J.A.A.	ISSUED AS BID
6-14-82		R.G.P.	CONFORMED TO CONSTRUCTION RECORDS

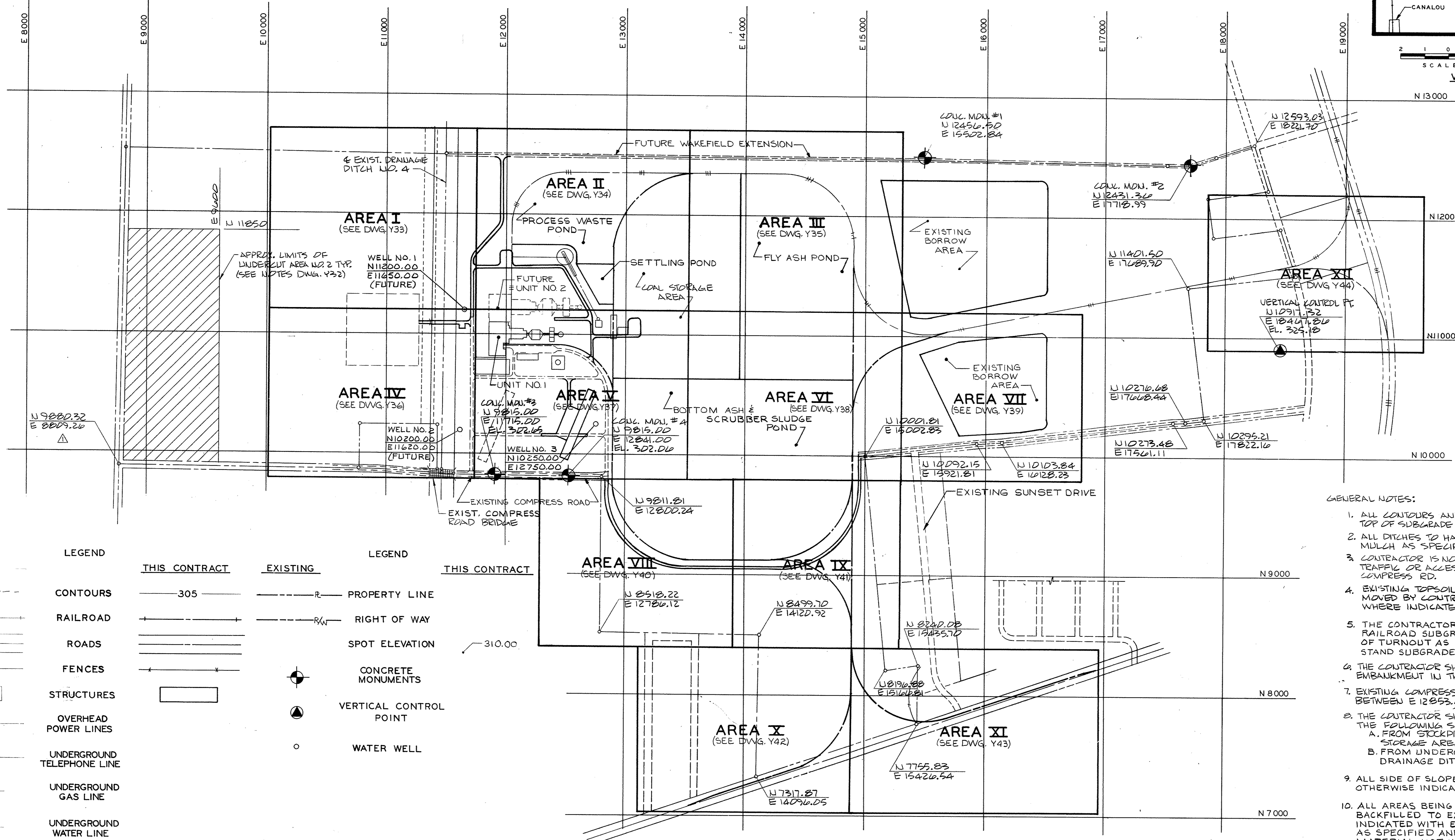

Scale in Centimeter

Scale in Inches

EXISTING	LEGEND	THIS CONTRACT	EXISTING	LEGEND	THIS CONTRACT
---305---	CONTOURS	---305---	---	PROPERTY LINE	---
====	RAILROAD	====	---	RIGHT OF WAY	---
====	ROADS	====	○	SPOT ELEVATION	310.00
X X	FENCES	X X	●	CONCRETE MONUMENTS	
□	STRUCTURES	□	▲	VERTICAL CONTROL POINT	
E	OVERHEAD POWER LINES		○	WATER WELL	
UT	UNDERGROUND TELEPHONE LINE				
UG	UNDERGROUND GAS LINE				
UW	UNDERGROUND WATER LINE				
---	TOP OF SLOPE	---			
---	TOE OF SLOPE	---			
---	FLOW INDICATOR	---			
⊘	RIP RAP	⊘			
⊘	CRUSHED ROCK	⊘			
---	CULVERT WITH END SECTIONS	---			
---	CULVERT WITHOUT END SECTIONS	---			
○	DROP INLET	○			
○	TREES AND SHRUBS	○			

- GENERAL NOTES:
1. ALL CONTOURS AND ELEVATIONS SHOWN ARE TOP OF SUBGRADE UNLESS OTHERWISE NOTED.
 2. ALL DITCHES TO HAVE 4" TOPSOIL SEED AND MULCH AS SPECIFIED. (SEE DETAIL DWG. Y 59)
 3. CONTRACTOR IS NOT TO INTERFERE WITH LOCAL TRAFFIC OR ACCESS TO PROPERTY ADJOINING CONGRESS RD.
 4. EXISTING TOPSOIL STOCKPILE SHALL BE MOVED BY CONTRACTOR AND PLACED WHERE INDICATED BY THE ENGINEER.
 5. THE CONTRACTOR SHALL CONSTRUCT RAILROAD SUBGRADE AT POINT OF SWITCH OF TURNOUT AS INDICATED ON SWITCH STAND SUBGRADE DETAIL, DWG. Y 59.
 6. THE CONTRACTOR SHALL CONSTRUCT ALL THE EMBANKMENT IN THE MO. PACIFIC RAILROAD SW.
 7. EXISTING COMPRESS RD. IS TO BE DEMOLISHED BETWEEN E 12855.00 AND E 14940.00.
 8. THE CONTRACTOR SHALL GET CLAY LINER FROM THE FOLLOWING SOURCES:
 - A. FROM STOCKPILE LOCATED AT THE COAL STORAGE AREA.
 - B. FROM UNDERCUT AREAS WEST OF DRAINAGE DITCH #4.
 9. ALL SIDE OF SLOPES ARE TO BE 2:1 UNLESS OTHERWISE INDICATED.
 10. ALL AREAS BEING UNDERCUT SHALL BE BACKFILLED TO EXISTING UNLESS OTHERWISE INDICATED WITH EMBANKMENT MATERIAL AS SPECIFIED AND EXCESS STRIPPING MATERIAL NOT USED IN TOPSOILING OPERATIONS. ALL BACKFILLED UNDERCUT AREAS SHALL BE GRADED TO DRAIN.

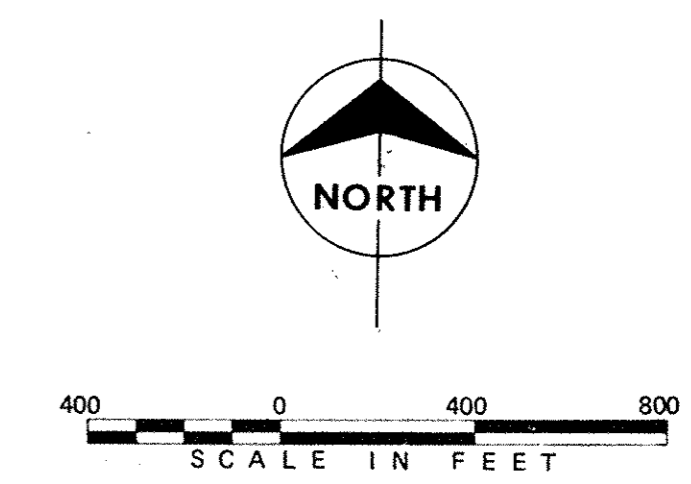

SITE PREPARATION 2
SITE PLAN AND VICINITY MAP

SIKESTON POWER STATION
UNIT NO. 1
BOARD OF MUNICIPAL UTILITIES

PHELPS HOGLAND & PHILLIPS
Engineering Company

BURNS & McDONNELL
Engineers-Architects-Consultants

DRAWING NO. SHEET OF SHEETS REV.
Y28 2

PROJECT 760761
 CONTRACT 33
 DATE JUNE 5, 1978
 DESIGNED KILLE
 DETAILED BOBBITT
 CHECKED JAA

NO.	DATE	BY	REVISION
8-31-78	JAA		ISSUED AS BID
5-24-79	FOBA		(L-4) REVISED ASH DIKE STATIONING AND COORDINATE
5-29-79	JAA		ISSUED
6-14-82	RGP		CONFORMED TO CONSTRUCTION RECORDS

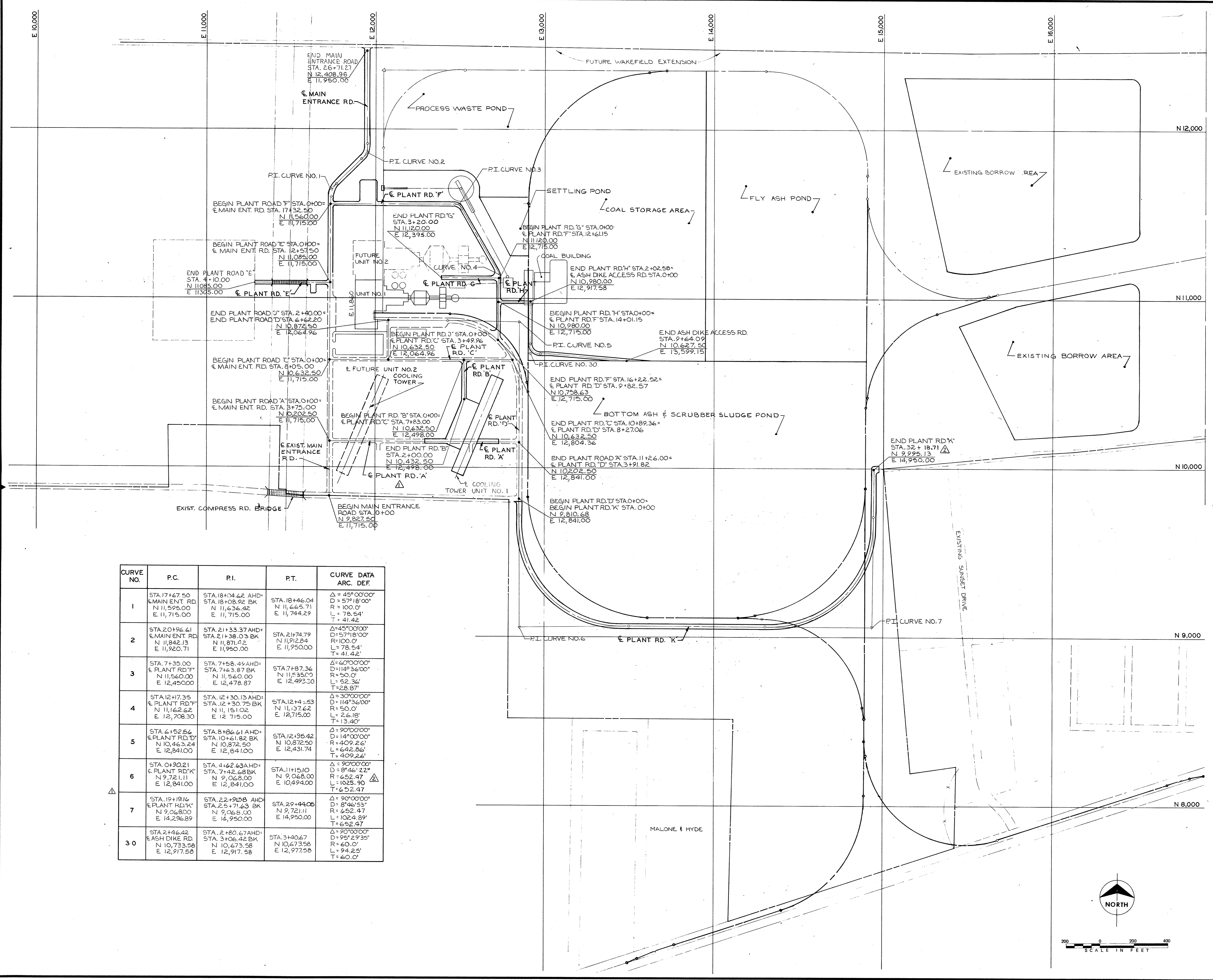

CURVE NO.	P.C.	P.I.	P.T.	CURVE DATA ARC. DEF.
1	STA. 17+67.50 E MAIN ENT. RD. N 11,595.00 E 11,715.00	STA. 18+04.62 AHD STA. 18+08.92 BK N 11,636.42 E 11,715.00	STA. 18+46.04 N 11,665.71 E 11,744.29	$\Delta = 45^{\circ}00'00''$ D = 57'18'00" R = 100.0' L = 78.54' T = 41.42'
2	STA. 20+96.41 E MAIN ENT. RD. N 11,842.13 E 11,920.71	STA. 21+33.37 AHD STA. 21+38.03 BK N 11,871.22 E 11,950.00	STA. 21+74.79 N 11,912.84 E 11,950.00	$\Delta = 45^{\circ}00'00''$ D = 57'18'00" R = 100.0' L = 78.54' T = 41.42'
3	STA. 7+35.00 E PLANT RD. F N 11,560.00 E 12,450.00	STA. 7+58.45 AHD STA. 7+63.87 BK N 11,560.00 E 12,478.87	STA. 7+87.36 N 11,535.00 E 12,492.00	$\Delta = 60^{\circ}00'00''$ D = 114'36'00" R = 50.0' L = 52.36' T = 28.87'
4	STA. 12+17.35 E PLANT RD. F N 11,162.62 E 12,708.30	STA. 12+30.13 AHD STA. 12+30.75 BK N 11,151.02 E 12,715.00	STA. 12+43.53 N 11,137.62 E 12,715.00	$\Delta = 30^{\circ}00'00''$ D = 114'36'00" R = 50.0' L = 26.18' T = 13.40'
5	STA. 6+52.64 E PLANT RD. D N 10,463.24 E 12,841.00	STA. 6+66.61 AHD STA. 10+61.82 BK N 10,872.50 E 12,841.00	STA. 12+96.42 N 10,872.50 E 12,431.74	$\Delta = 90^{\circ}00'00''$ D = 14'00'00" R = 409.26' L = 642.86' T = 409.26'
6	STA. 0+90.21 E PLANT RD. K N 9,721.11 E 12,841.00	STA. 4+62.63 AHD STA. 7+42.48 BK N 9,068.00 E 12,841.00	STA. 11+15.10 N 9,068.00 E 10,494.00	$\Delta = 90^{\circ}00'00''$ D = 8'46'22" R = 652.47' L = 1025.90' T = 652.47'
7	STA. 19+19.16 E PLANT RD. K N 9,068.00 E 14,296.89	STA. 22+91.08 AHD STA. 25+71.63 BK N 9,068.00 E 14,950.00	STA. 29+44.08 N 9,721.11 E 14,950.00	$\Delta = 90^{\circ}00'00''$ D = 8'46'22" R = 652.47' L = 1024.89' T = 652.47'
30	STA. 2+46.42 E ASH DIKE RD. N 10,733.58 E 12,917.58	STA. 2+80.67 AHD STA. 3+06.42 BK N 10,673.58 E 12,917.58	STA. 3+40.67 N 10,673.58 E 12,977.58	$\Delta = 90^{\circ}00'00''$ D = 95'29'35" R = 60.0' L = 94.25' T = 60.0'

Scale in Centimeter
 Scale in Inches

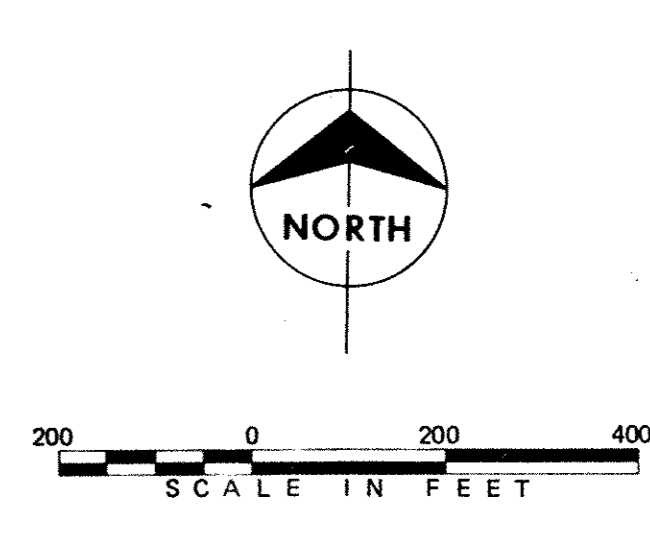

SITE PREPARATION 2
 ROAD GEOMETRY

**SIKESTON POWER STATION
 UNIT NO. 1**
 BOARD OF MUNICIPAL UTILITIES

PHELPS HOGLAND & PHILLIPS
 Engineering Company

BURNS & McDONNELL
 Engineers-Architects-Consultants

DRAWING NO. SHEET OF SHEETS REV.
 Y29 2

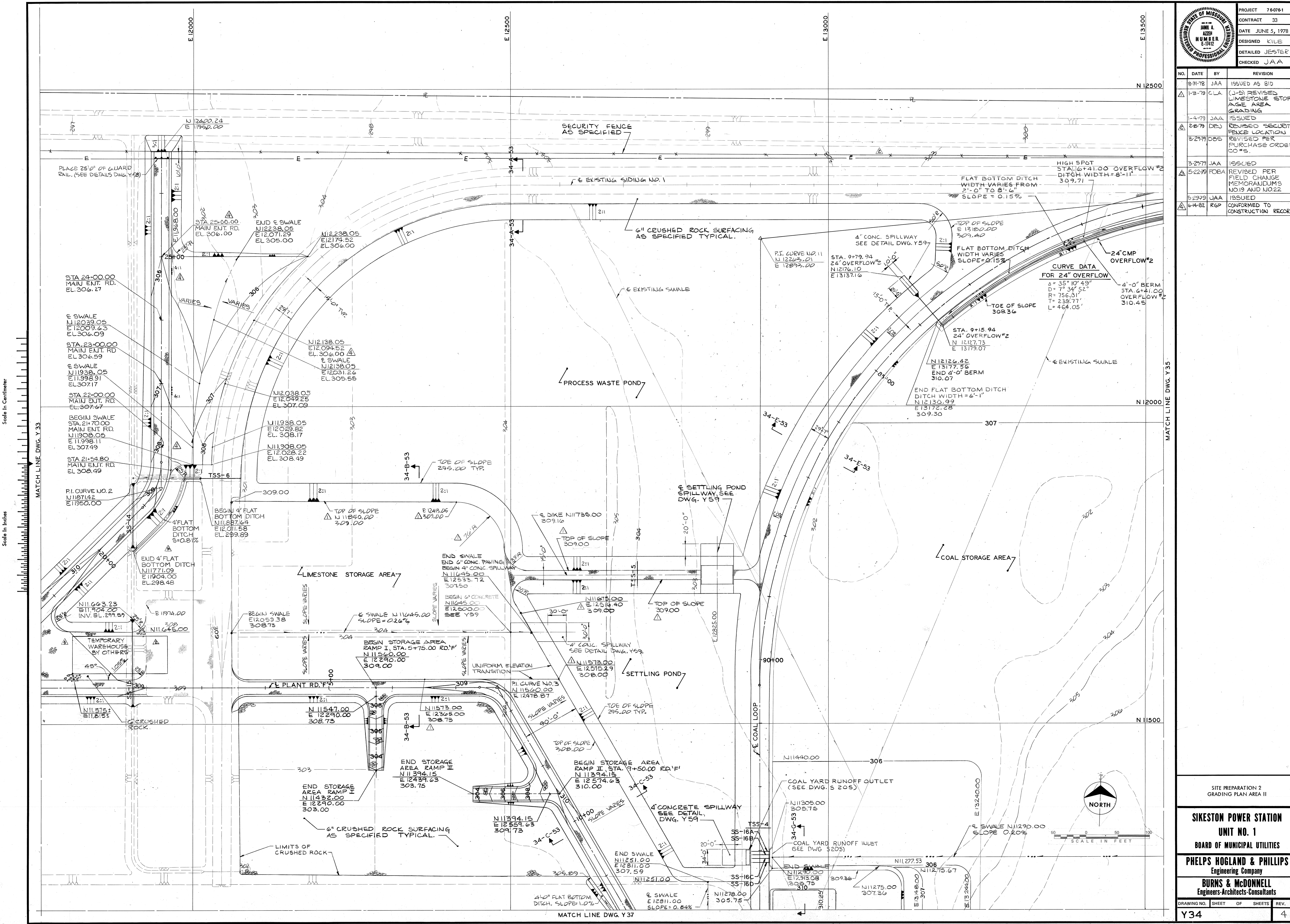

Scale in Centimeter

Scale in Inches

PROJECT 760761
 CONTRACT 33
 DATE JUNE 5, 1978
 DESIGNED KILE
 DETAILED JESTER
 CHECKED JAA

NO.	DATE	BY	REVISION
8-31-78	JAA		ISSUED AS BID
1-3-79	CLA		(J-S) REVISED LIMESTONE STORAGE AREA GRADING
1-4-79	JAA		ISSUED
2-8-79	DEJ		REVISED SECURITY FENCE LOCATION
3-27-79	DBS		REVISED PER PURCHASE ORDER CO#5
3-27-79	JAA		ISSUED
5-22-79	FOBA		REVISED PER FIELD CHANGE MEMORANDUMS MO19 AND MO22
5-29-79	JAA		ISSUED
6-14-82	RGP		CONFORMED TO CONSTRUCTION RECORDS

SITE PREPARATION 2
 GRADING PLAN AREA II

SIKESTON POWER STATION
 UNIT NO. 1
 BOARD OF MUNICIPAL UTILITIES

PHELPS HOGLAND & PHILLIPS
 Engineering Company

BURNS & McDONNELL
 Engineers-Architects-Consultants

DRAWING NO. SHEET OF SHEETS REV.
 Y34 4

NO.	DATE	BY	REVISION
8-31-78	JAA	JAA	ISSUED AS BID
2-27-79	DEJ	DEJ	REVISED SECURITY FENCE LOCATION
3-28-79	DBS	DBS	ADDED COAL YARD FILL STOCKPILE AREA, & LIMITS
3-29-79	JAA	JAA	ISSUED
6-14-82	RGP	RGP	CONFORMED TO CONSTRUCTION RECORDS

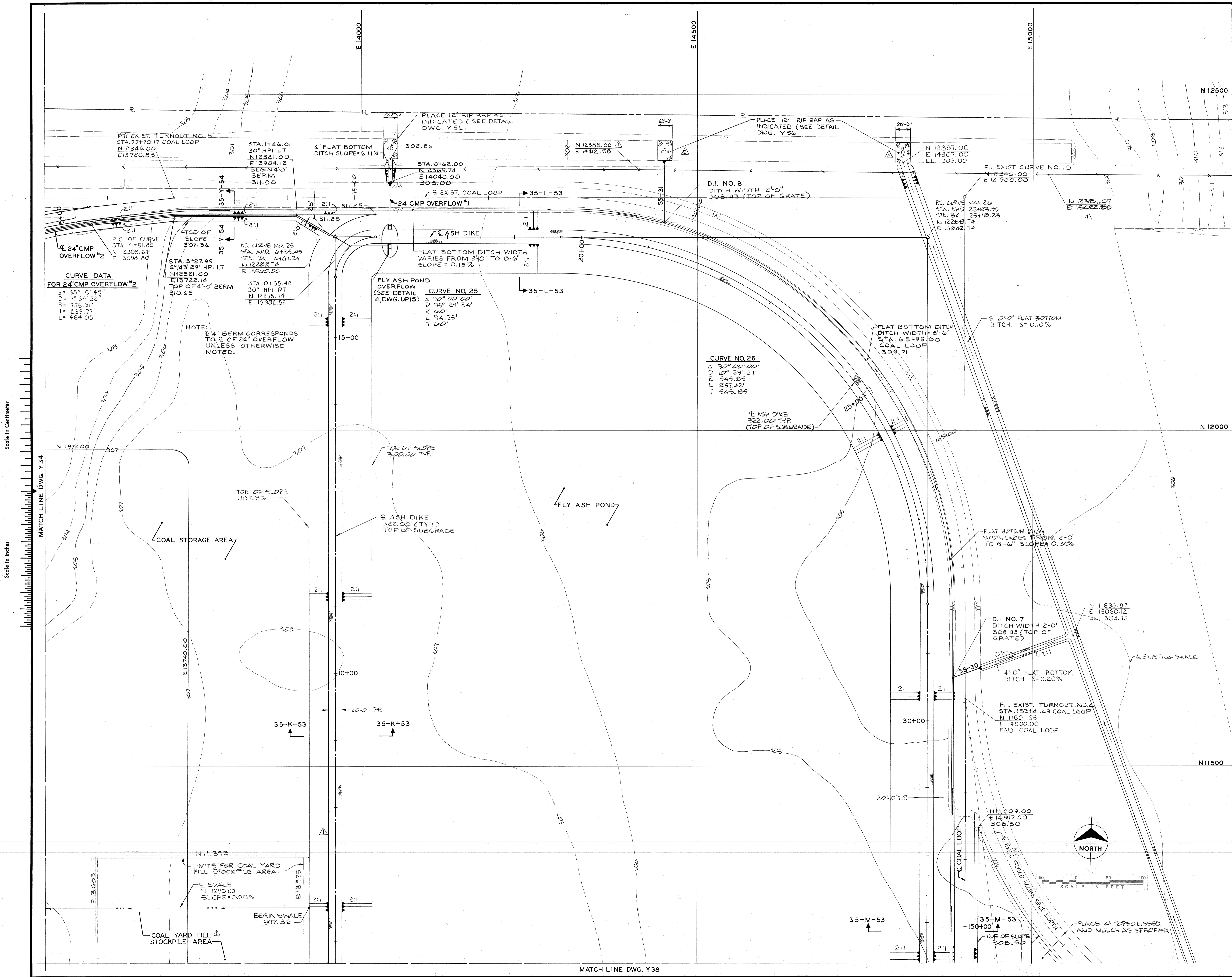

Scale in Centimeter
 Scale in Inches

SITE PREPARATION 2
 GRADING PLAN AREA III

SIKESTON POWER STATION
UNIT NO. 1
 BOARD OF MUNICIPAL UTILITIES
PHELPS HOGLAND & PHILLIPS
 Engineering Company
BURNS & McDONNELL
 Engineers-Architects-Consultants

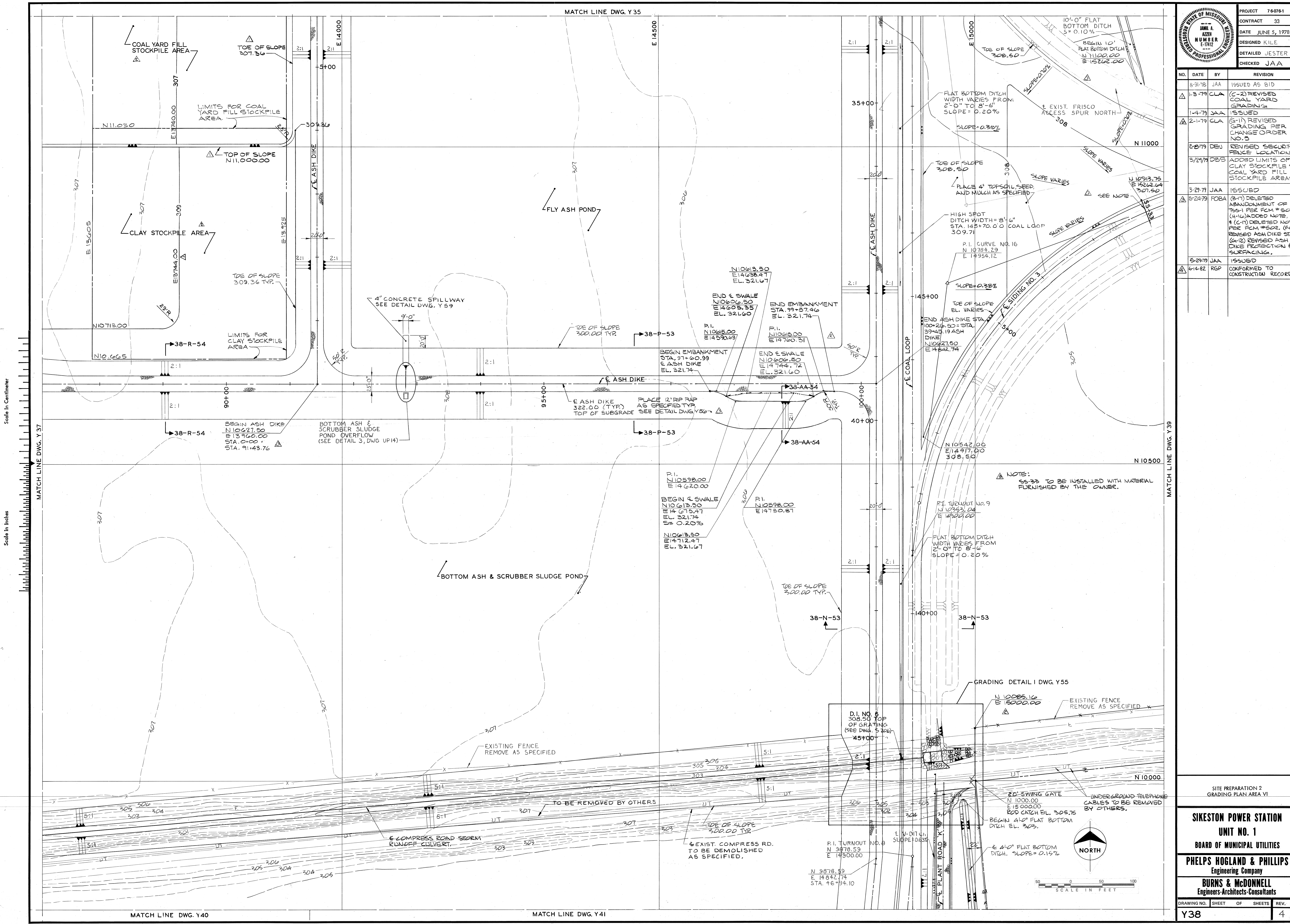

Scale in Centimeter

Scale in Inches

MATCH LINE DWG. Y 35

MATCH LINE DWG. Y 37

MATCH LINE DWG. Y 39

MATCH LINE DWG. Y 40

MATCH LINE DWG. Y 41

		PROJECT 76076-1 CONTRACT 33 DATE JUNE 5, 1978 DESIGNED JIA CHECKED JAA	
NO.	DATE	BY	REVISION
	8-31-78	JAA	ISSUED AS BID
Δ	1-3-79	CLA	(C-2) REVISED COAL YARD GRADING
Δ	1-4-79	JAA	ISSUED
Δ	2-1-79	CLA	(G-1) REVISED GRADING PER CHANGE ORDER NO. 5
	2-28-79	DEJ	REVISED SECURITY FENCE LOCATION
	3/29/79	DBS	ADDED LIMITS OF CLAY STOCKPILE & COAL YARD FILL STOCKPILE AREAS.
	3-29-79	JAA	ISSUED
Δ	5-24-79	FOBA	(B-7) DELETED ABANDONMENT OF TSS-1 PER FCM #502. (H-1) ADDED NOTE # (C-1) DELETED NOTE PER FCM #502. (F-8) REVISED ASH DIKE STA. (G-12) REVISED ASH DIKE PROTECTION & SURFACING.
	6-29-79	JAA	ISSUED
Δ	6-14-82	REP	CONFORMED TO CONSTRUCTION RECORDS

SITE PREPARATION 2
GRADING PLAN AREA VI

SIKESTON POWER STATION
UNIT NO. 1
BOARD OF MUNICIPAL UTILITIES

PHELPS HOGLAND & PHILLIPS
Engineering Company

BURNS & McDONNELL
Engineers-Architects-Consultants

DRAWING NO. SHEET OF SHEETS REV.
Y38 4

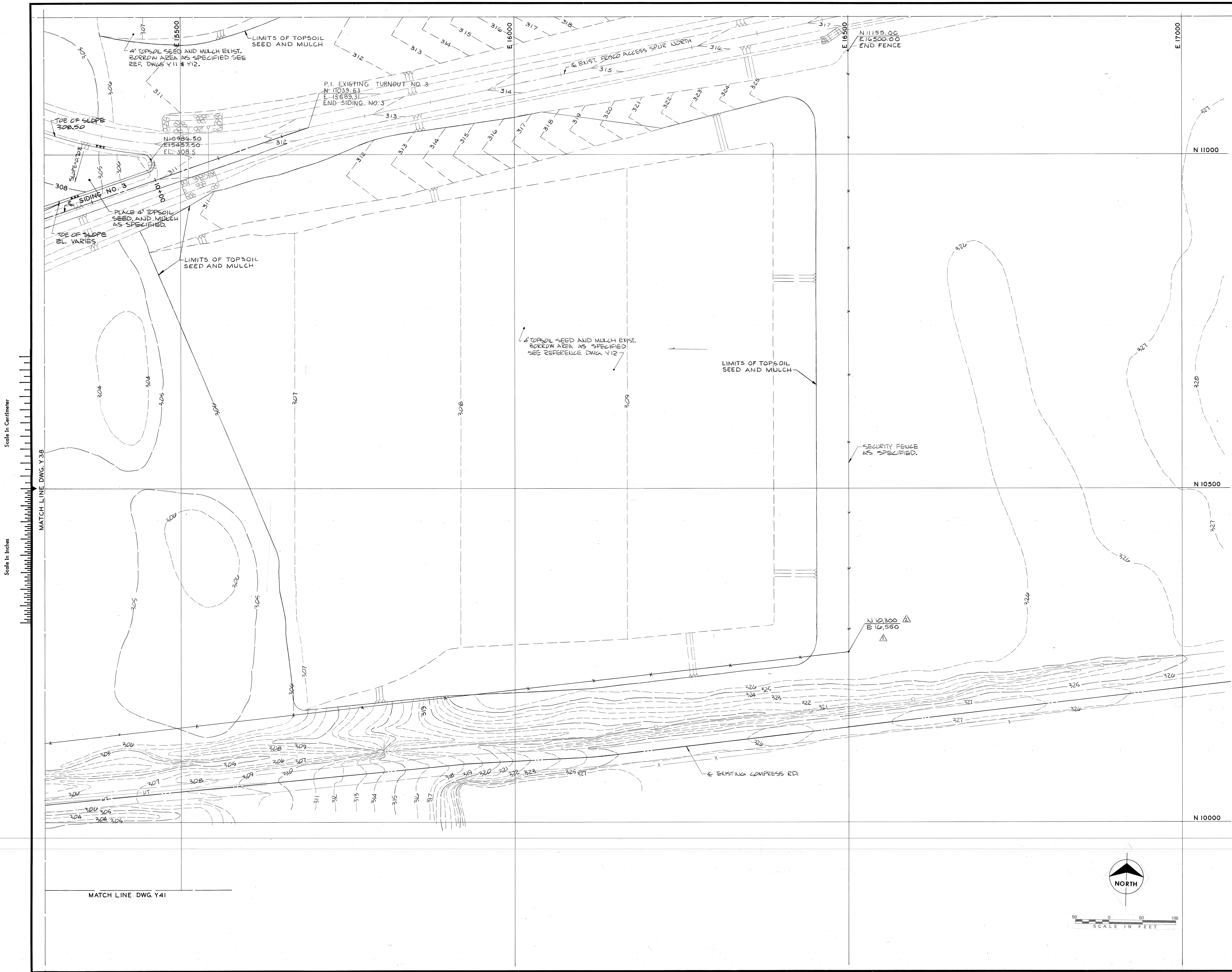

Scale in Centimeter

Scale in Inches

MATCH LINE DWG. Y 38

MATCH LINE DWG. Y 41

PROJECT 76-0761
 CONTRACT 33
 DATE JUNE 5, 1978
 DESIGNED KILE
 DETAILED WILKORD
 CHECKED JAA

NO.	DATE	BY	REVISION
8-31-78	JAA		BID AS ISSUED
2-7-79	DEJ		REVISED SECURITY FENCE LOCATION
3-27-79	JAA		ISSUED
6-14-82	RGP		CONFORMED TO CONSTRUCTION RECORDS

SITE PREPARATION 2
 GRADING PLAN AREA VII

SIKESTON POWER STATION
 UNIT NO. 1
 BOARD OF MUNICIPAL UTILITIES

PHELPS HOGLAND & PHILLIPS
 Engineering Company

BURNS & McDONNELL
 Engineers-Architects-Consultants

DRAWING NO.	SHEET	OF	SHEETS	REV.
Y39				2

PROJECT 760761
 CONTRACT 33
 DATE JUNE 5, 1978
 DESIGNED KILE
 DETAILED JESTER
 CHECKED JAA

NO.	DATE	BY	REVISION
8-31-78	JAA		ISSUED AS BID
1-3-79	CLA		(B-E) REVISED ELEVATIONS AND SLOPES, SECTION 34-B-53 (F-1) REVISED GRADING SECTION 34-G-53
1-4-79	JAA		ISSUED
5-29-79	FOBA		(F-2) DELETED SECTION 34-D-53
6-28-79	JAA		ISSUED
6-14-82	RGP		CONFORMED TO CONSTRUCTION RECORDS

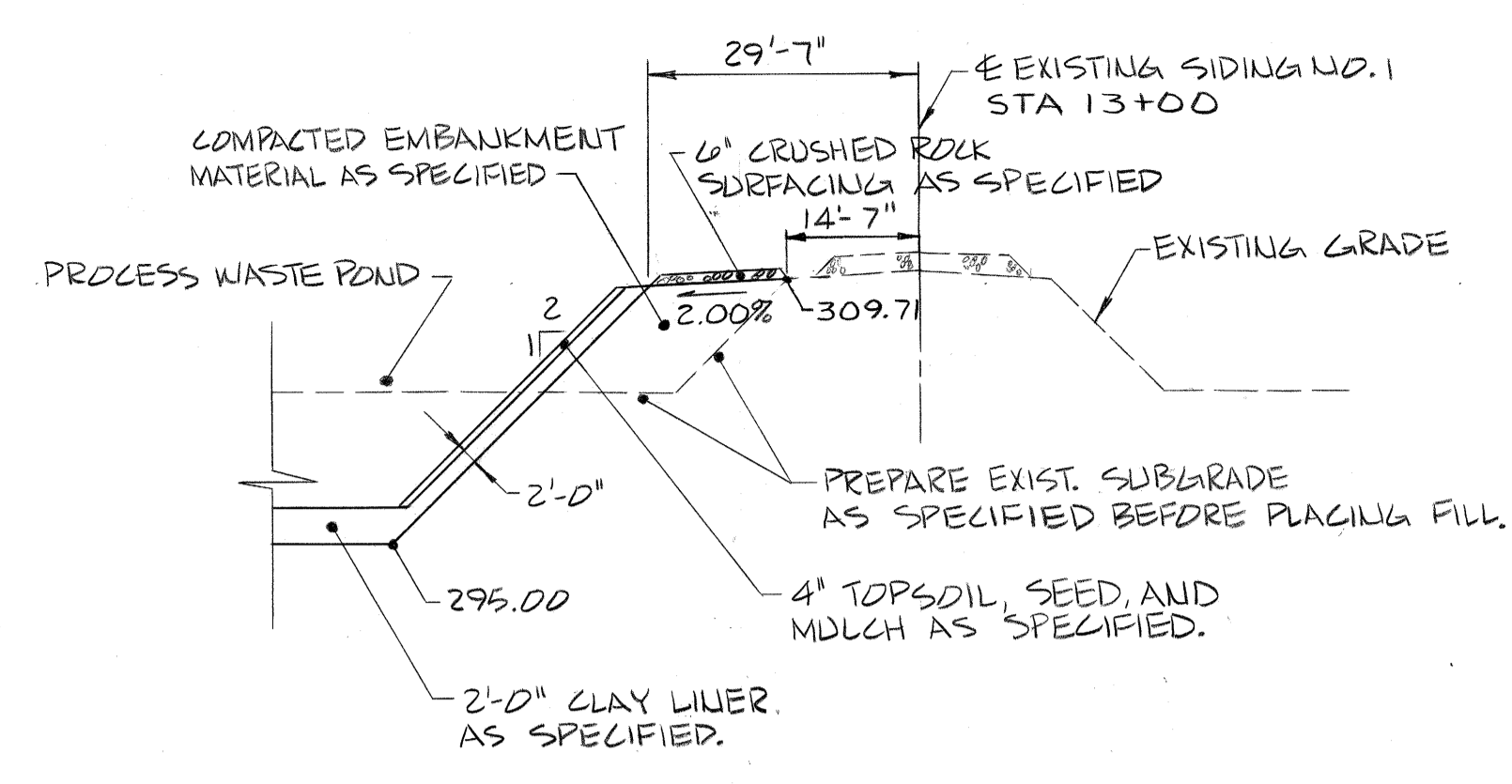

SECTION 34-A-53
NOT TO SCALE

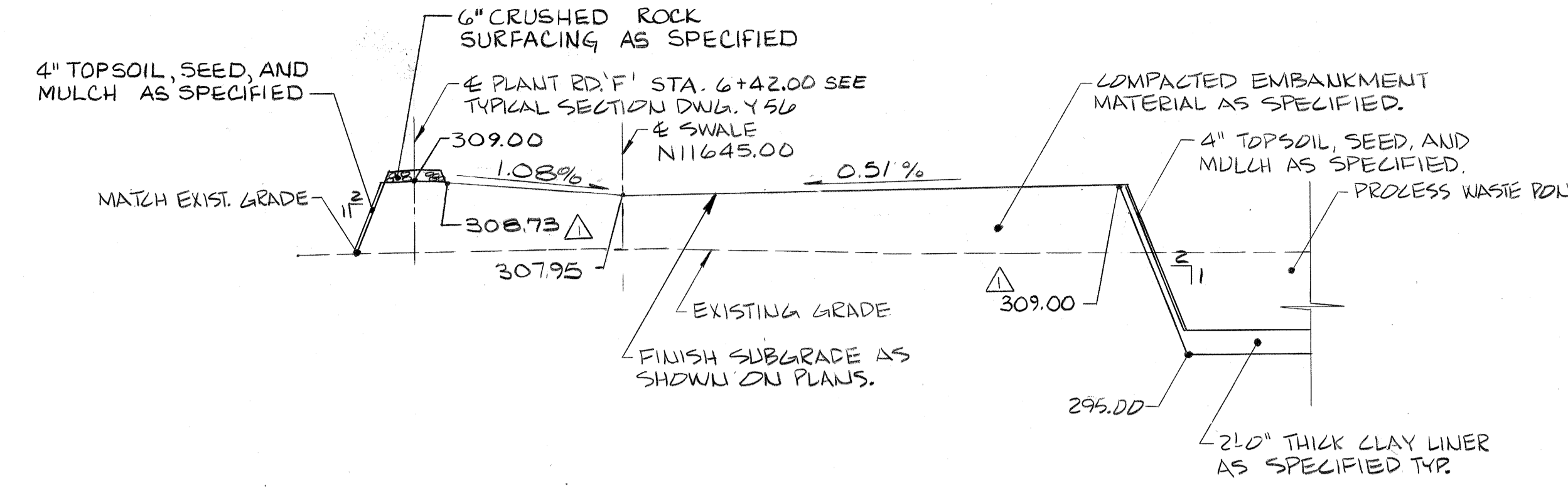

SECTION 34-B-53
NOT TO SCALE

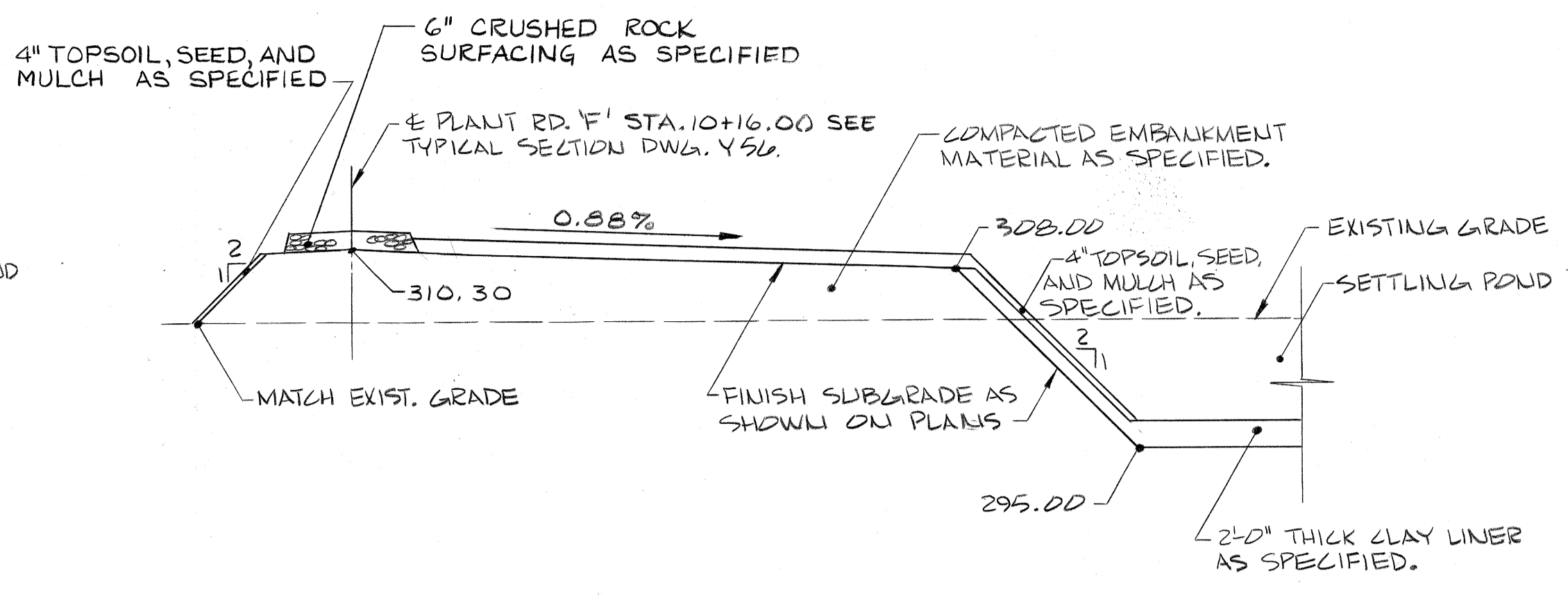

SECTION 34-C-53
NOT TO SCALE

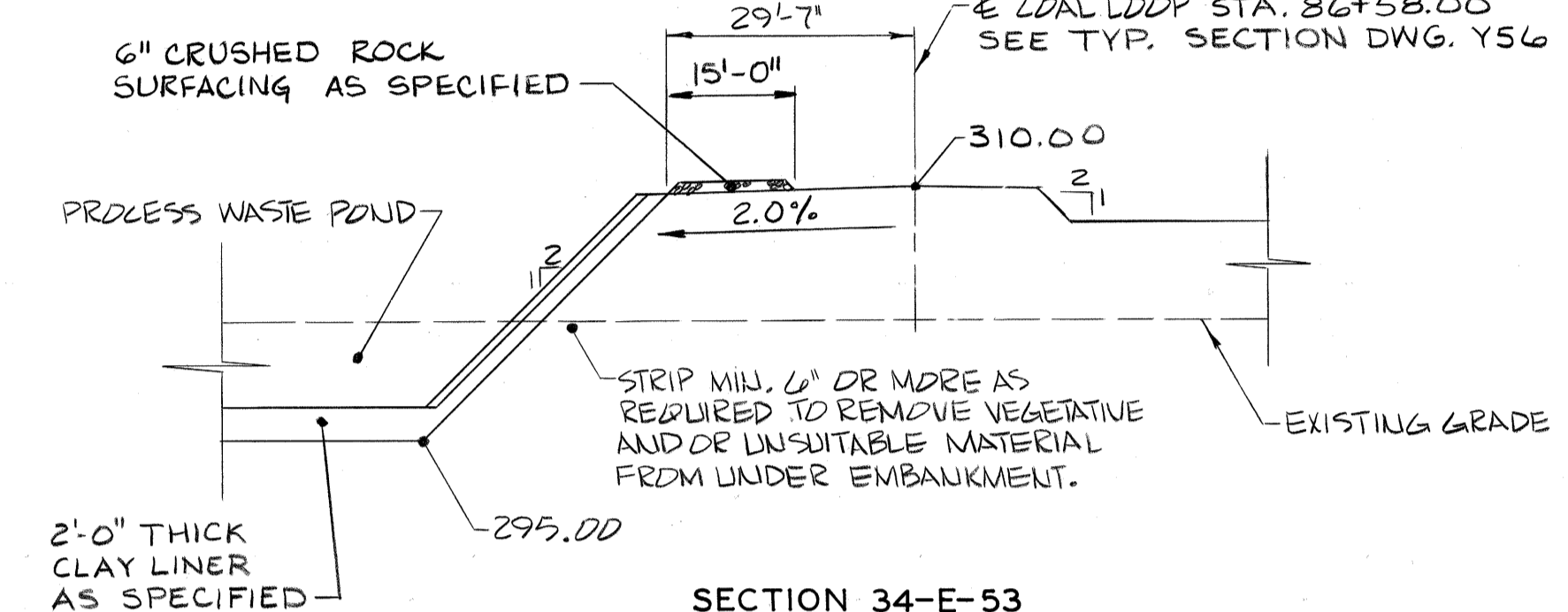

SECTION 34-E-53
NOT TO SCALE

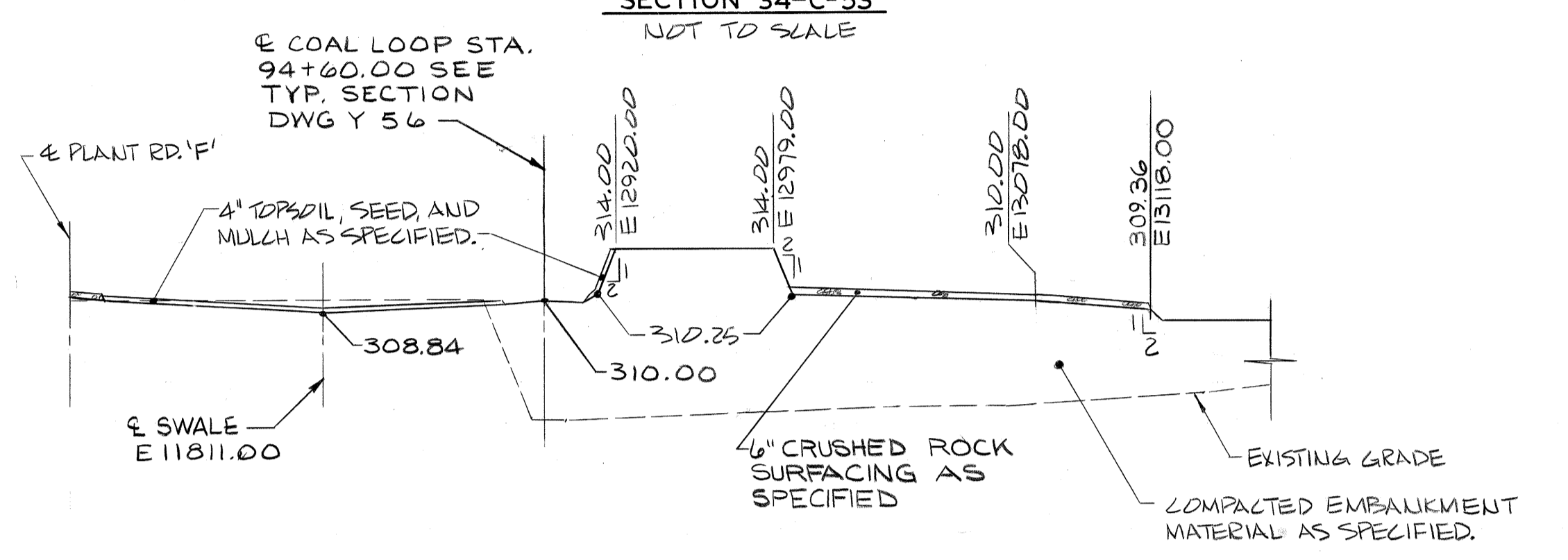

SECTION 37-F-53
NOT TO SCALE

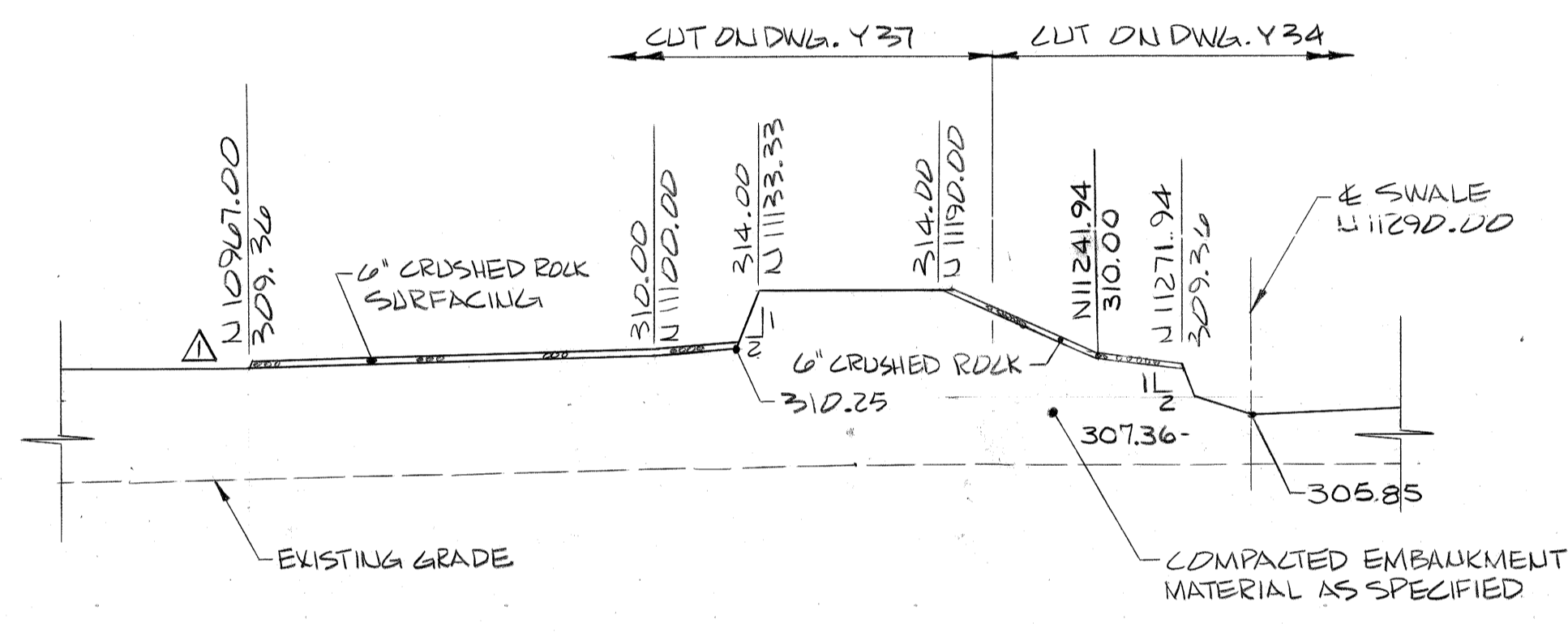

SECTION 34-G-53
NOT TO SCALE

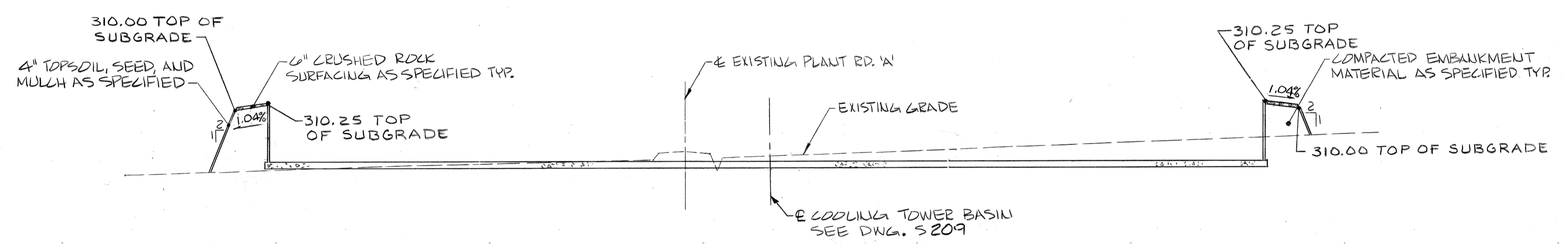

SECTION 37-H-53
NOT TO SCALE

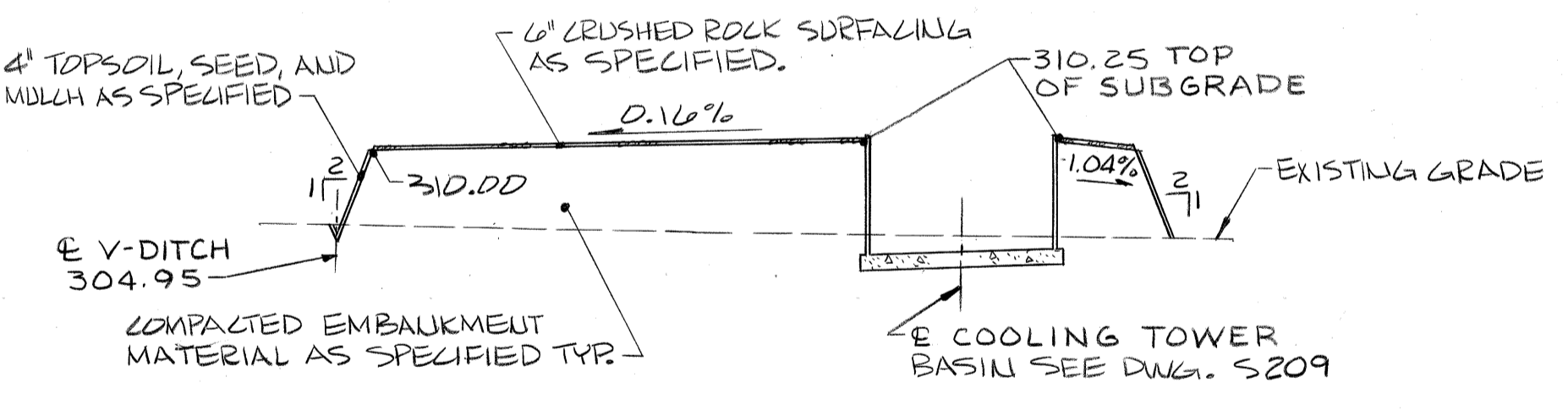

SECTION 37-J-53
NOT TO SCALE

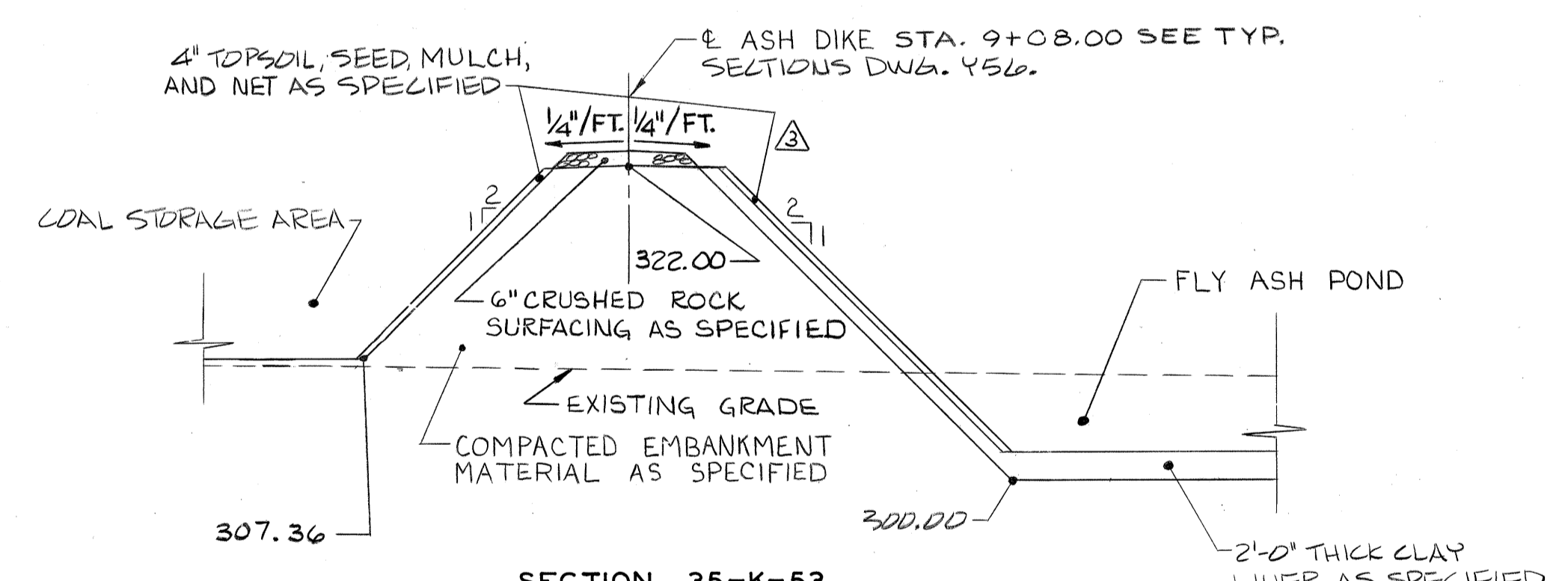

SECTION 35-K-53
NOT TO SCALE

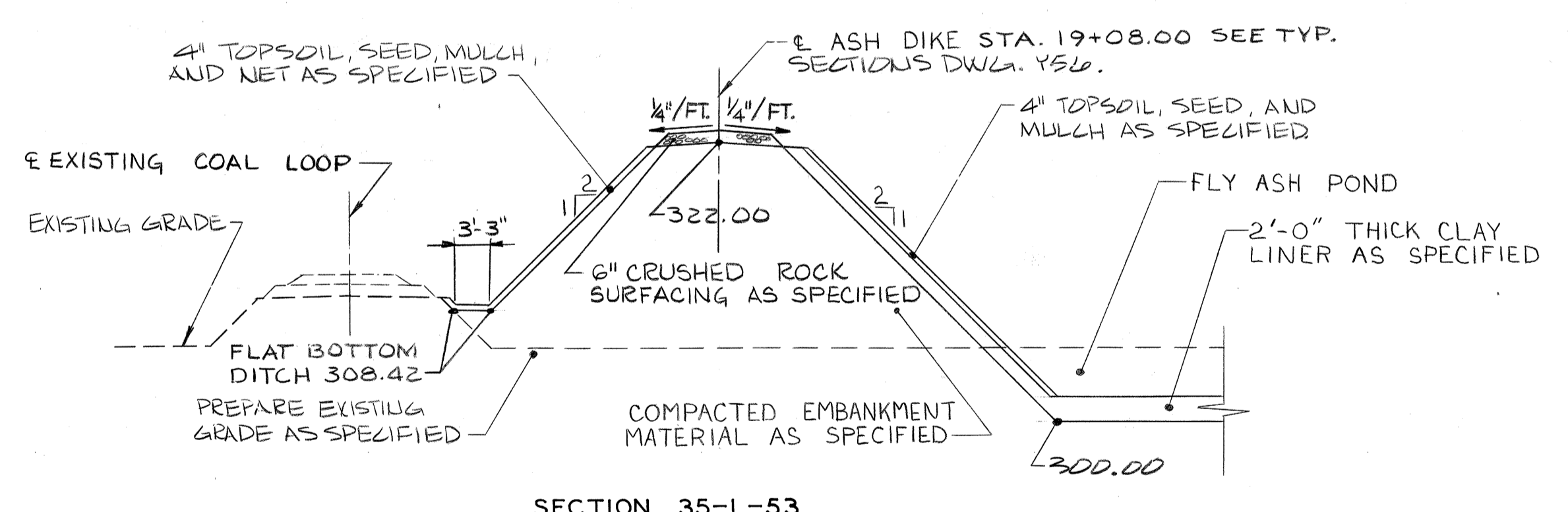

SECTION 35-L-53
NOT TO SCALE

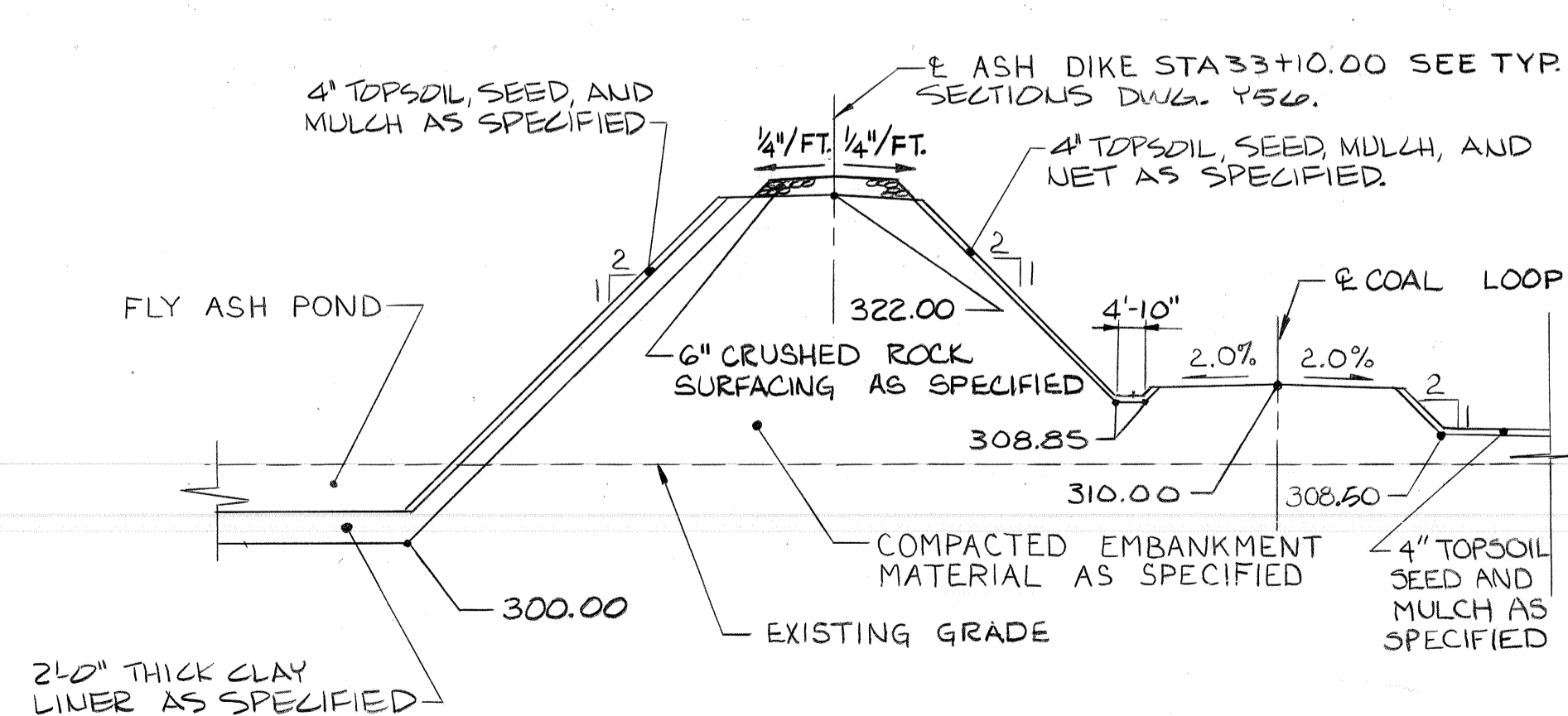

SECTION 35-M-53
NOT TO SCALE

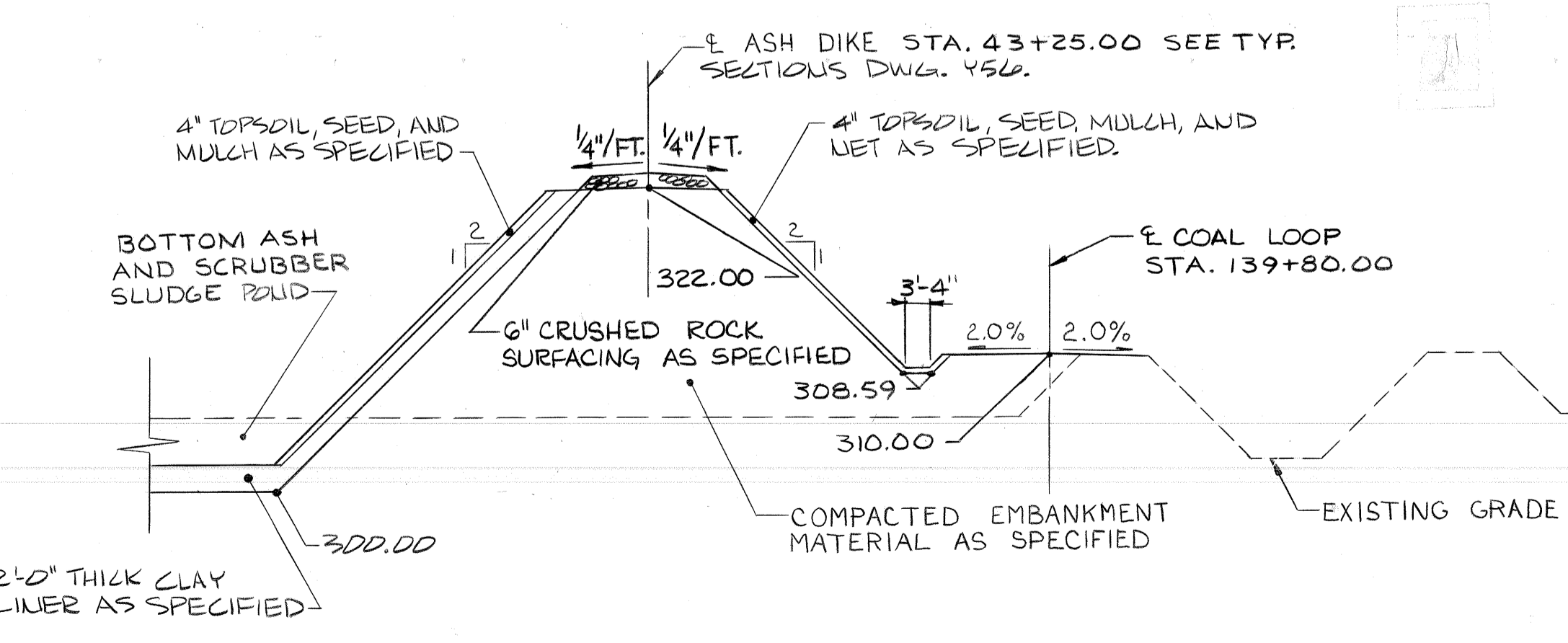

SECTION 38-N-53
NOT TO SCALE

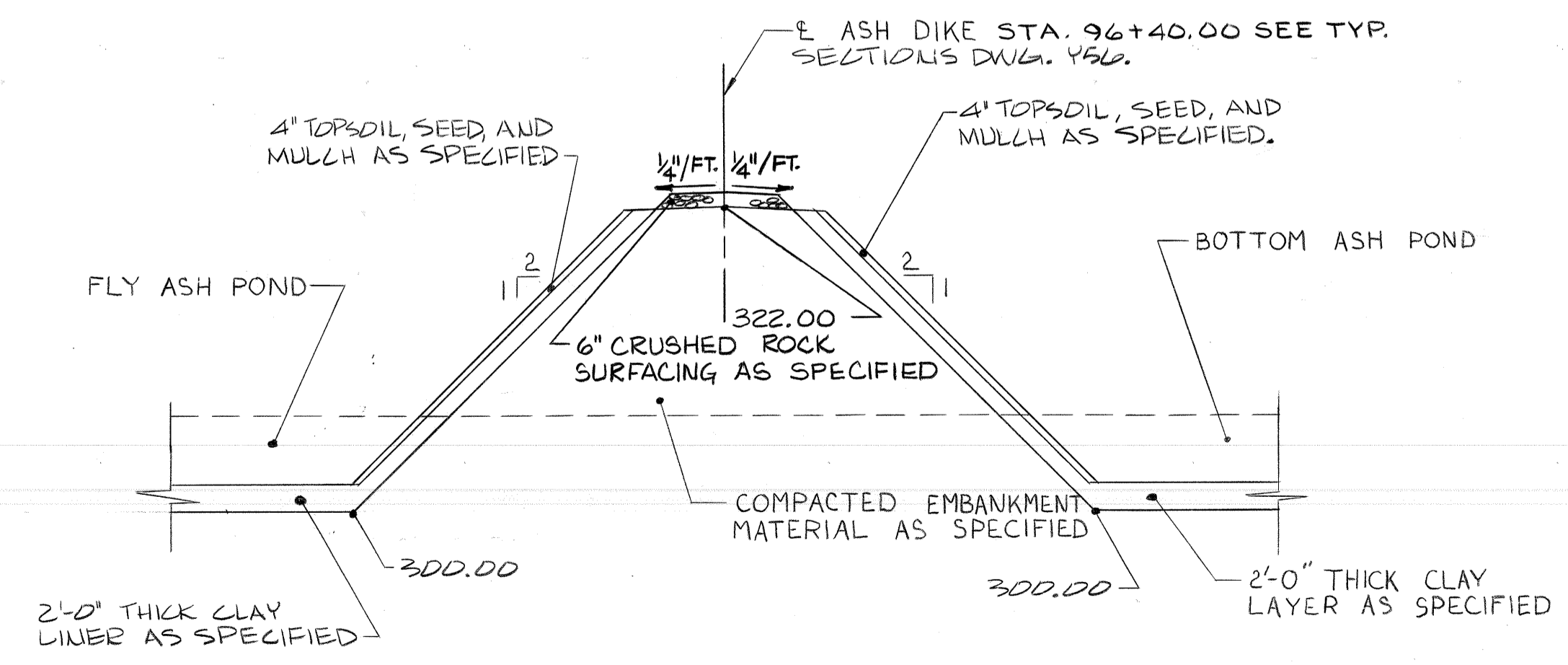

SECTION 38-P-53
NOT TO SCALE

Scale in Centimeter

Scale in inches

SITE PREPARATION 2
 GRADING SECTIONS 1

SIKESTON POWER STATION
 UNIT NO. 1
 BOARD OF MUNICIPAL UTILITIES

PHELPS HOGLAND & PHILLIPS
 Engineering Company

BURNS & McDONNELL
 Engineers-Architects-Consultants

DRAWING NO. SHEET OF SHEETS REV.
Y53 3

PROJECT 760761
 CONTRACT 33
 DATE JUNE 5, 1978
 DESIGNED KILE
 CHECKED JAA

NO.	DATE	BY	REVISION
	8-31-78	JAA	ISSUED AS BID
Δ	1-31-79	CLA	(B-1) REVISED GRADING SECTION 38-R-54, (E-14) REVISED GRADING SECTION 37-X-54.
	1-4-79	JAA	ISSUED
Δ	1-31-79	CLA	(H-10) ADDED SECTION 38-AA-54 PER CHANGE ORDER NO. 5
	3-29-79	JAA	ISSUED
Δ	5-26-79	FOBA	(E-8) CORRECTED STA. REFERENCE TO RD. 'K' & REVISED SIDE-SLOPE ON THE N. SIDE OF RD. 'K'. (E-11) REVISED EL. ON SECTION 40-W-54. (E-12) DELETED CRUSHED ROCK SURFACE FROM SECTION 38-AA-54
	5-29-79	JAA	ISSUED
Δ	6-14-82	RGP	CONFORMED TO CONSTRUCTION RECORDS.

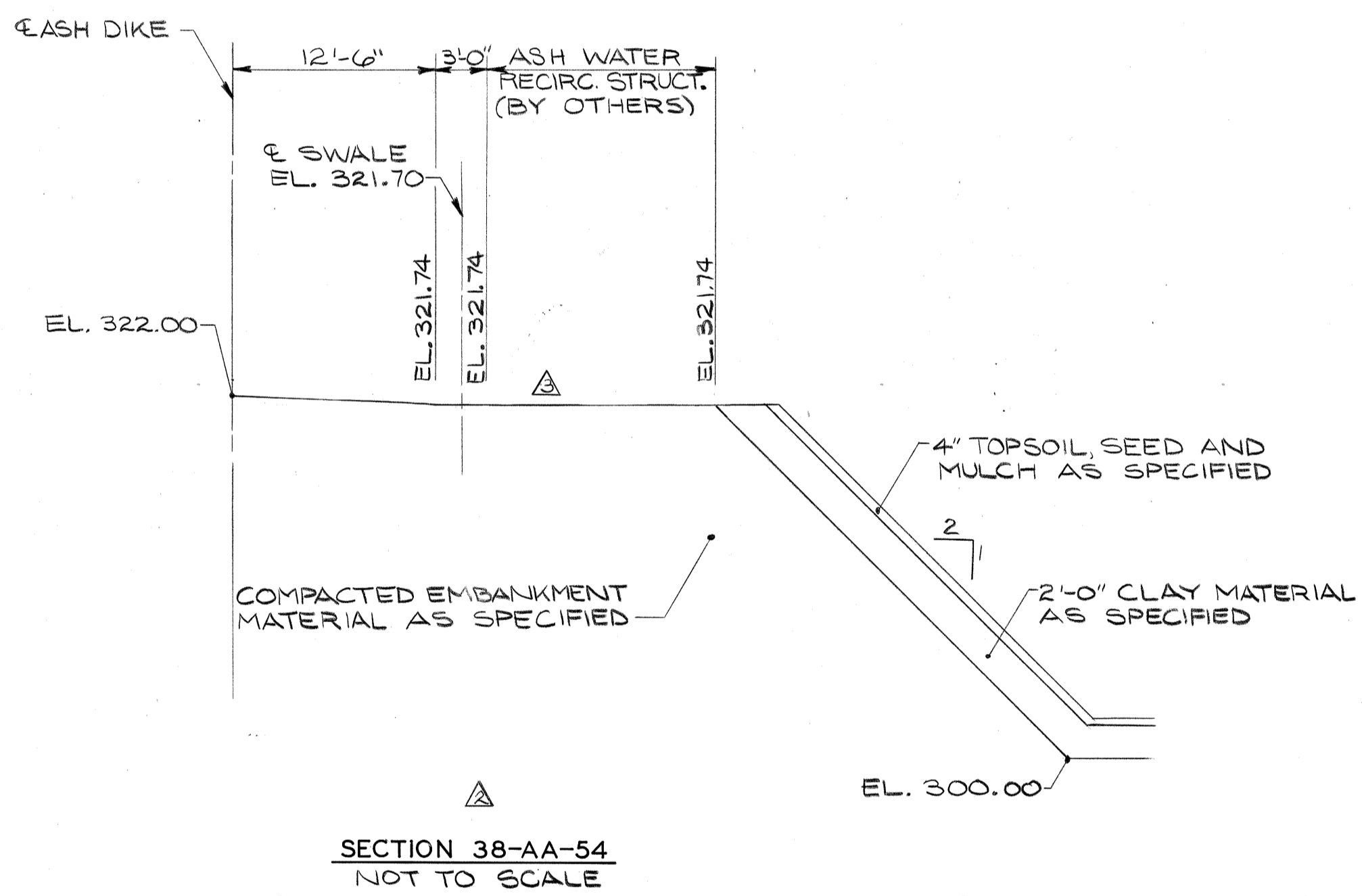
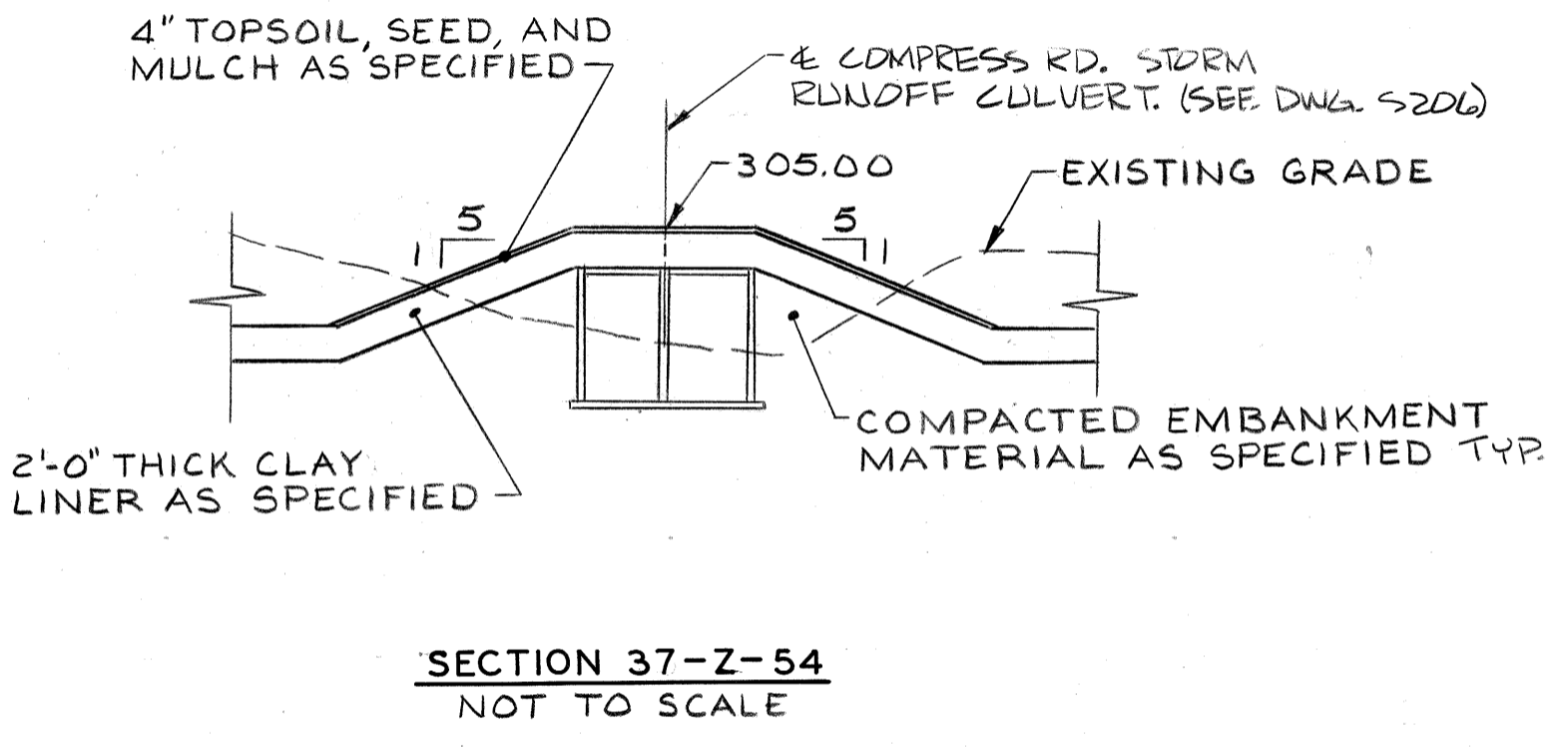
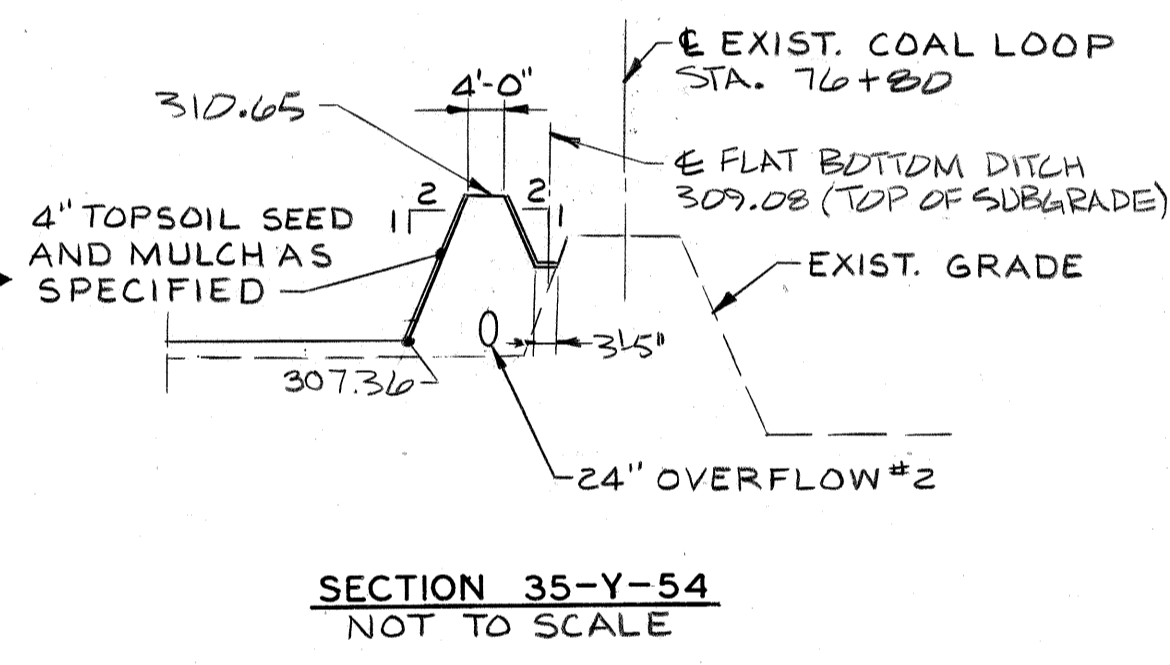
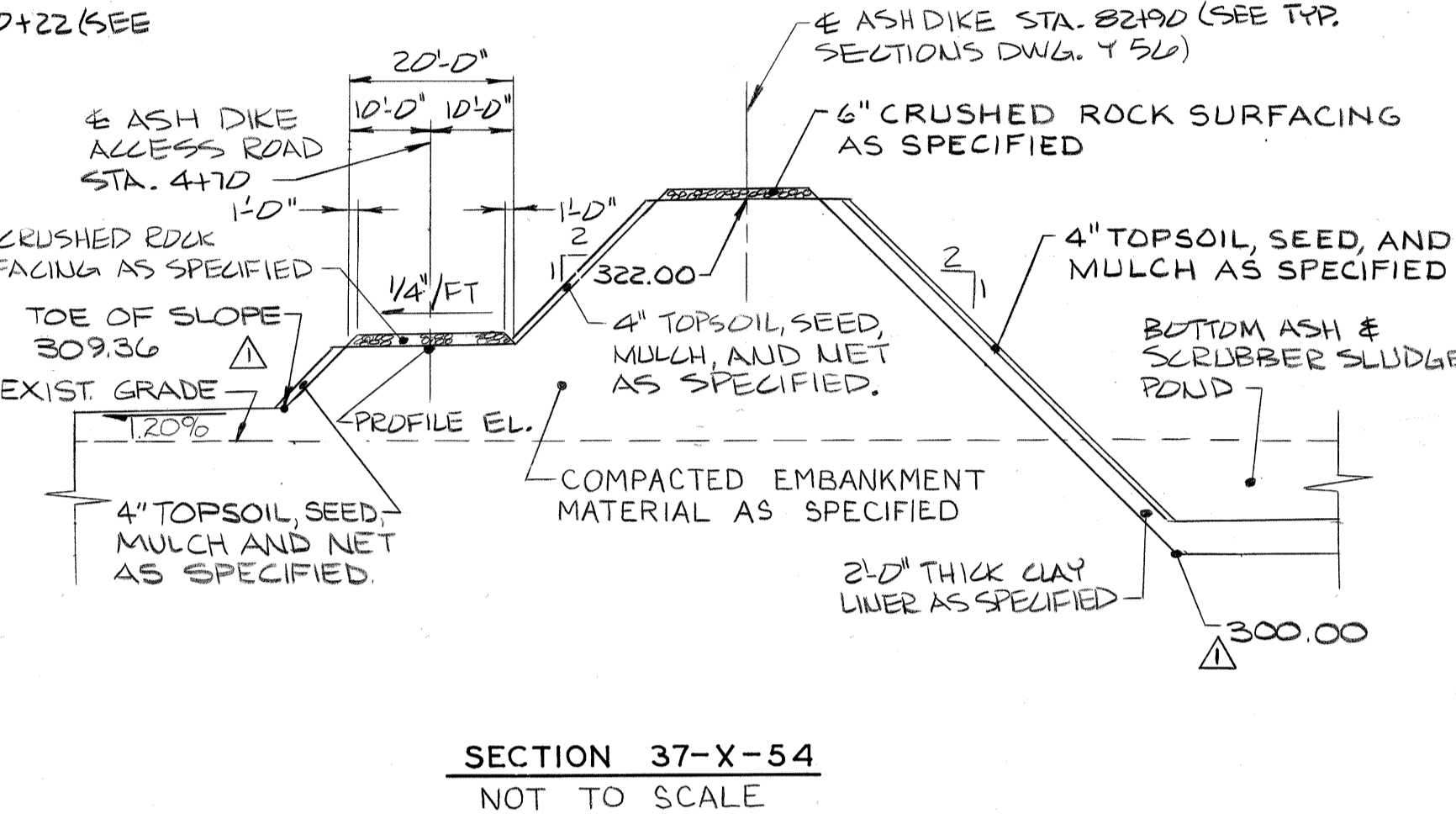
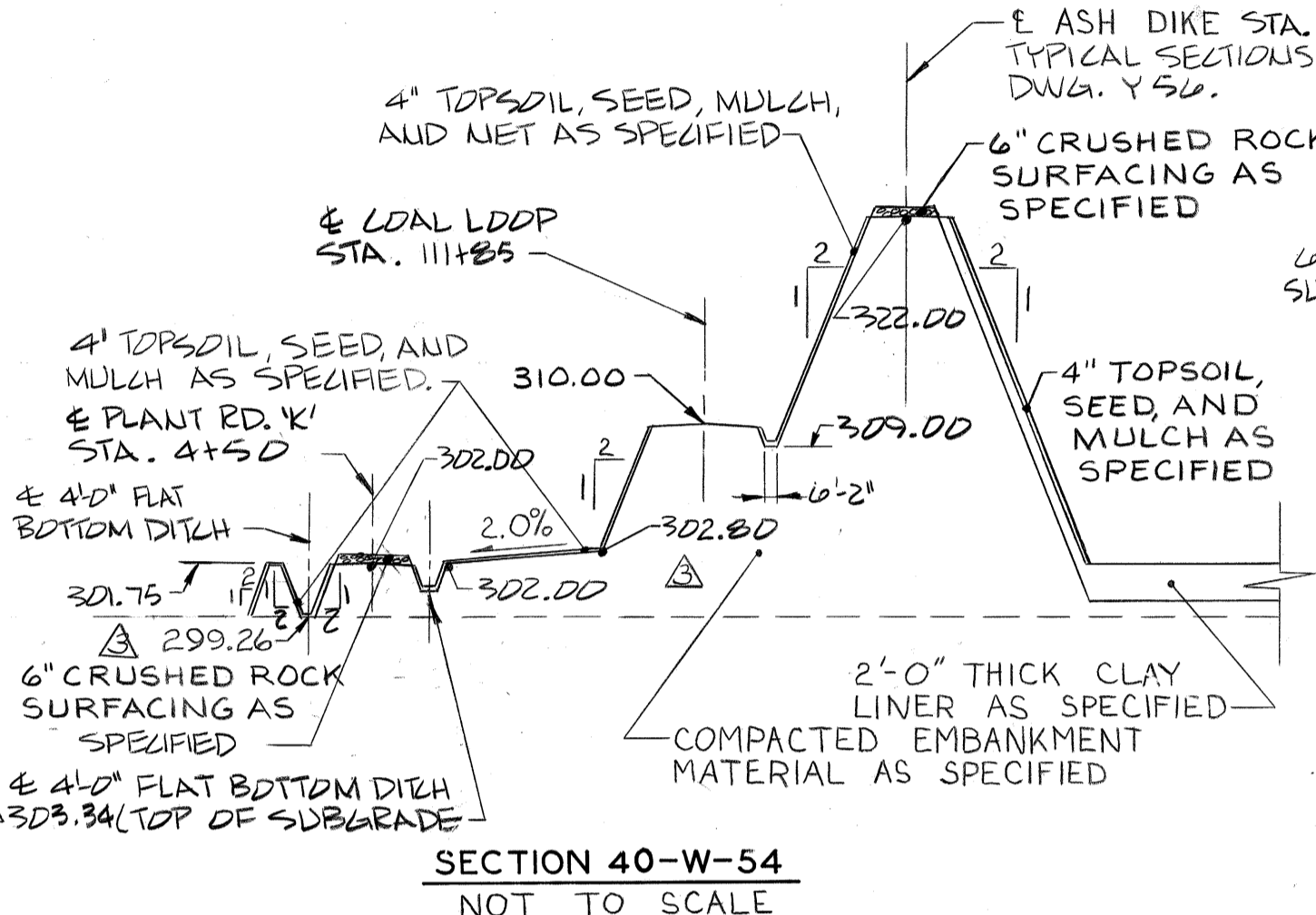
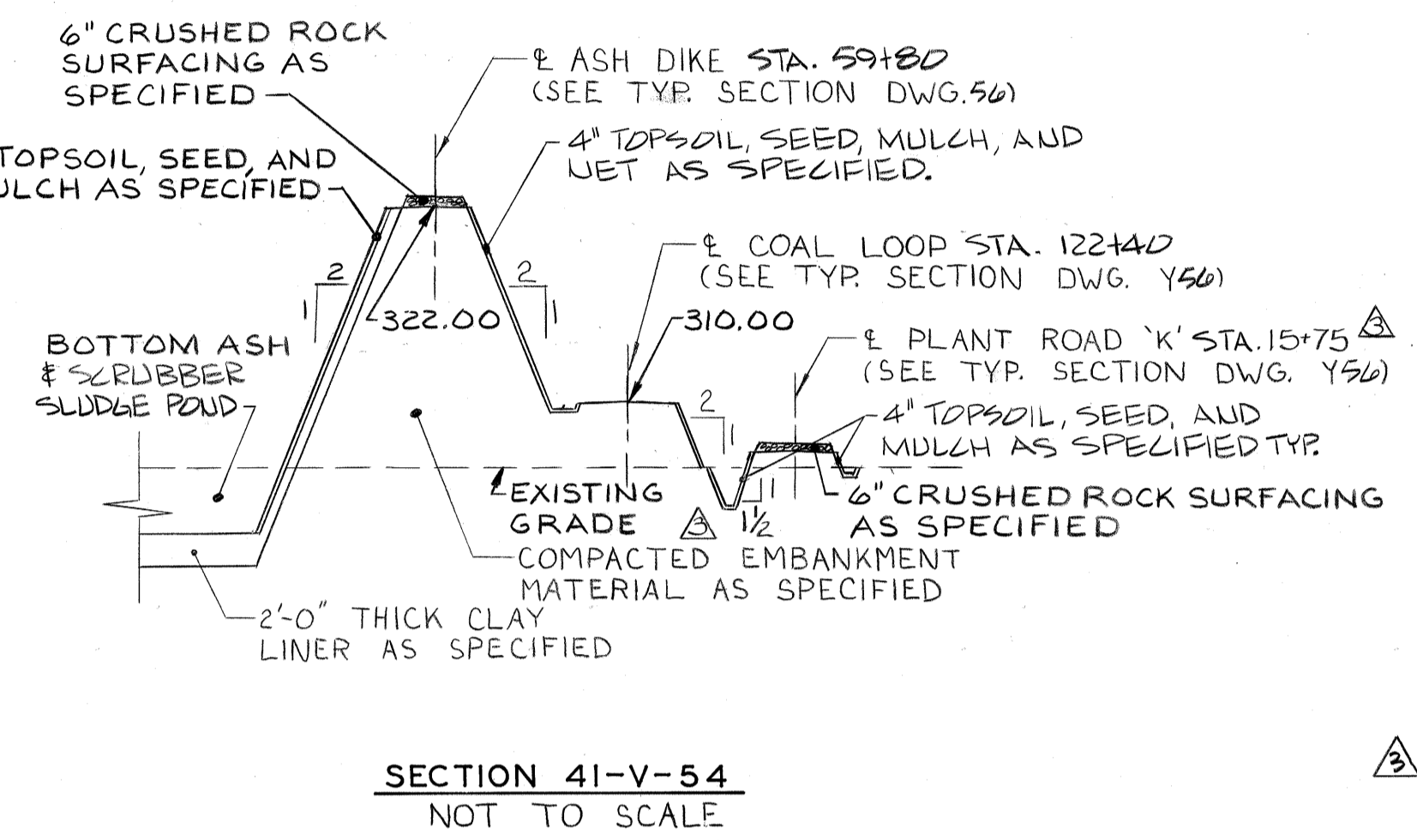
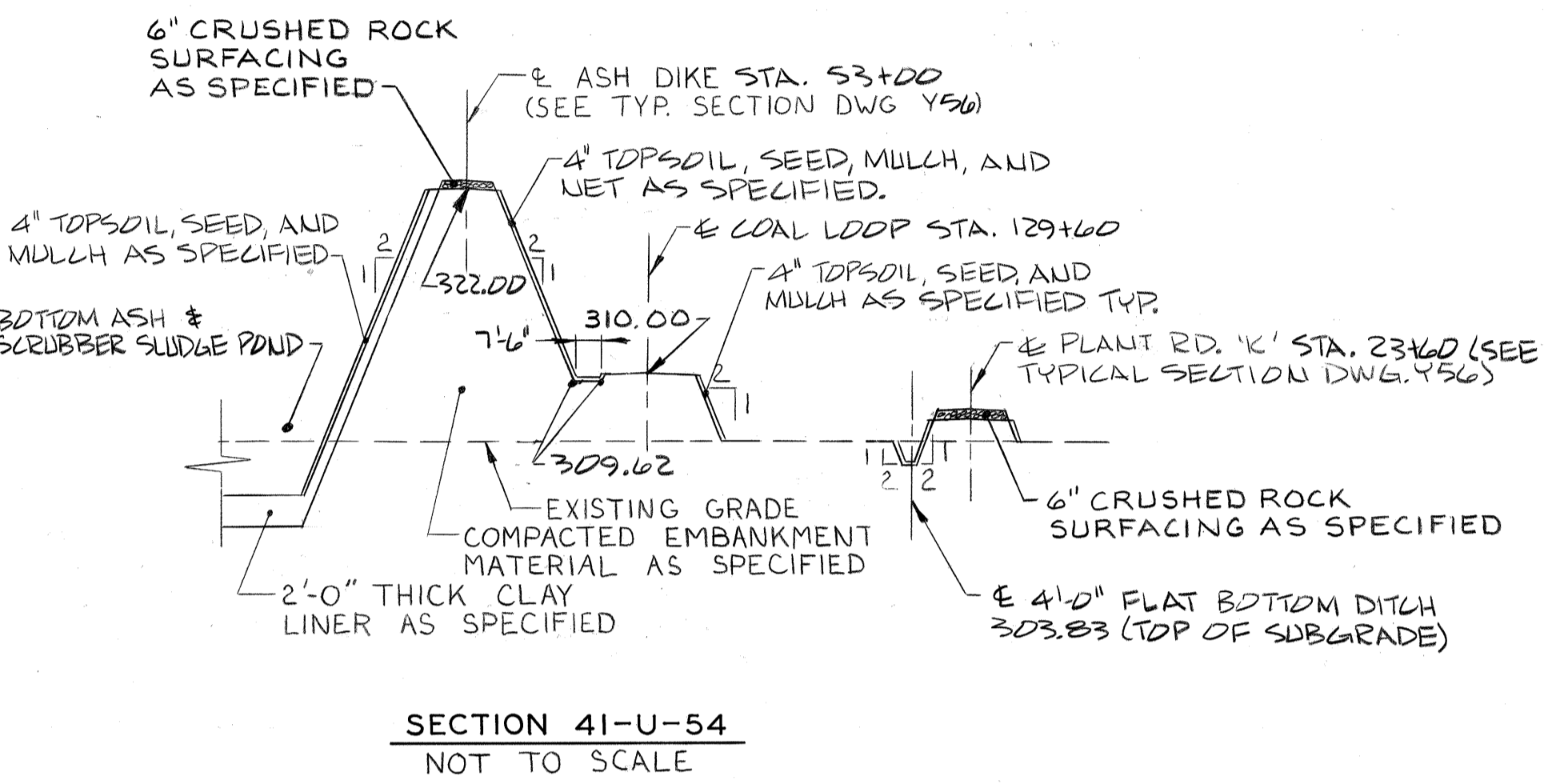
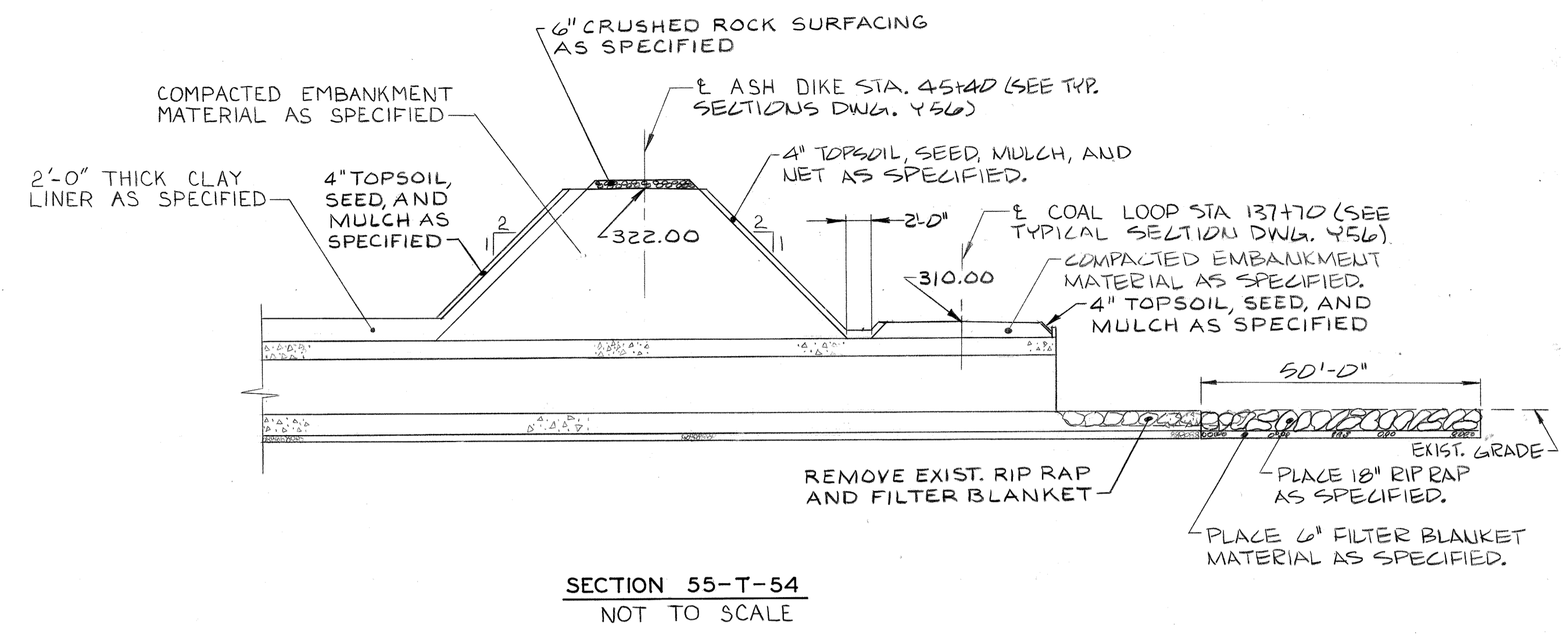
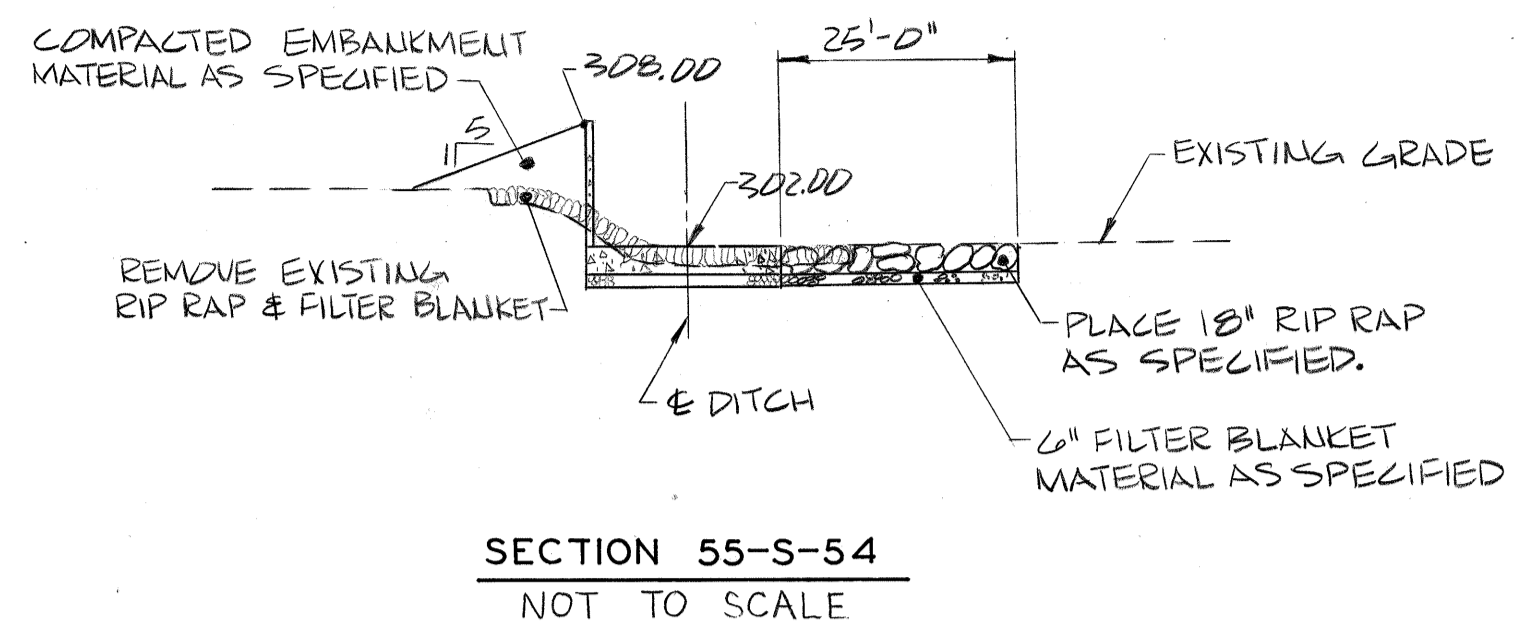
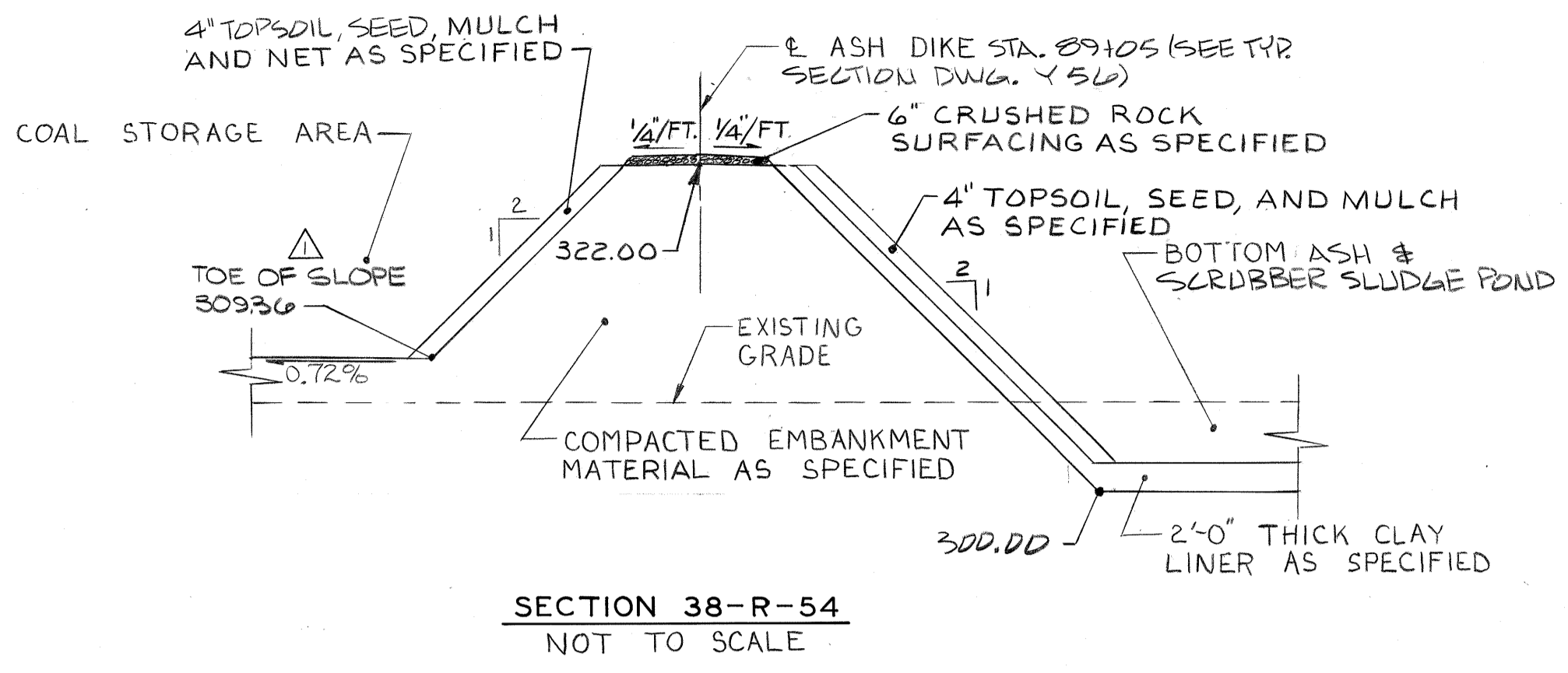

Scale in Centimeter

Scale in Inches

SITE PREPARATION 2
 GRADING SECTIONS II

SIKESTON POWER STATION
 UNIT NO. 1
 BOARD OF MUNICIPAL UTILITIES
PHELPS HOGLAND & PHILLIPS
 Engineering Company
BURNS & McDONNELL
 Engineers-Architects-Consultants

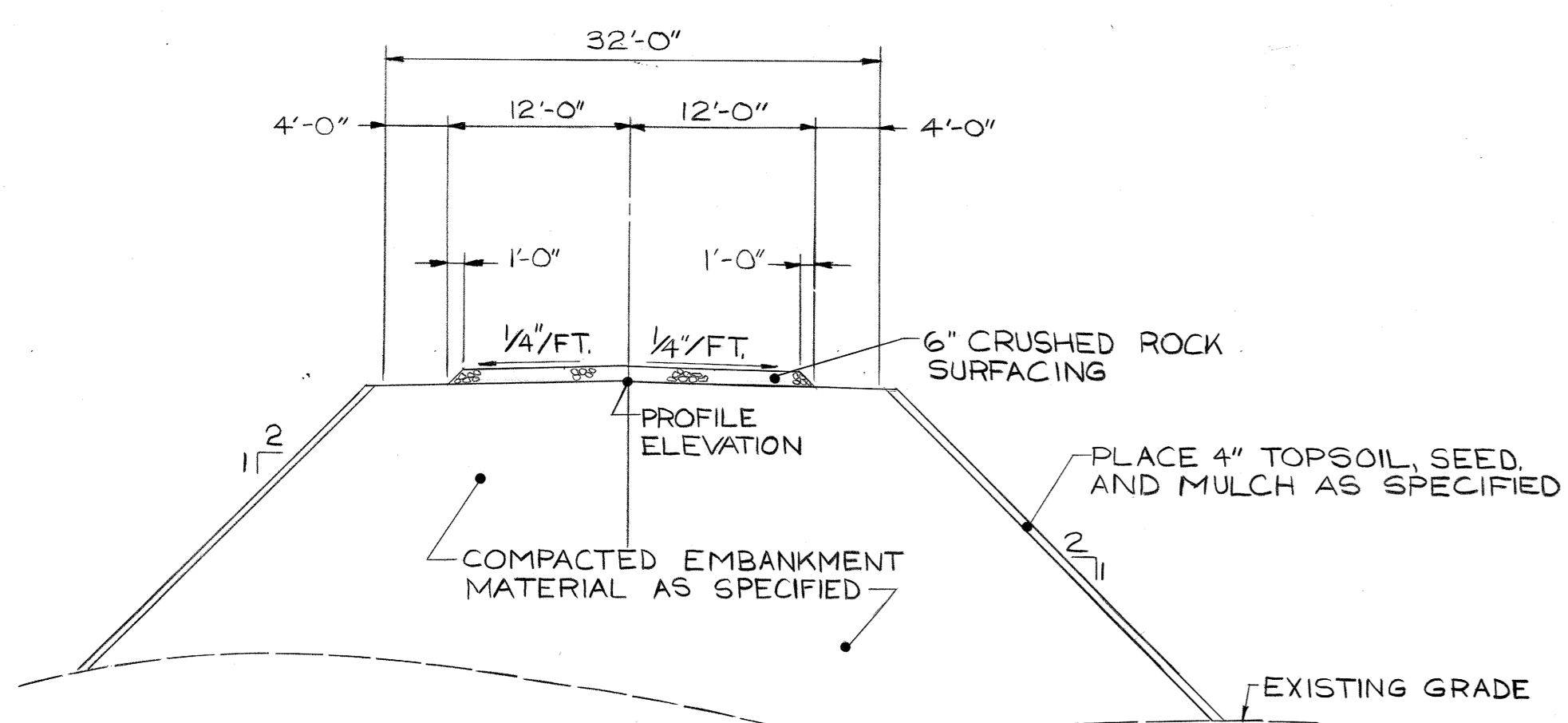

TYPICAL SECTION
MAIN ENTRANCE RD
NOT TO SCALE

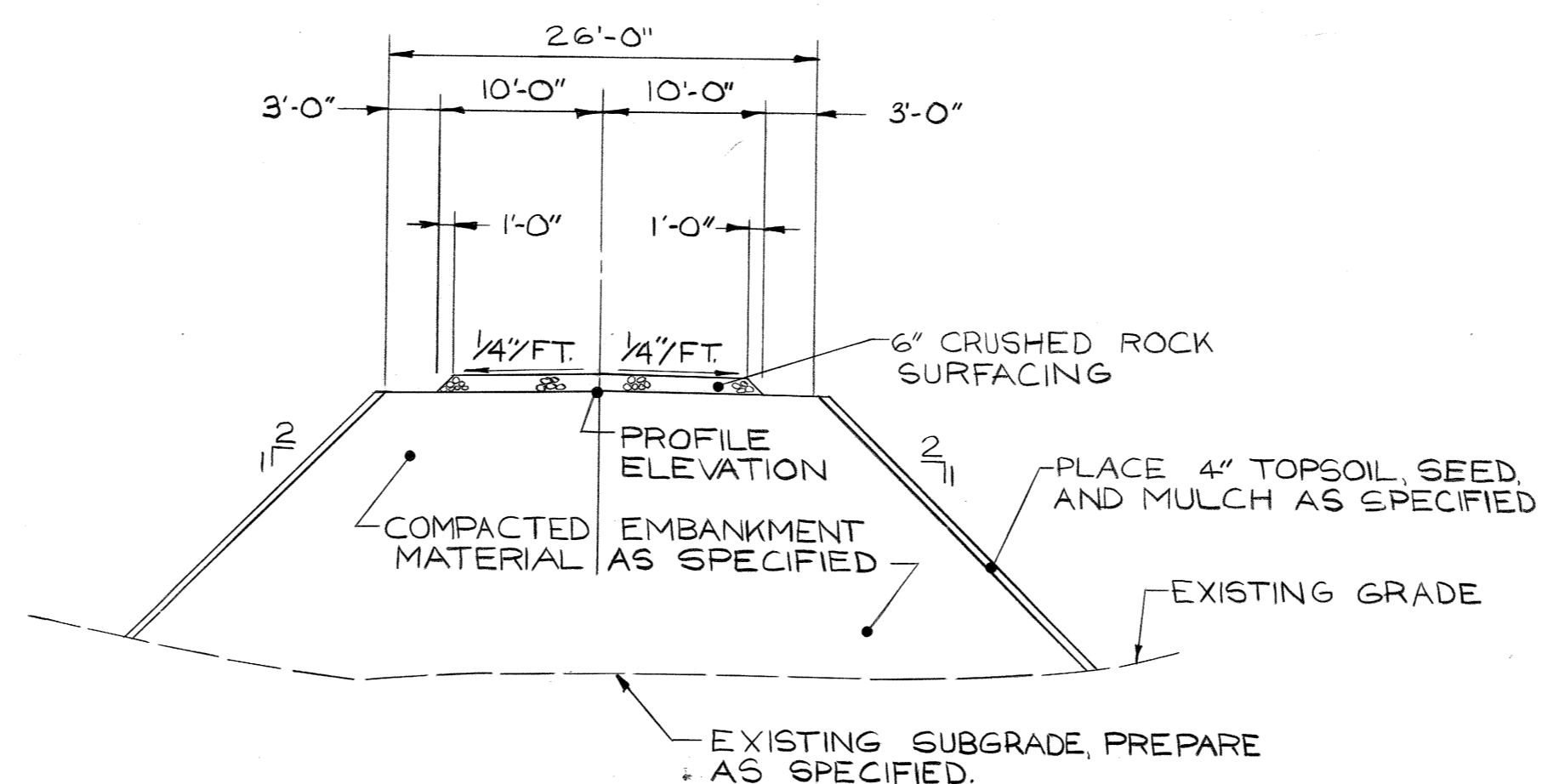

TYPICAL SECTION
PLANT RDS. A, B, E, F, G, & H
NOT TO SCALE

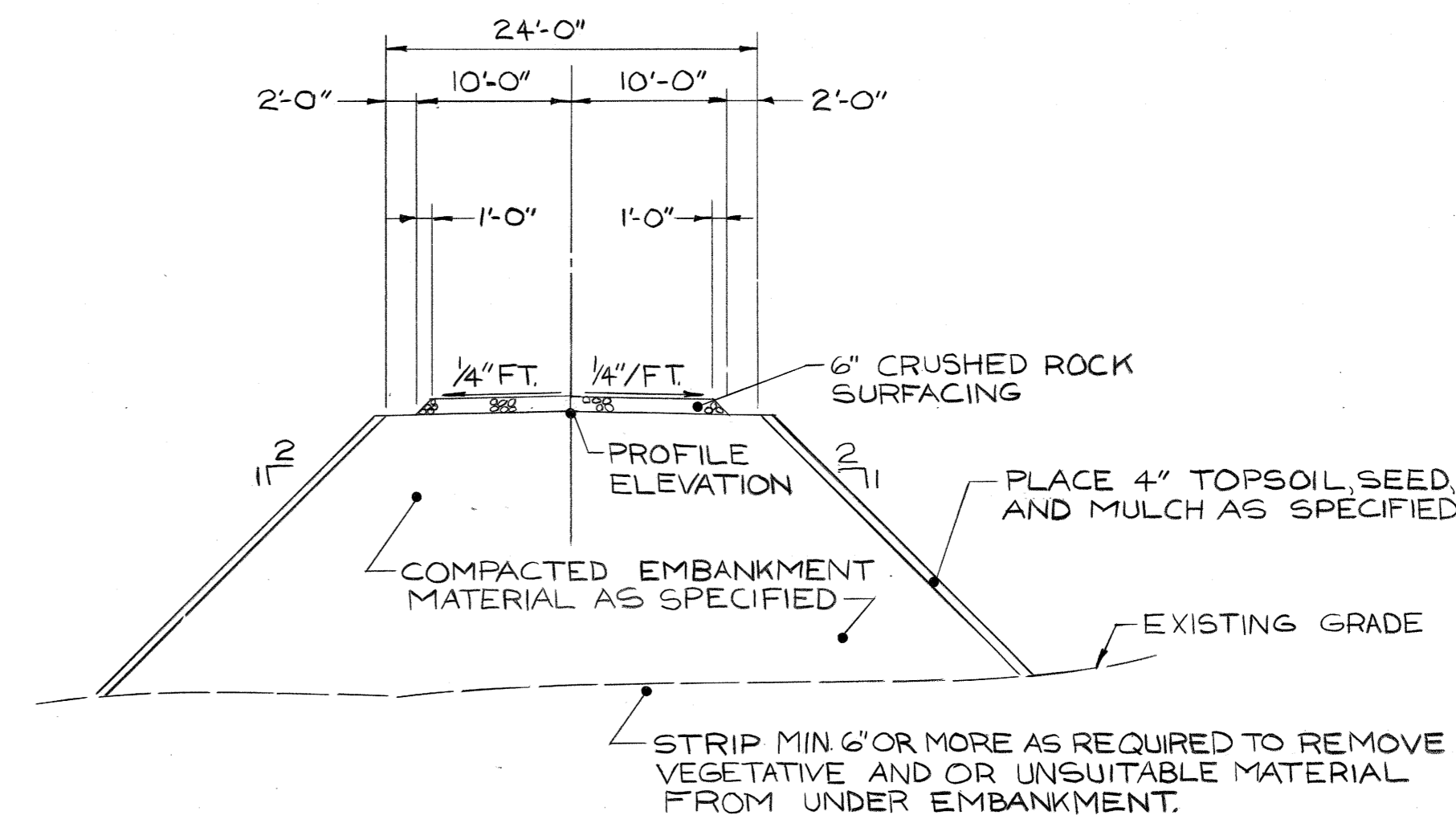

TYPICAL SECTION
PLANT RD. 'K'
NOT TO SCALE

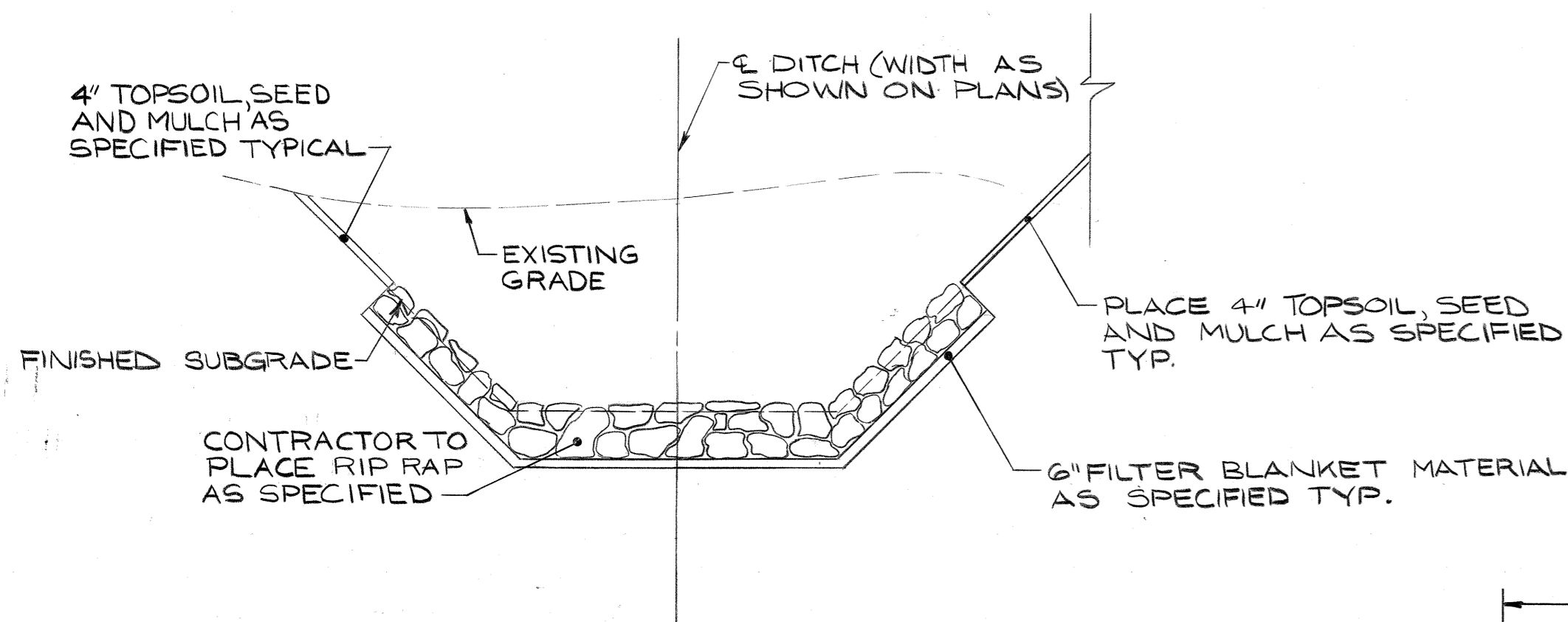

△△
RIP RAP PLACEMENT DETAIL
NOT TO SCALE

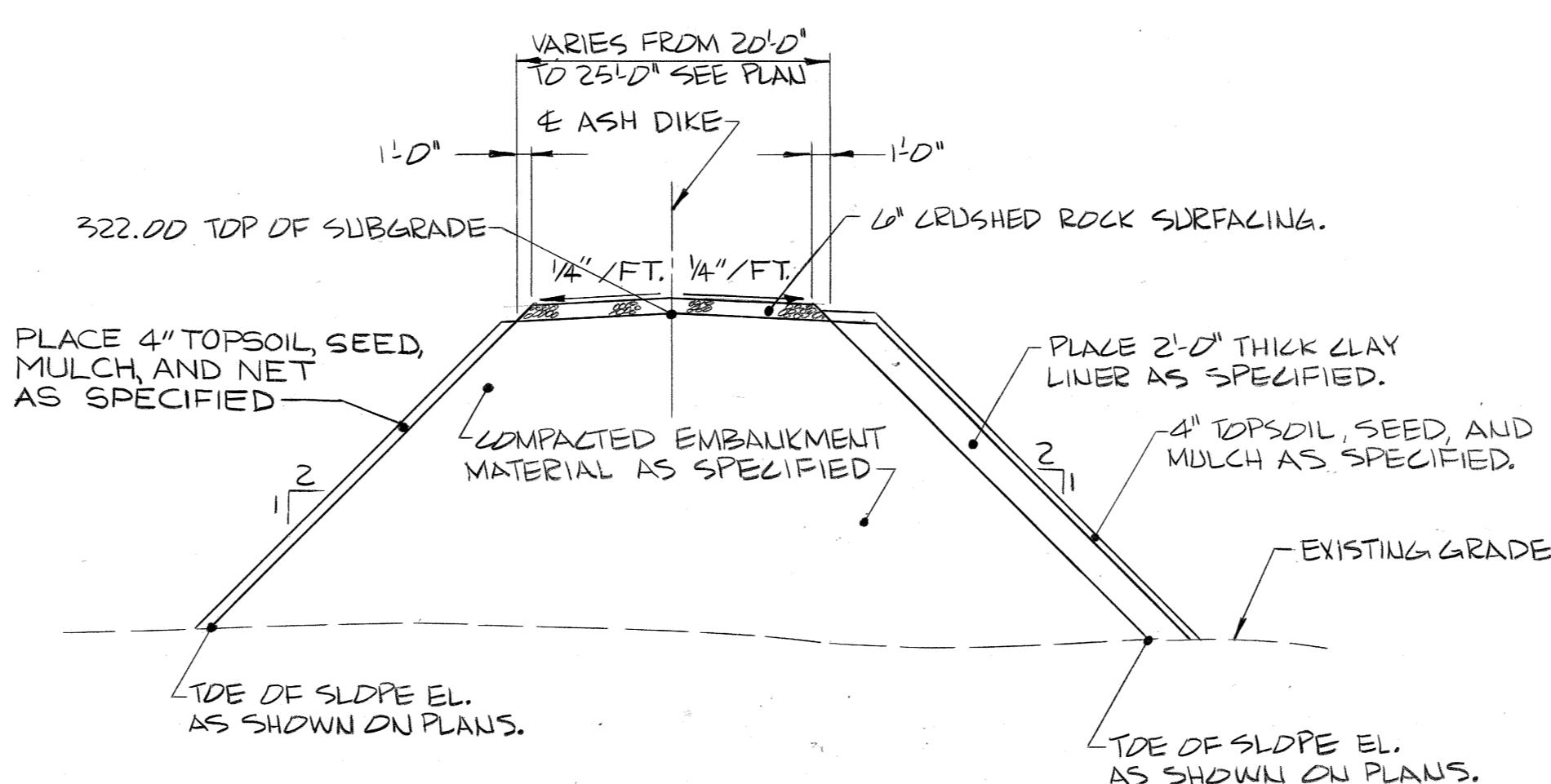

TYPICAL SECTION
ASH DIKE
STA. 0+00 TO STA. 91+50±
NOT TO SCALE

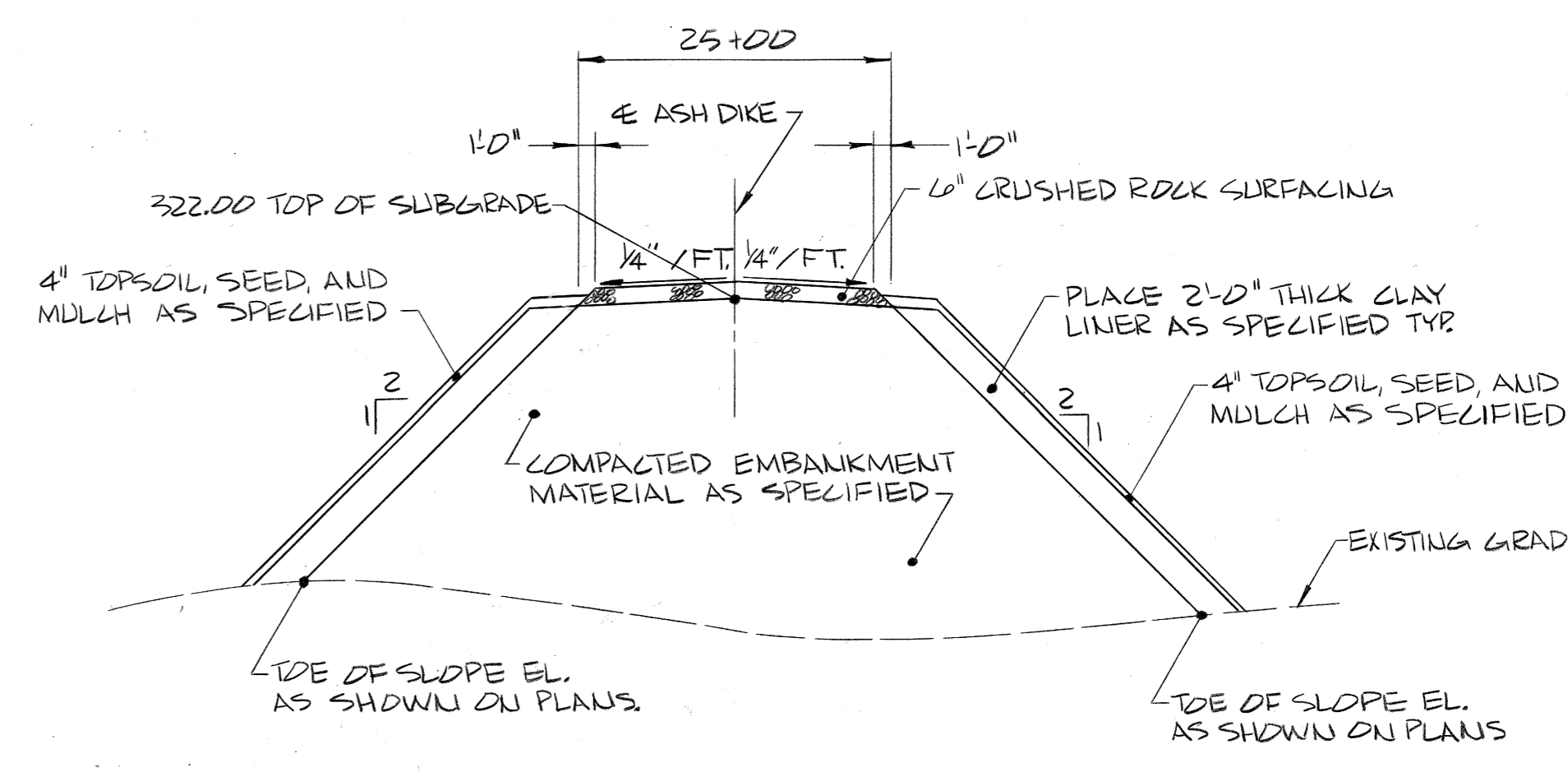

TYPICAL SECTION
ASH DIKE
STA. 91+50± TO STA. 100+20±
NOT TO SCALE

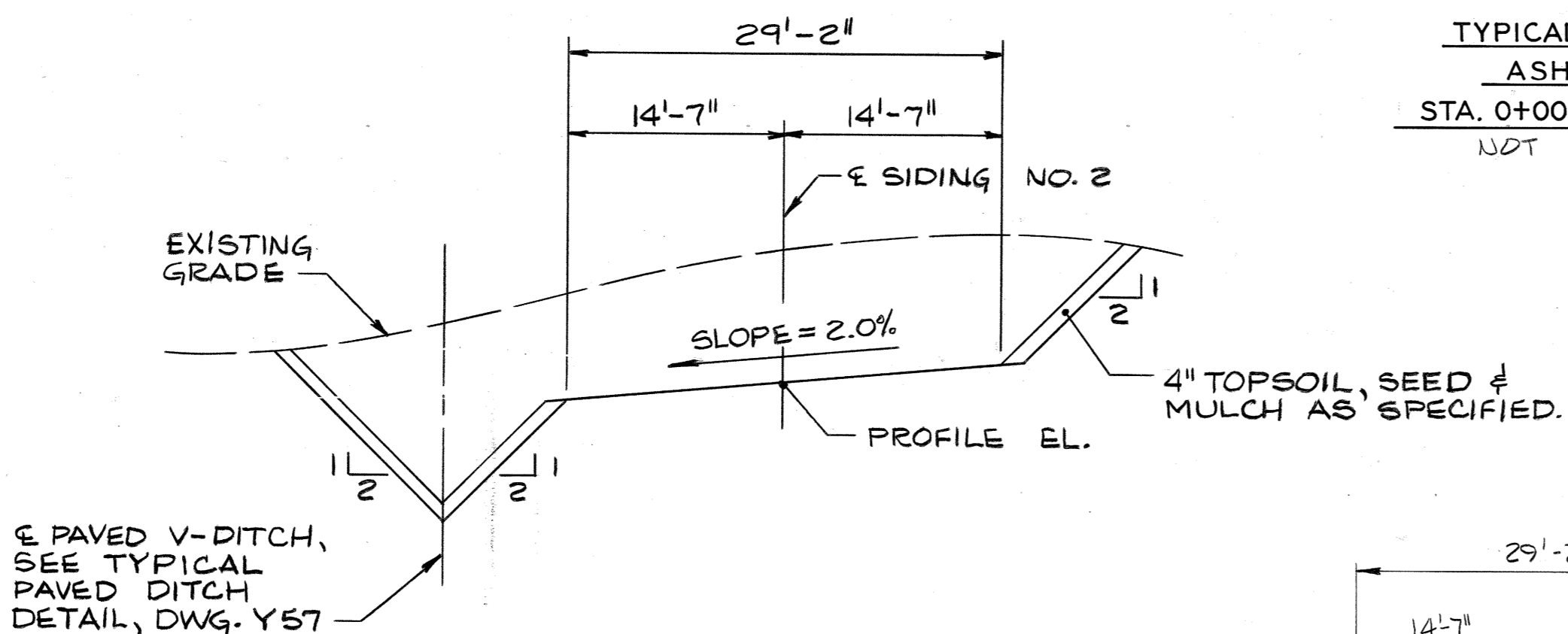

TYPICAL SECTION
SIDING NO. 2
NOT TO SCALE

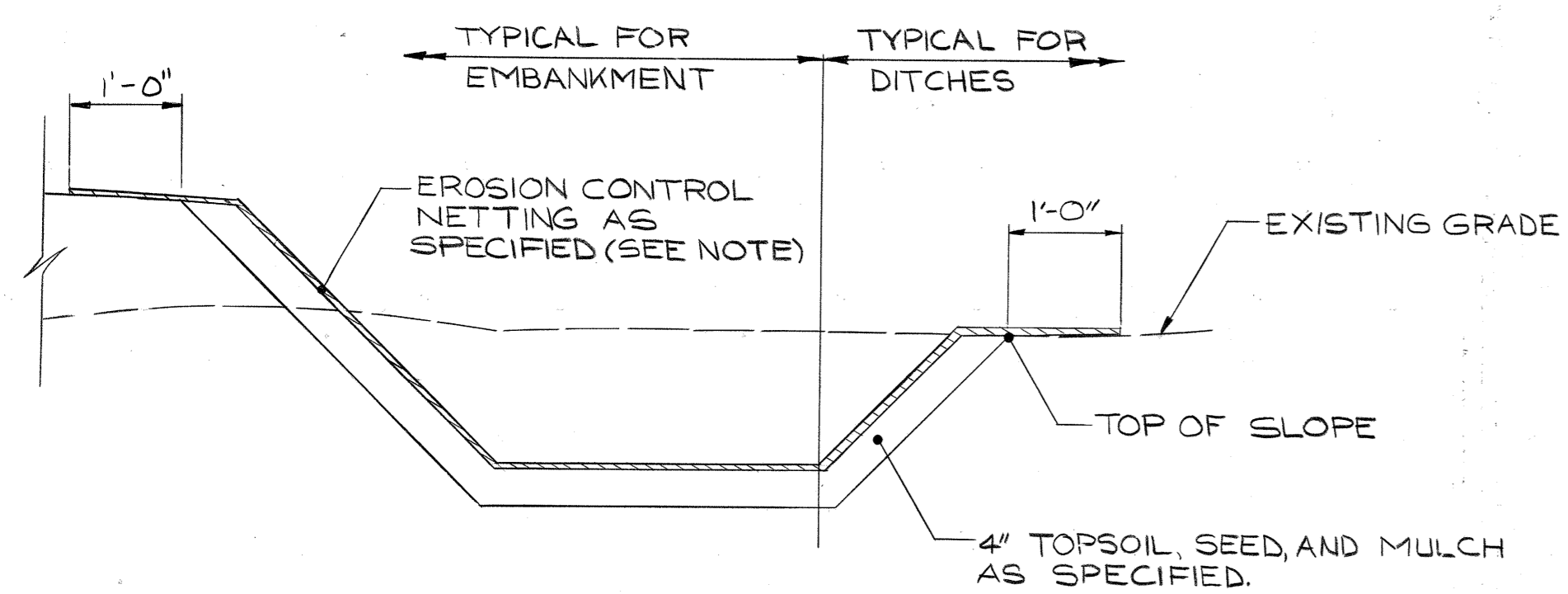

NOTE:
EROSION CONTROL NETTING TO BE
ANCHORED AS SPECIFIED.

NETTING PLACEMENT DETAIL
NOT TO SCALE

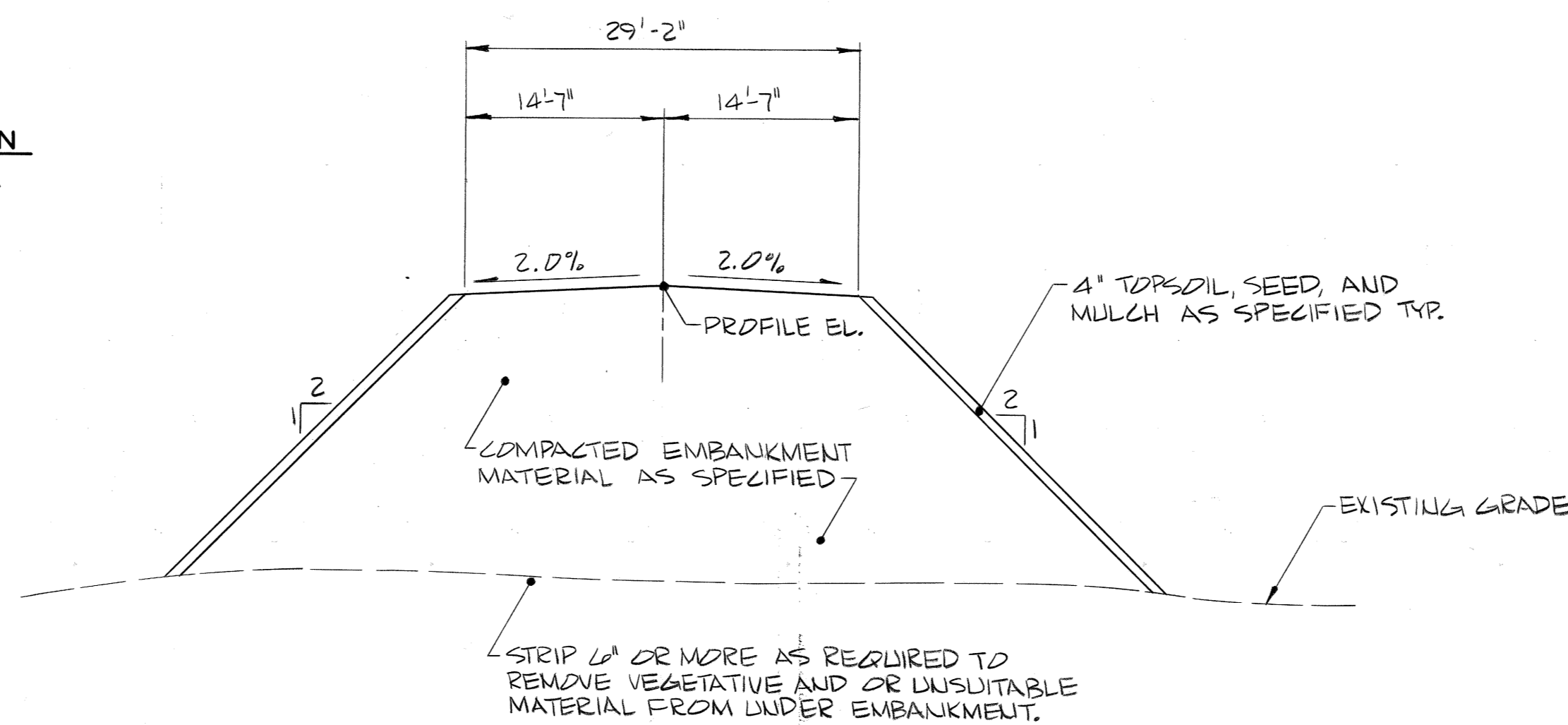

TYPICAL SECTION
SINGLE TRACK
NOT TO SCALE

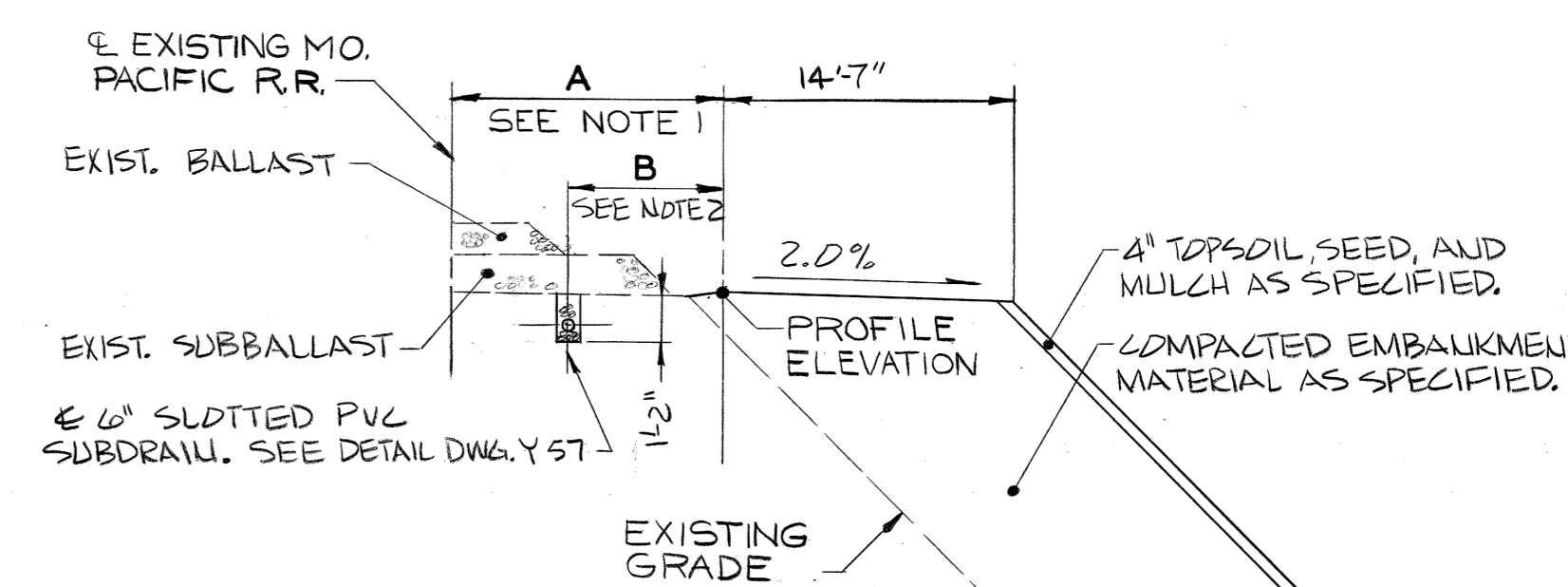

NOTES:
1. DIMENSION 'A' IS 17'-0" FOR MO. PACIFIC
ACCESS SPUR EAST AND 15'-0" MO.
PACIFIC ACCESS SPUR WEST.
2. DIMENSION 'B' IS 8'-6" FOR MO. PACIFIC
ACCESS SPUR EAST, AND 7'-6" FOR MO.
PACIFIC ACCESS SPUR WEST.

TYPICAL SECTION
DOUBLE TRACK
NOT TO SCALE

PROJECT 76-0761	
CONTRACT 33	
DATE JUNE 5, 1978	
DESIGNED KILE	
DETAILED ALLEN	
CHECKED JAA	

NO.	DATE	BY	REVISION
1	8-31-78	JAA	ISSUED AS BID
2	1-31-79	CLA	(2-2) REVISED RIP RAP PLACEMENT DETAIL PER CHANGE ORDER NO. 5
3	3-29-79	JAA	ISSUED
4	5-23-79	FOBA	(2-3) REVISED RIP RAP PLACEMENT DETAIL
5	5-29-79	JAA	ISSUED
6	6-14-82	RGP	CONFORMED TO CONSTRUCTION RECORDS

SITE PREPARATION 2
TYPICAL SECTIONS AND GRADING DETAILS

SIKESTON POWER STATION
UNIT NO. 1
BOARD OF MUNICIPAL UTILITIES
PHELPS HOGLAND & PHILLIPS
Engineering Company
BURNS & McDONNELL
Engineers-Architects-Consultants

DRAWING NO.	SHEET	OF	SHEETS	REV.
Y56			3	

NO.	DATE	BY	REVISION
2-31-78	JAA		ISSUED AS BID
6-14-82	RGP		CONFORMED TO CONSTRUCTION RECORDS

NO.	DATE	BY	REVISION
1			

NO.	DATE	BY	REVISION
1			

NO.	DATE	BY	REVISION
1			

NO.	DATE	BY	REVISION
1			

NO.	DATE	BY	REVISION
1			

NO.	DATE	BY	REVISION
1			

NO.	DATE	BY	REVISION
1			

NO.	DATE	BY	REVISION
1			

NO.	DATE	BY	REVISION
1			

NO.	DATE	BY	REVISION
1			

NO.	DATE	BY	REVISION
1			

NO.	DATE	BY	REVISION
1			

NO.	DATE	BY	REVISION
1			

NO.	DATE	BY	REVISION
1			

NO.	DATE	BY	REVISION
1			

NO.	DATE	BY	REVISION
1			

NO.	DATE	BY	REVISION
1			

NO.	DATE	BY	REVISION
1			

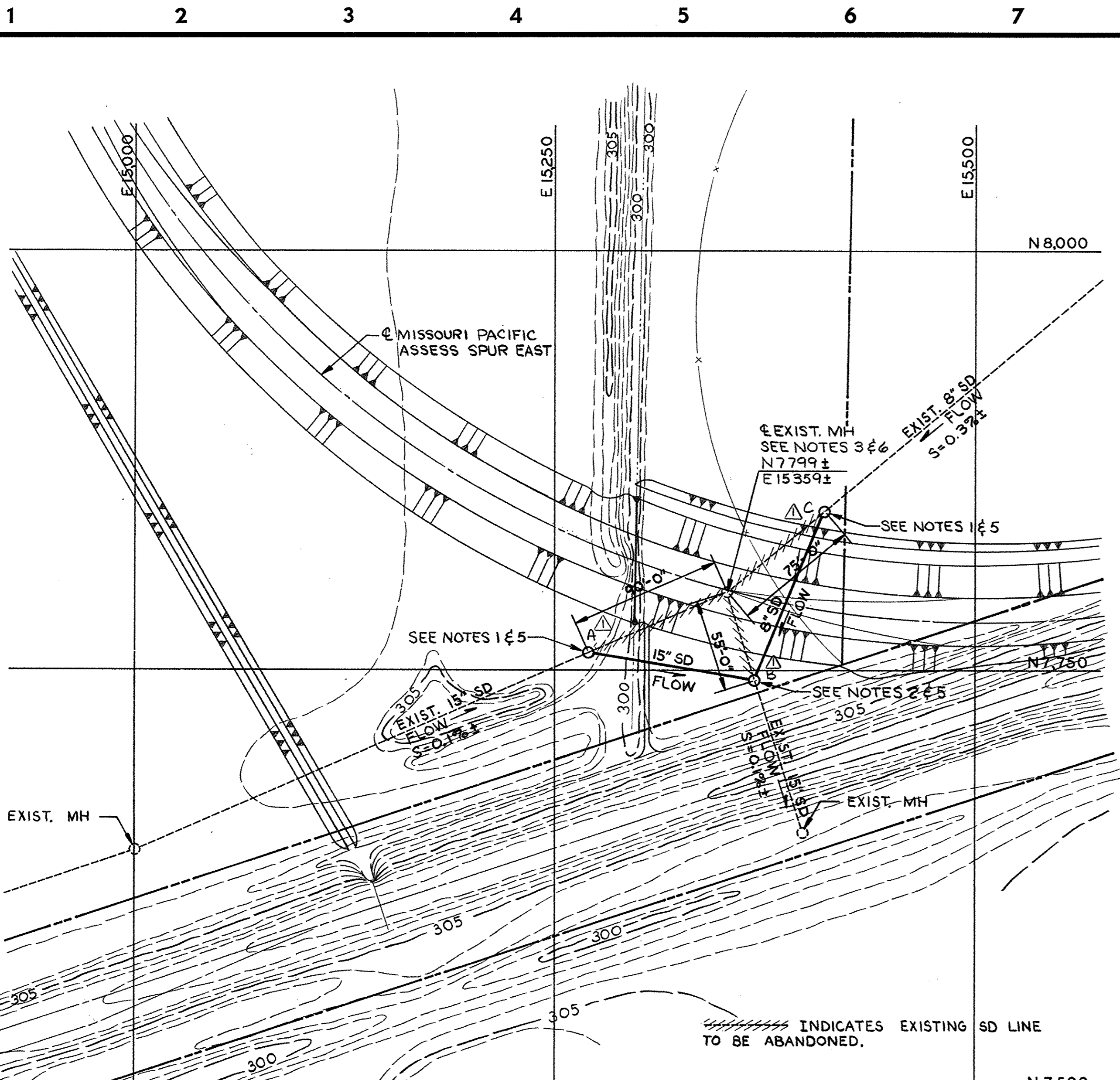

- NOTES:
- REMOVE ABANDONED EXISTING SD LINE TO FIRST JOINT BEYOND MH EXCAVATION AND INSTALL WATER TIGHT CAP OR PLUG. INSTALL PRECAST MANHOLE WITH PIPE SUPPORT TO FIRST JOINT BEYOND MH EXCAVATION & 1'-0" MIN INTO TYP. TRENCH SECTION. SET EFFLUENT INVERT 1/2" LOWER THAN EXISTING INFLUENT INVERT.
 - REMOVE ABANDONED EXISTING SD LINE TO FIRST JOINT BEYOND MH EXCAVATION AND INSTALL WATER TIGHT CAP OR PLUG. INSTALL PRECAST MANHOLE WITH PIPE SUPPORT TO FIRST JOINT BEYOND MH EXCAVATION & 1'-0" MIN INTO TYP. TRENCH SECTION. SET INFLUENT INVERT 1/2" HIGHER THAN EXISTING EFFLUENT INVERT.
 - REMOVE EXISTING MH FRAME & COVER AND SALVAGE AS PER ENGINEERS INSTRUCTIONS. CONCRETE FILL EXISTING MH.
 - EXISTING SANITARY DRAIN LINES ARE VITRIFIED CLAY PIPE.
 - PROVIDE ABS O-RING TYPE COUPLING W/MANHOLE WATER STOP WHERE NEW ABS SANITARY DRAIN LINES CONNECT TO MANHOLES.
 - EXISTING SD LINES ENTER & EXIT THE EXISTING M.H. AT E1. 2952.

DETAIL 1
RELOCATION OF EXIST. SANITARY SEWER

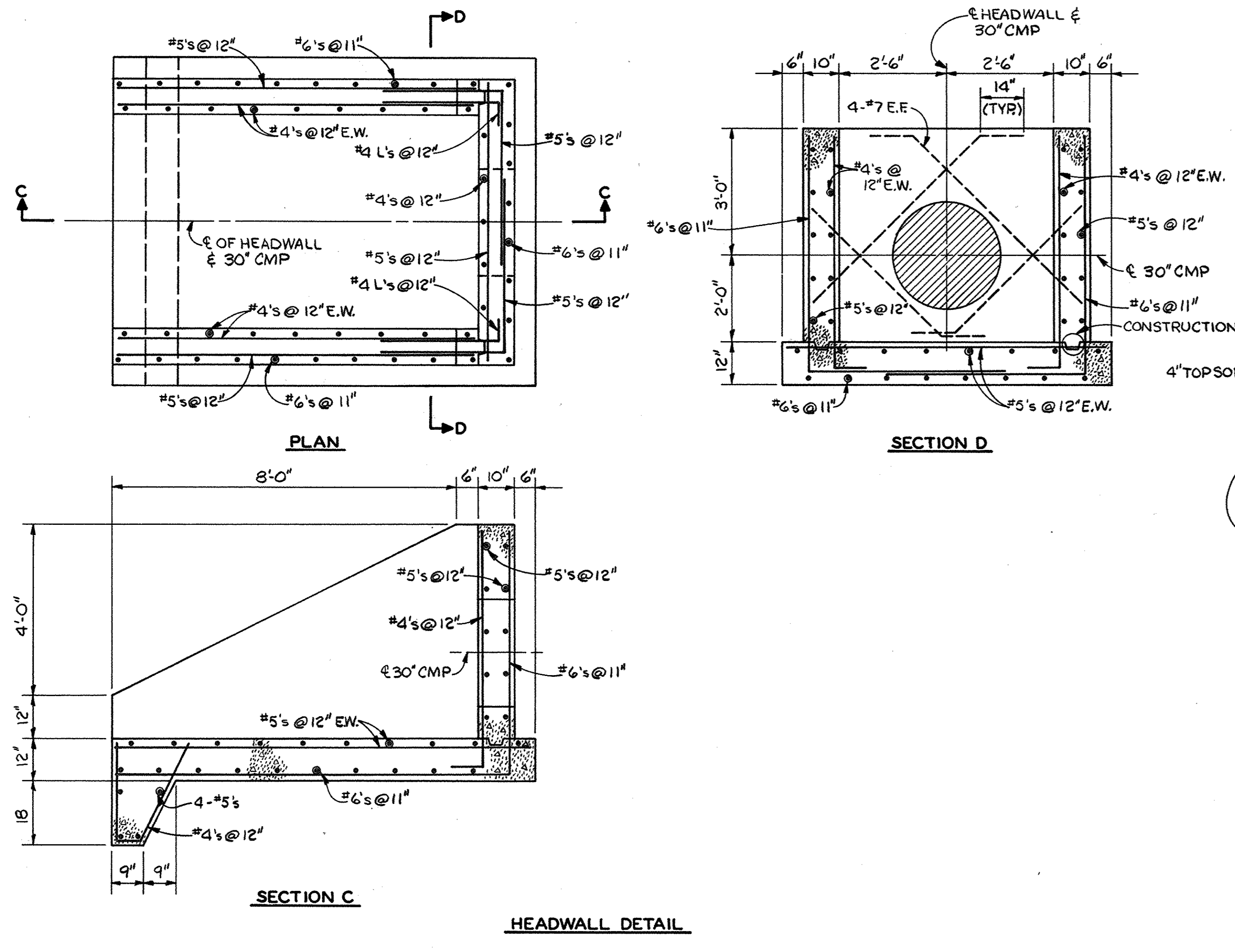
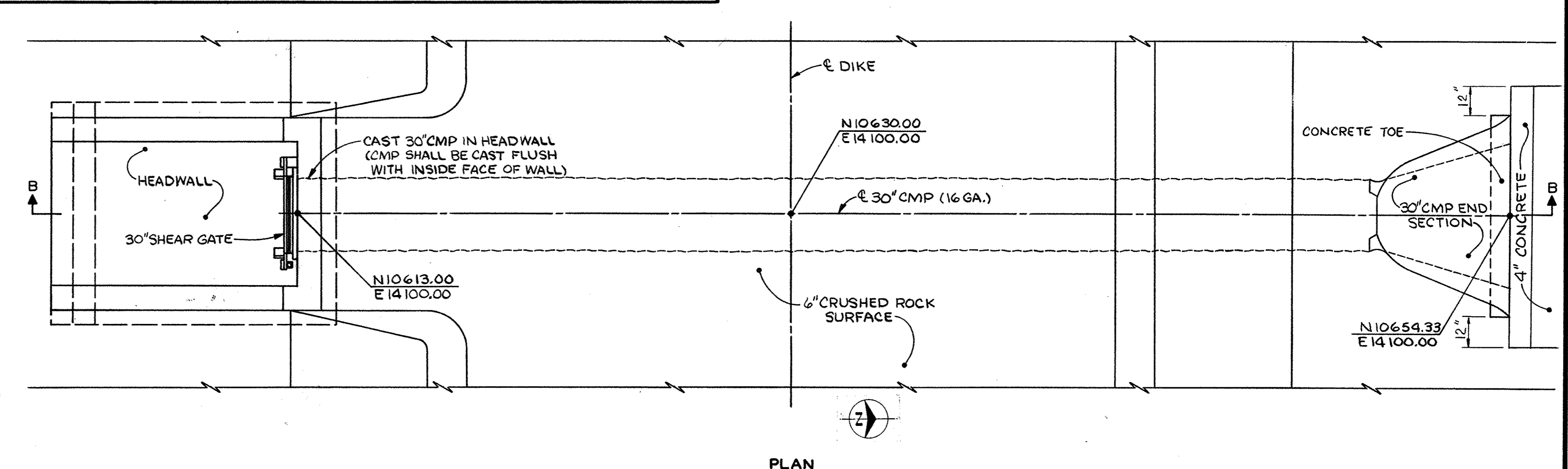
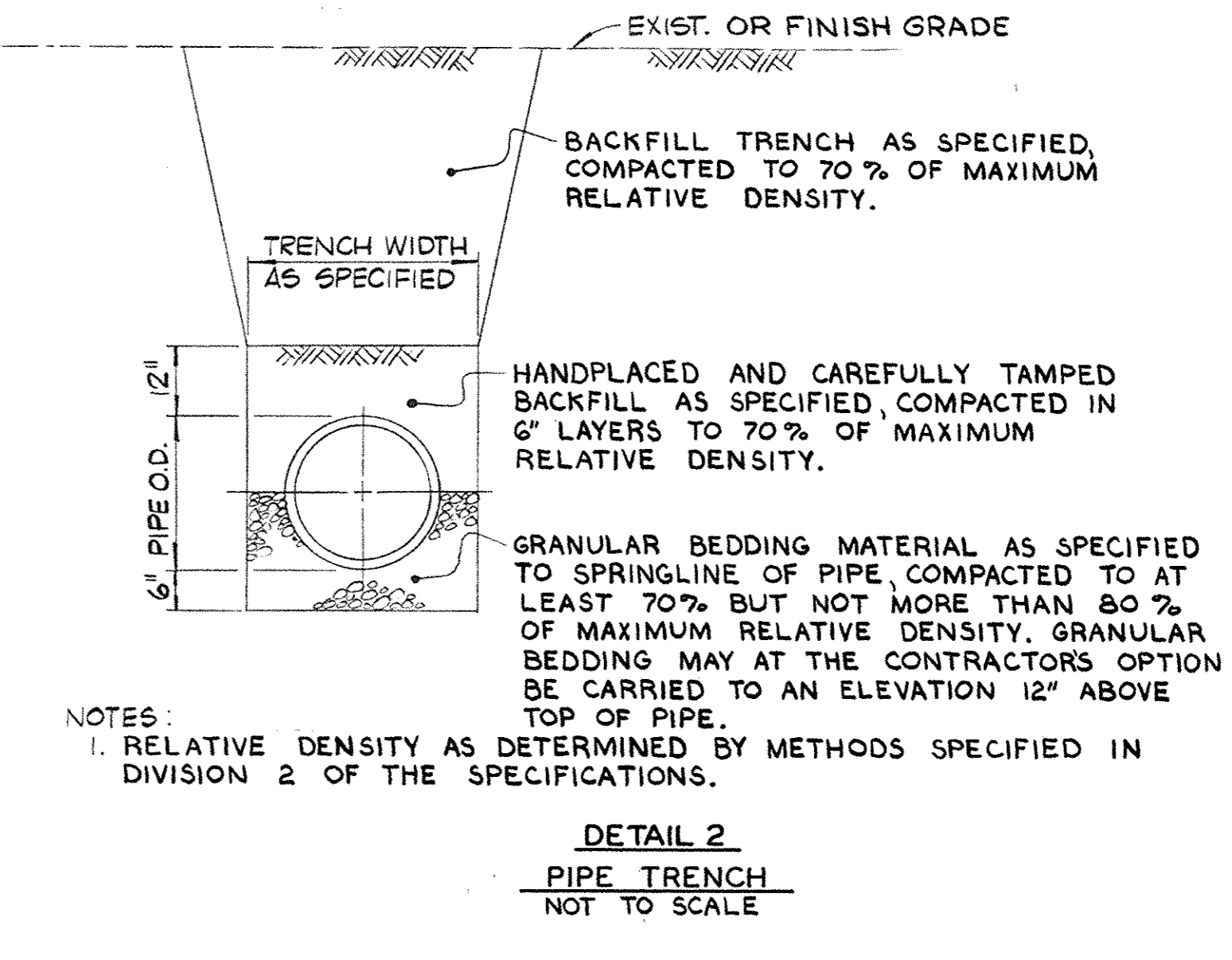
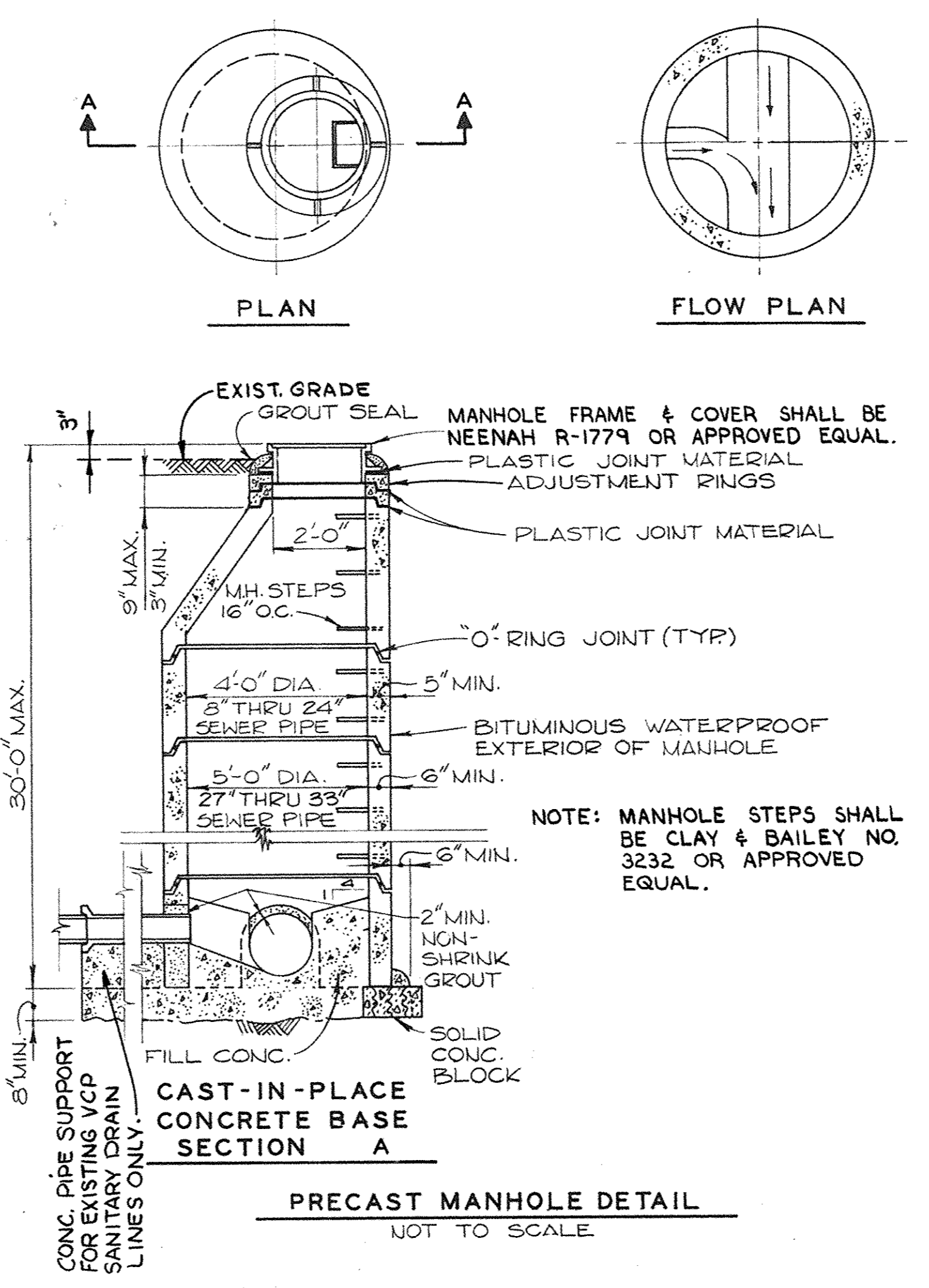

DETAIL 3
BOTTOM ASH & SCRUBBER SLUDGE POND OVERFLOW
NOT TO SCALE

SITE PREPARATION 2
YARD PIPING DETAILS I

SIKESTON POWER STATION
 UNIT NO. 1
 BOARD OF MUNICIPAL UTILITIES

PHELPS HOGLAND & PHILLIPS
 Engineering Company

BURNS & McDONNELL
 Engineers-Architects-Consultants

DRAWING NO. SHEET OF SHEETS REV.

UP14

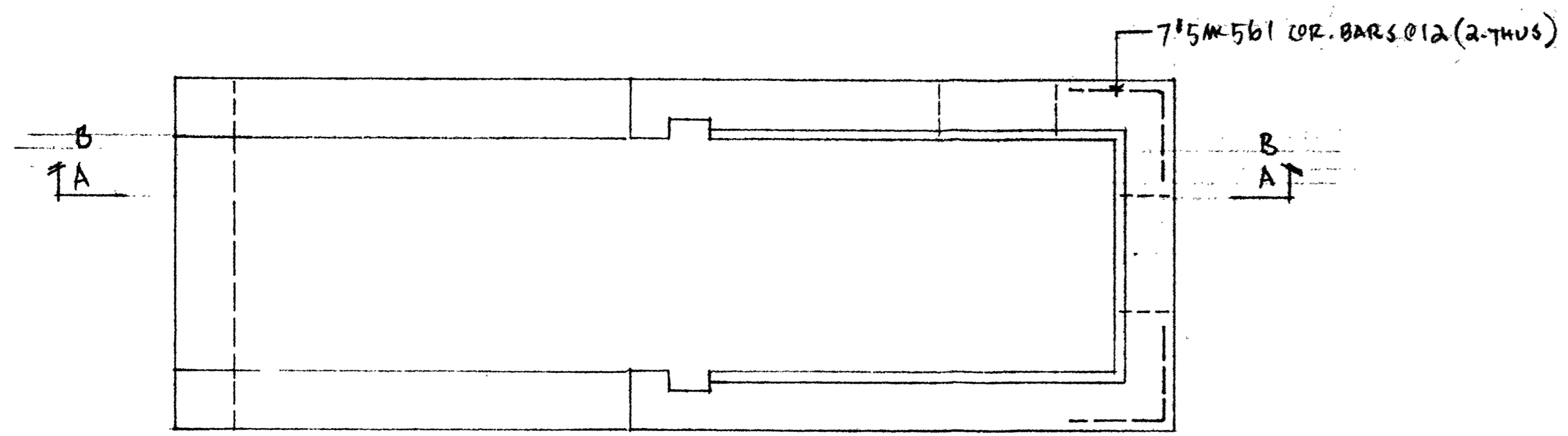

PLAN - FLY ASH POND OVERFLOW STRUCTURE

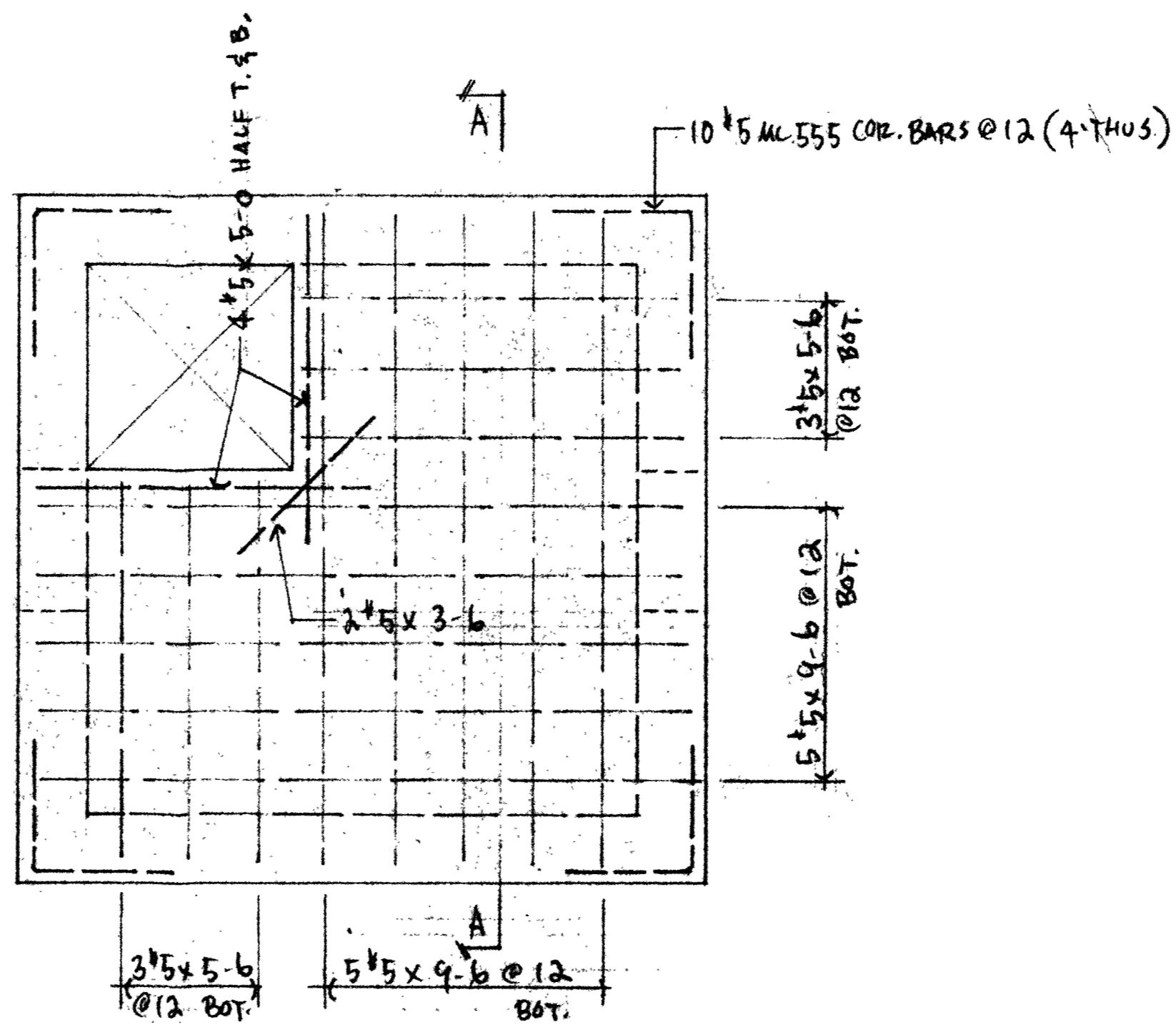

PLAN - FLY ASH POND OVERFLOW MONITORING STRUCTURE

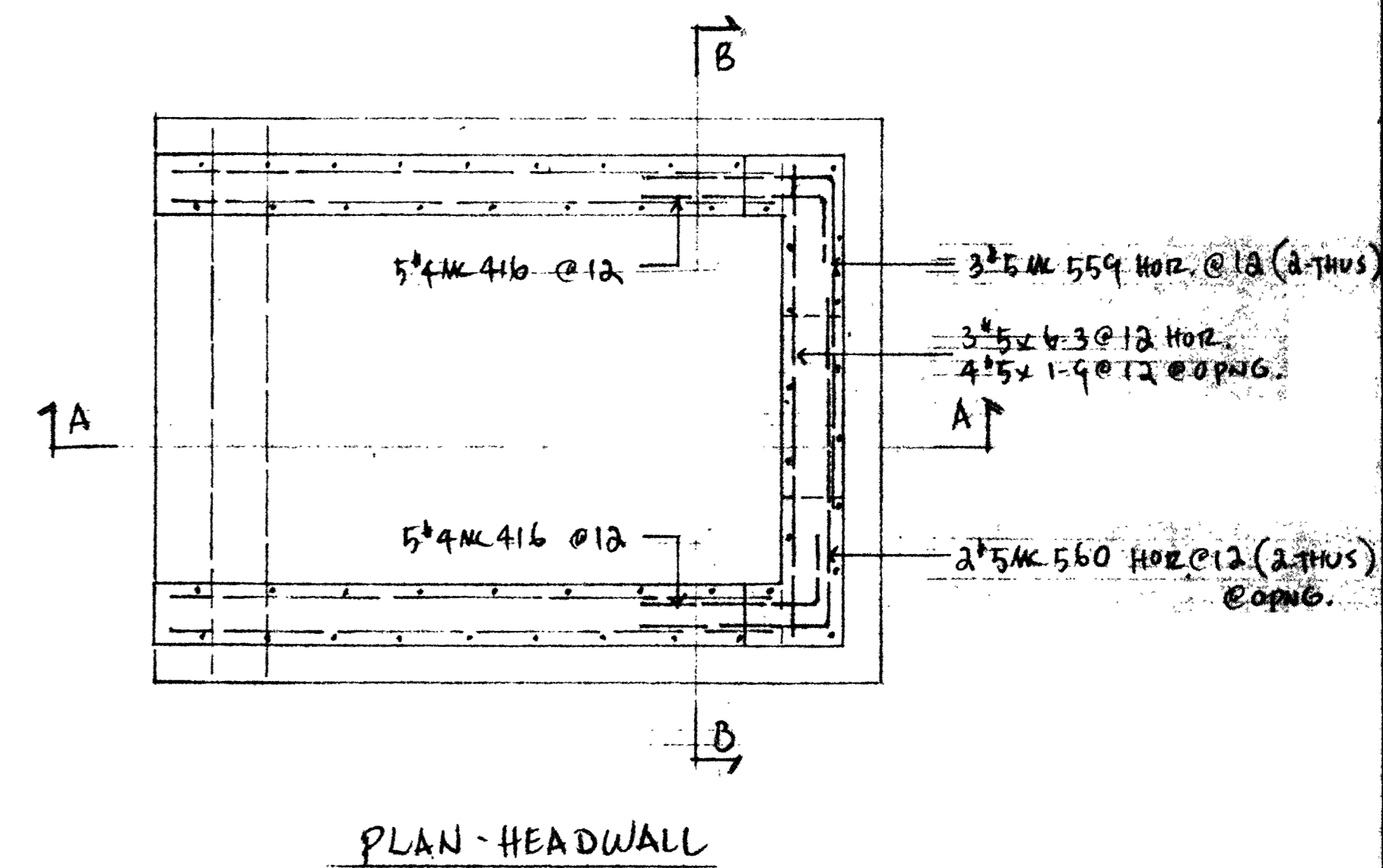

PLAN - HEADWALL

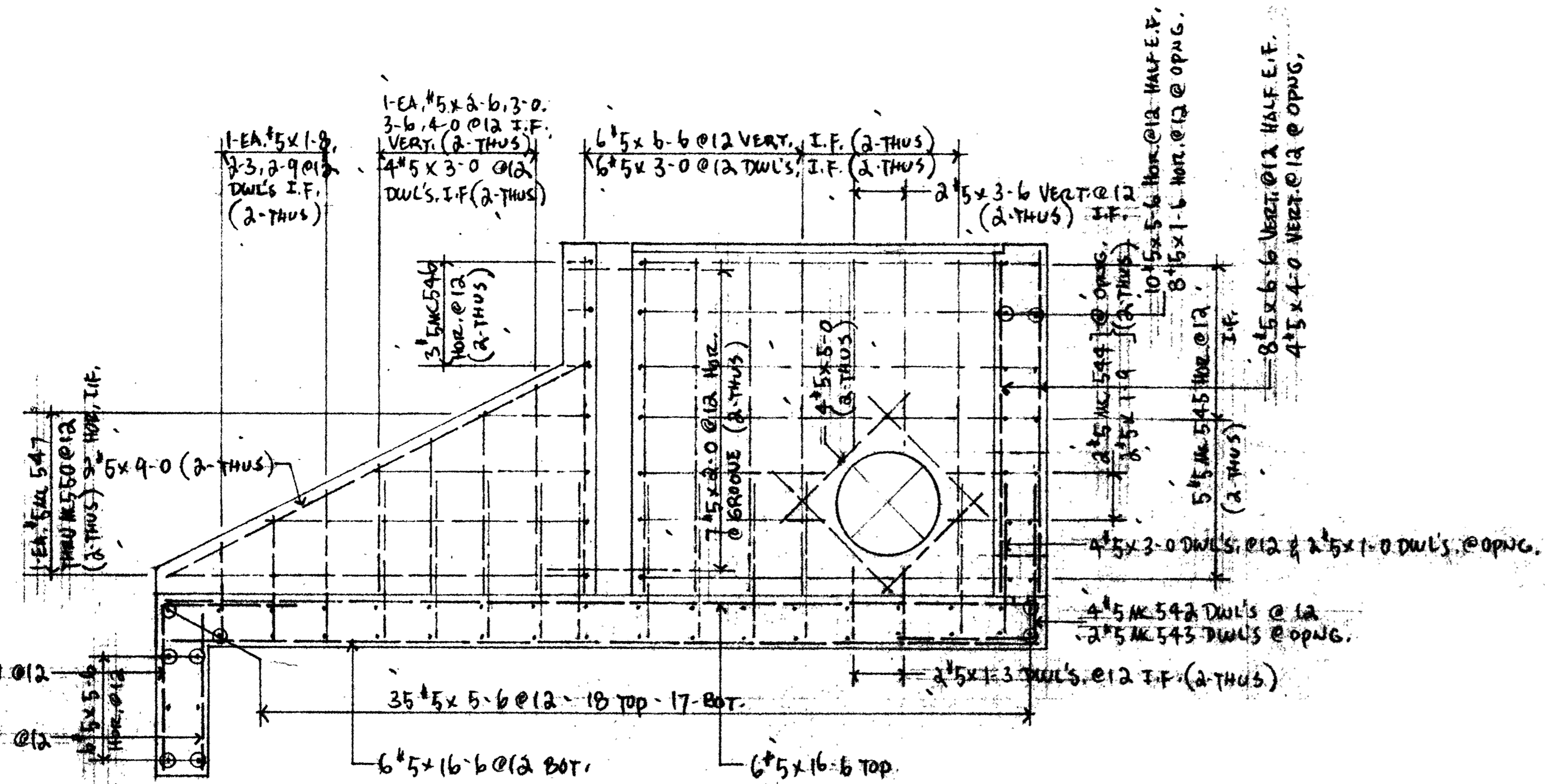

SECTION - A-A

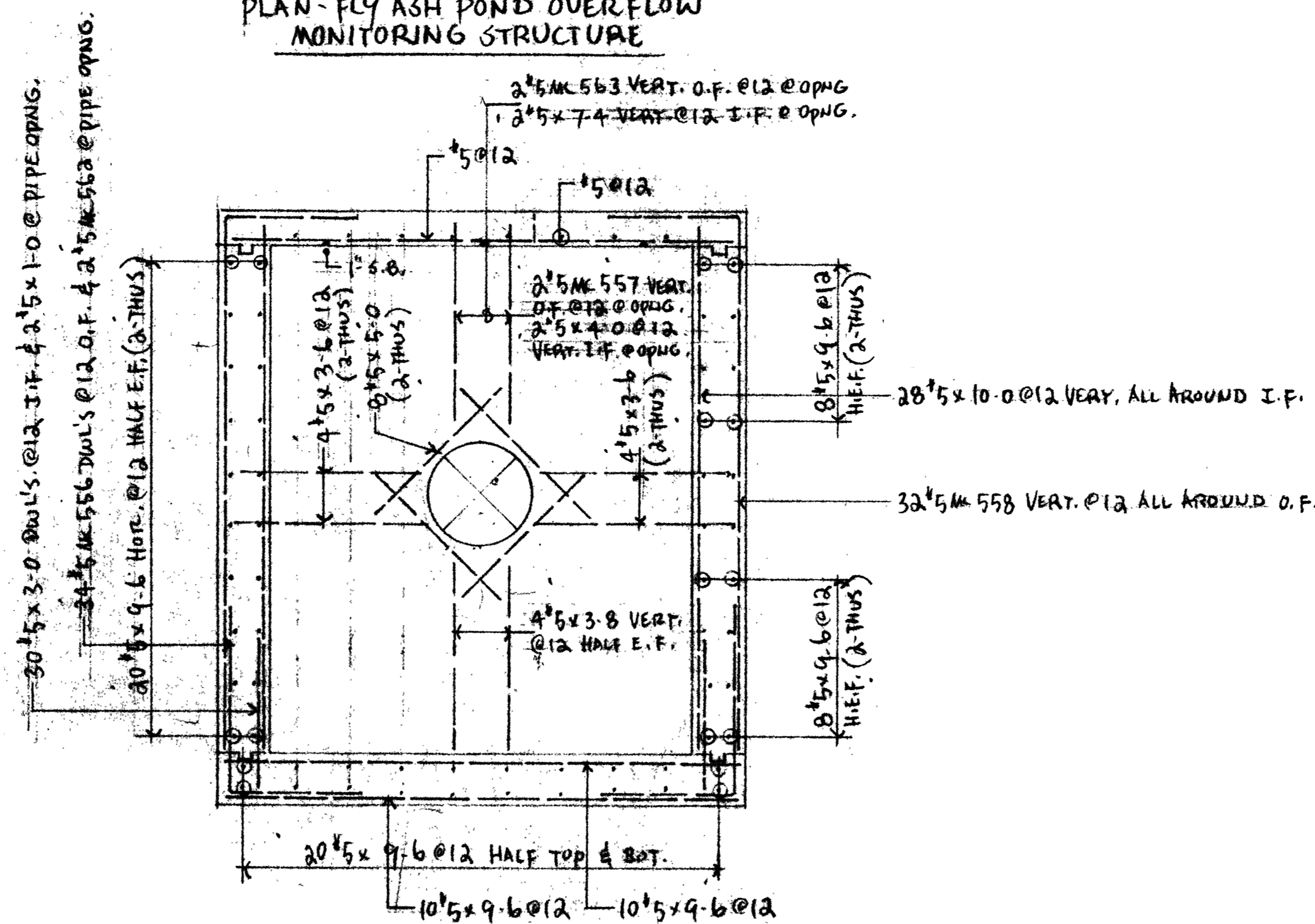

SECTION - A-A

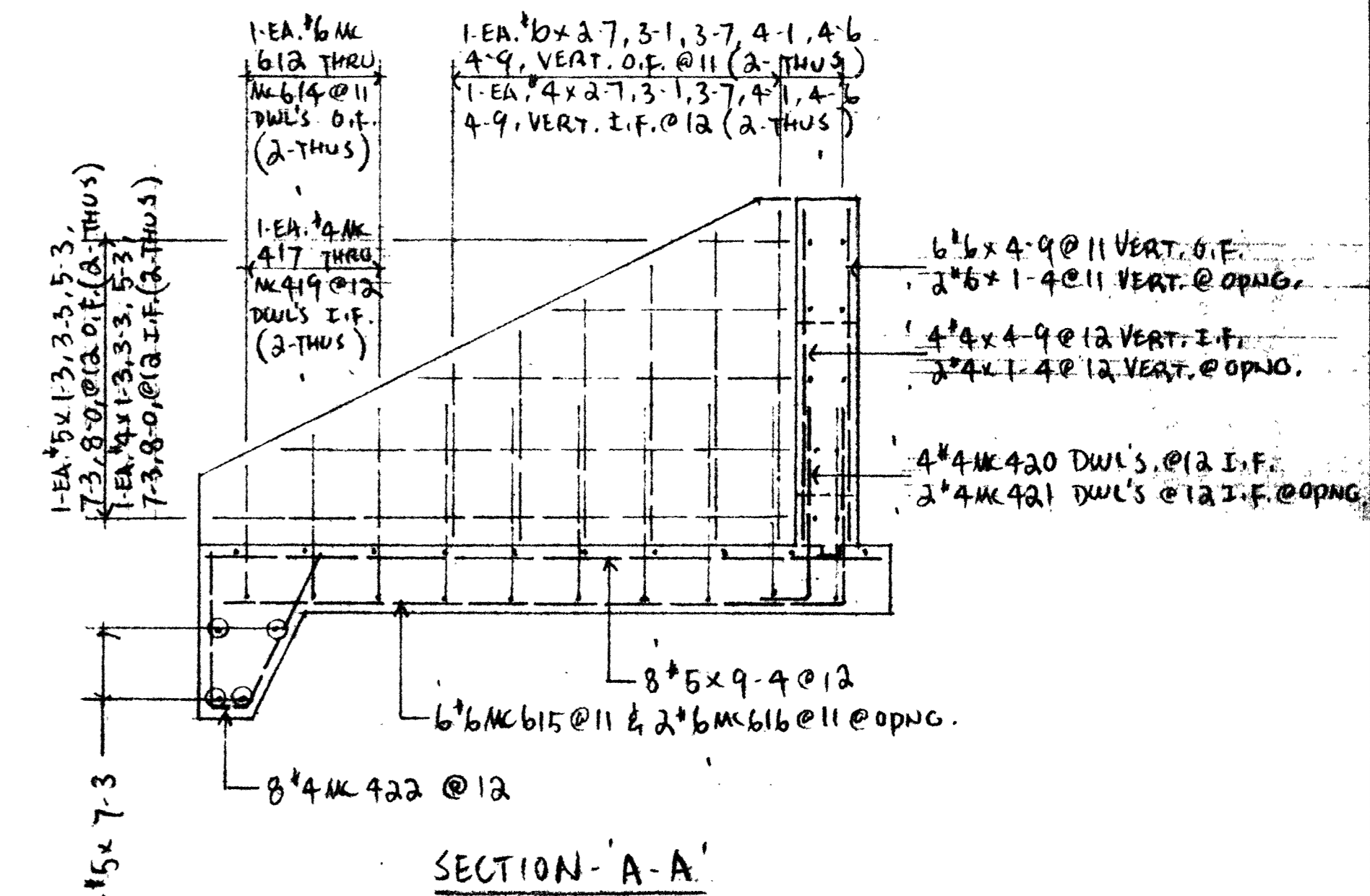

SECTION - A-A

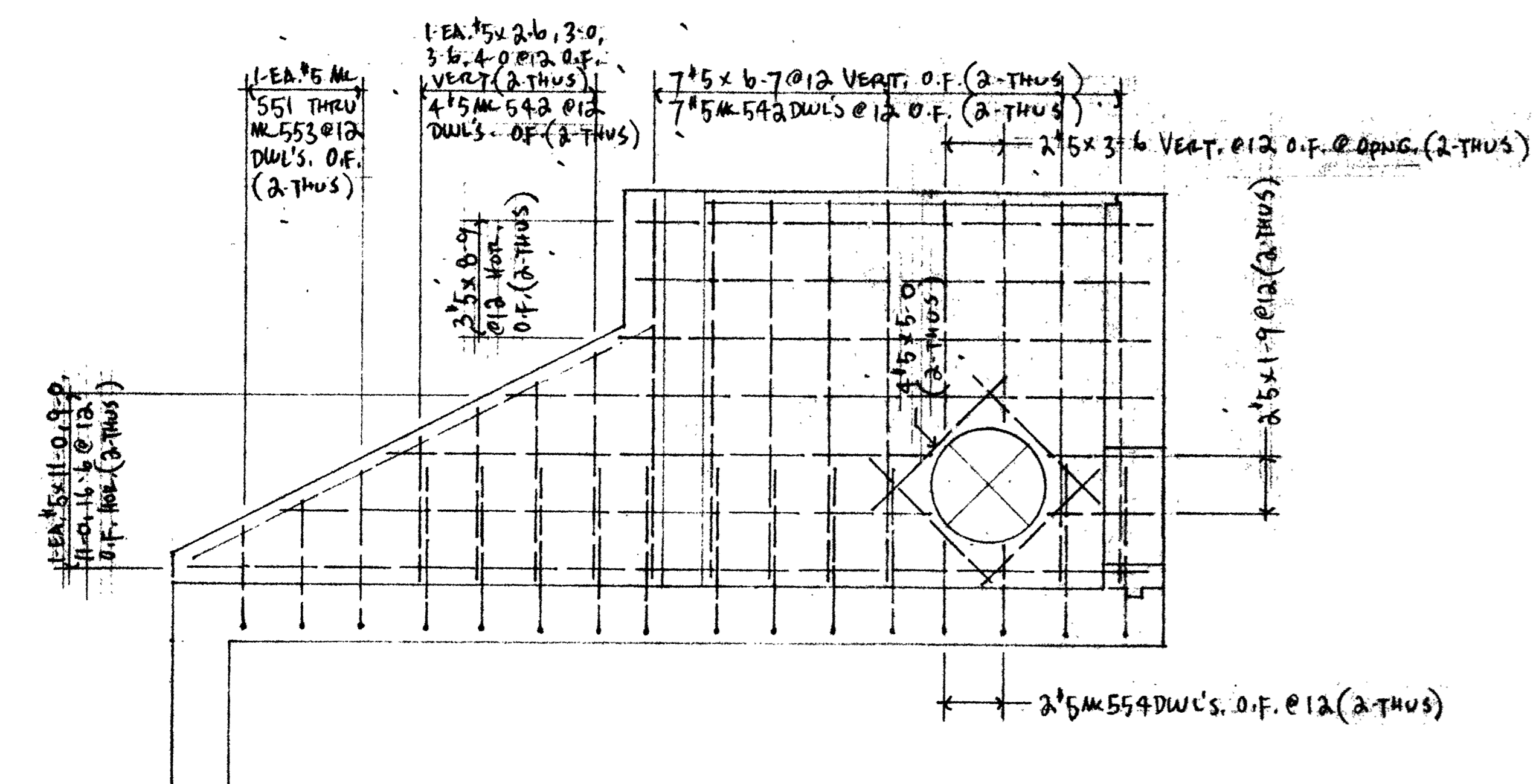

SECTION - B-B

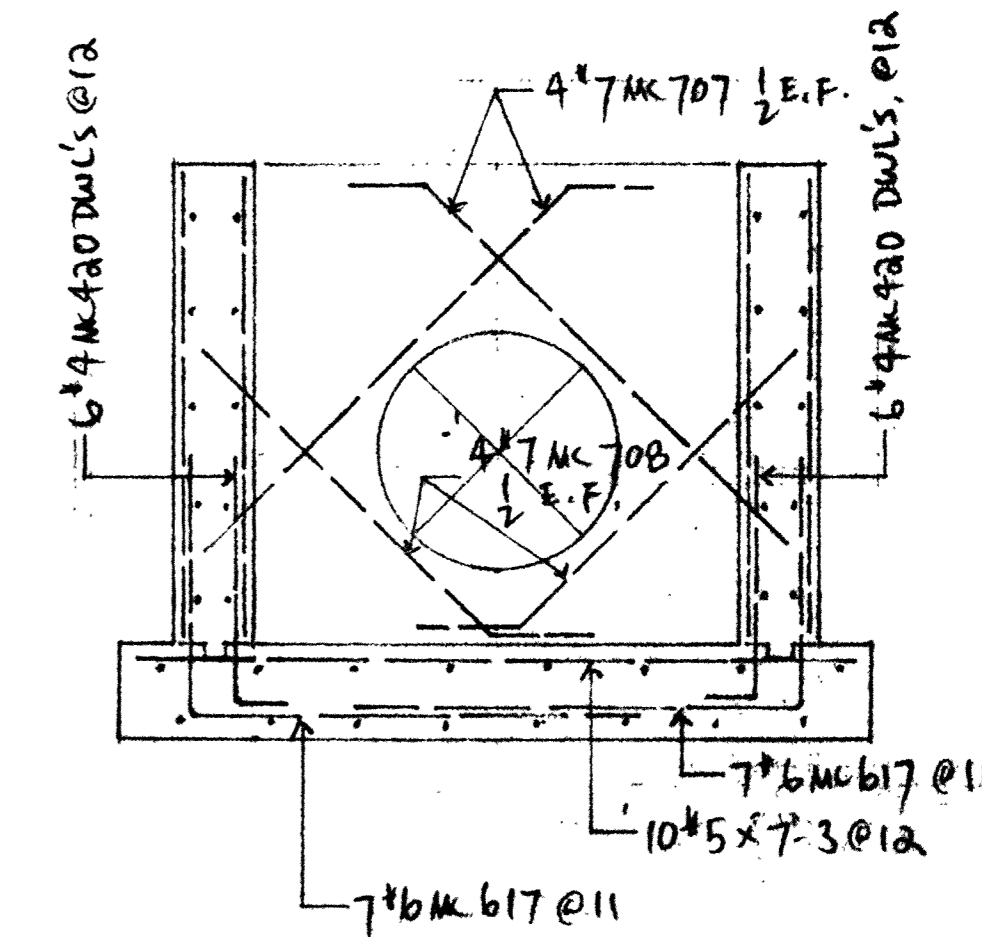
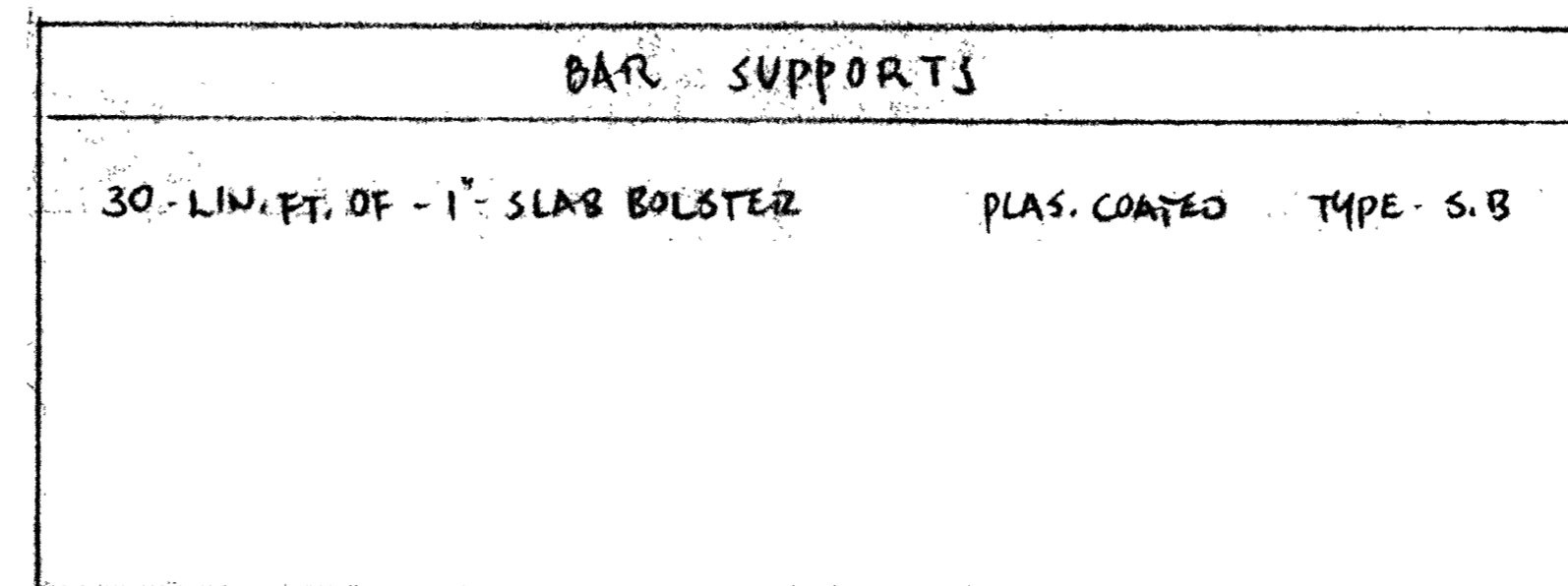

SECTION - B-B

Rehabilit Construction, Inc.
P.O. Box 190
Cape Girardeau, Mo. 63701

PROJECT: Stinson Power Sta. 76-076
CONTRACT # 33
SPEC. REF. 38-1C
DATE RECEIVED: 11-1-78
CHECKED BY: LB
APPROVED BY: LB

THIS DRAWING TO BE USED FOR PLACING REINFORCING STEEL ONLY

ARMCO Fabricated Reinforcing Sales Armco Steel Corporation 7500 East 129th Street Kansas City, Missouri 64128		CONTRACTOR PENZEL CONST. CO. INC. P.O. BOX 329 JACKSON, MO. 63755
ARCH. ENGR. BURNS & McDONNELL	SKESTON POWER STATION UNIT NO. 1 CONTRACT # 33 SITE PREPARATION II	
PROJECT: <u>Stinson Power Sta. 76-076</u> CONTRACT # <u>33</u> SPEC. REF. <u>38-1C</u> DATE RECEIVED: <u>11-1-78</u> CHECKED BY: <u>LB</u> APPROVED BY: <u>LB</u>	FLY ASH POND OVERFLOW STRUCTURE, FLY ASH POND OVERFLOW MONITORING STRUCTURE & HEADWALL	SPLICES: 30-DIA. GR. 40 (MIN.) " " " 42-DIA. GR. 60 (MIN.) TIES, STR. & 3-GR. 40 - ALL OTHERS - GR. 60
REVISION: <u>A</u> DATE: <u>12-13-78</u> DRN. BY: <u>H. J. RAO</u> CHK. BY: <u>M. M. B.</u> DATE: <u>10-6-79</u>	DRAWING NUMBER R-7	SHEET LIST <u>23, 24, 25</u> 3211, UP14, KL 2080

PROJECT 760761	
CONTRACT 33	
DATE JUNE 5, 1978	
DESIGNED WILLIAMS	
DETAILED BEAUNE	
CHECKED RAIDL	

NO.	DATE	BY	REVISION
8-31-78	JAA		ISSUED AS BID
6-4-82	RGP		CONFORMED TO CONSTRUCTION RECORDS

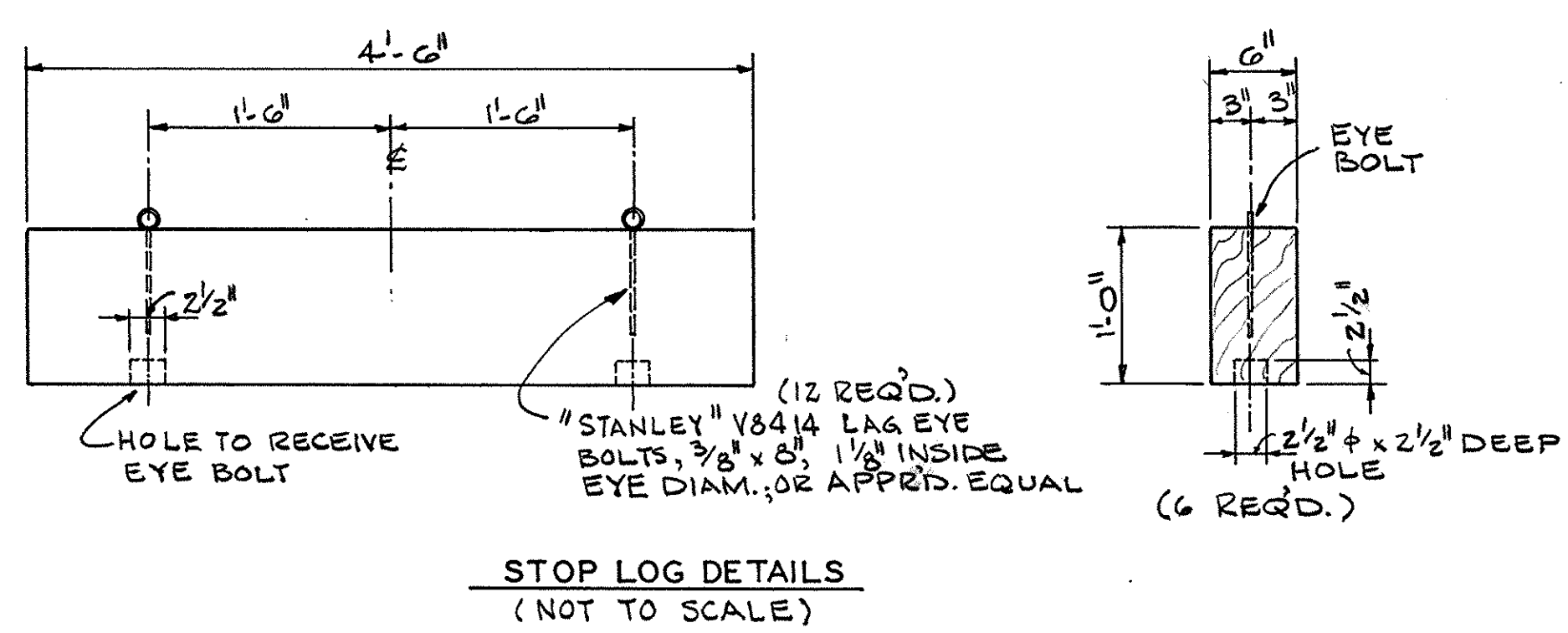
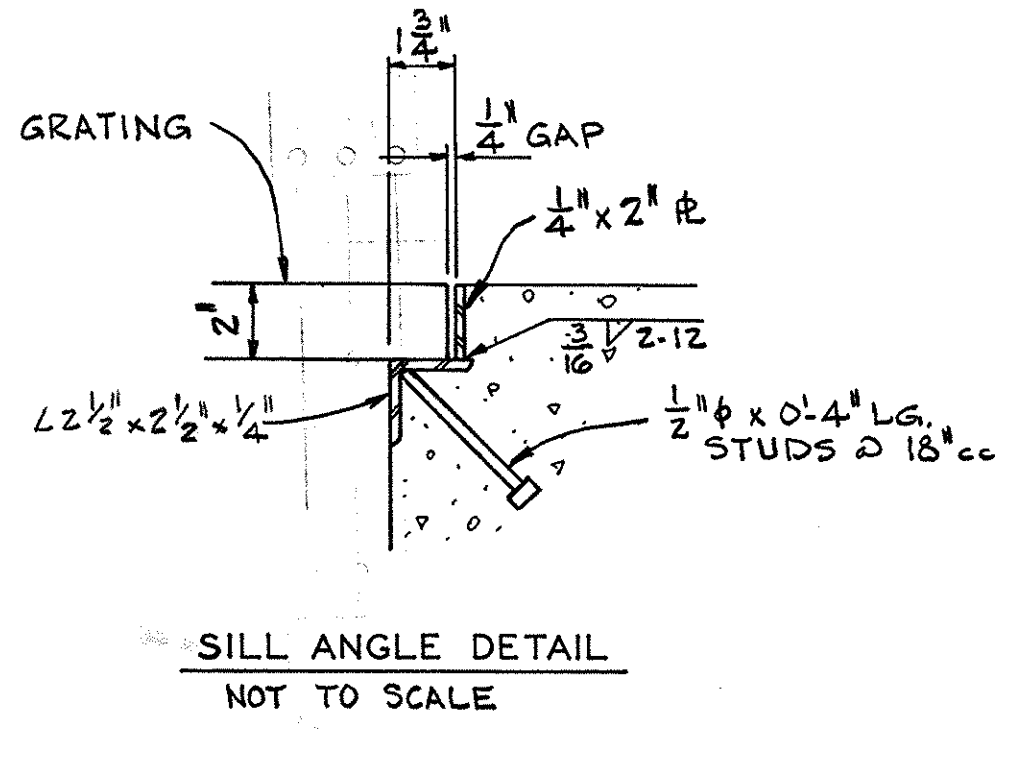
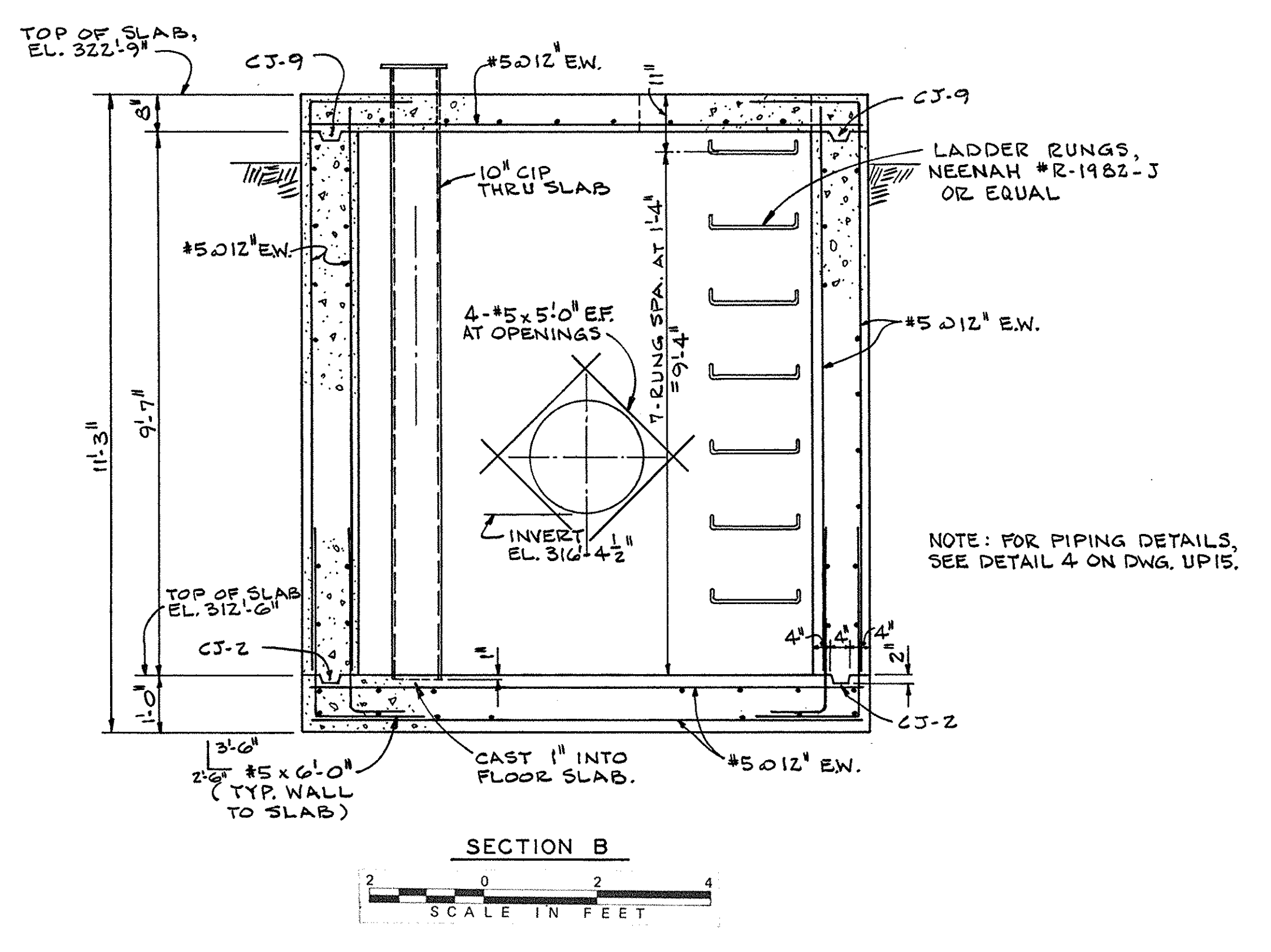
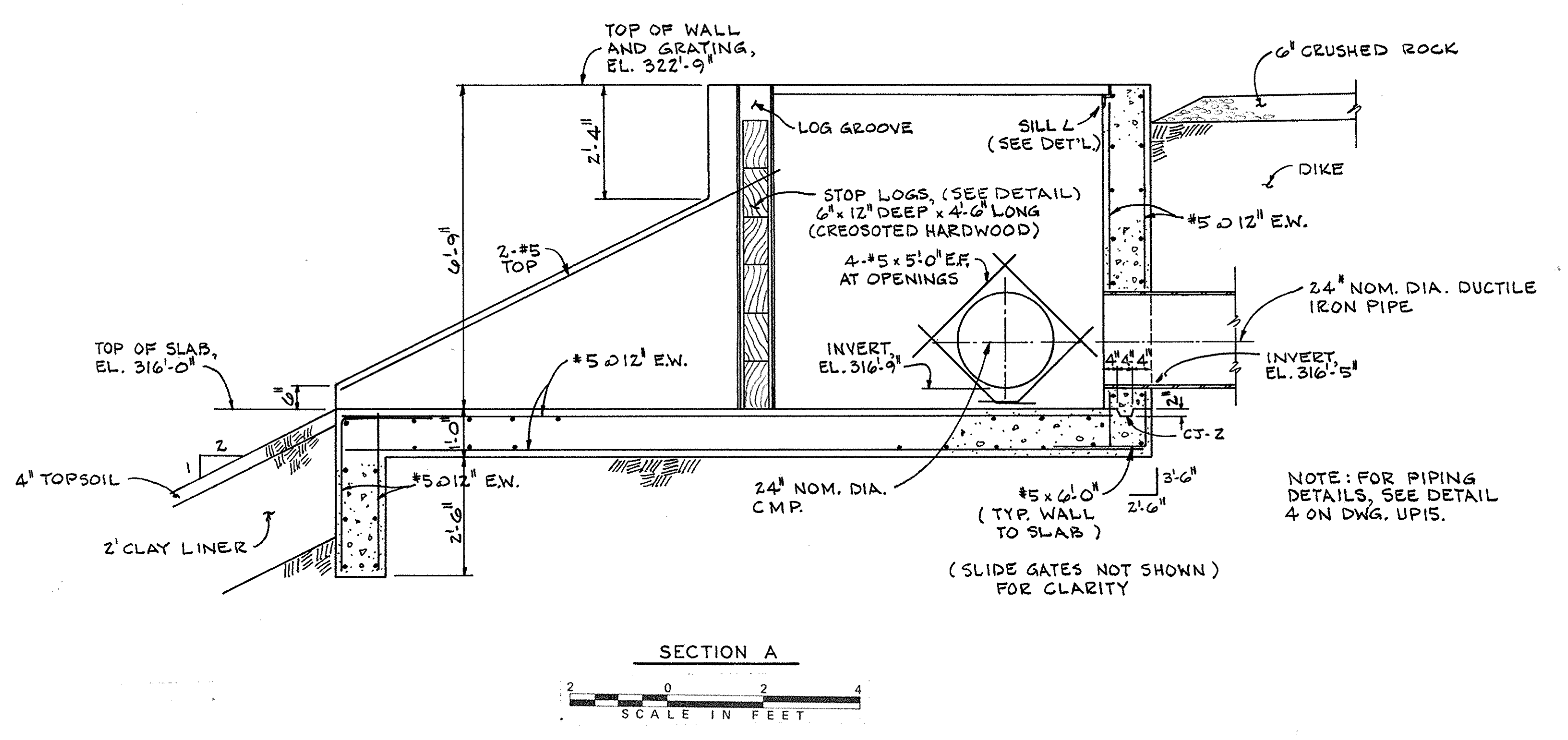
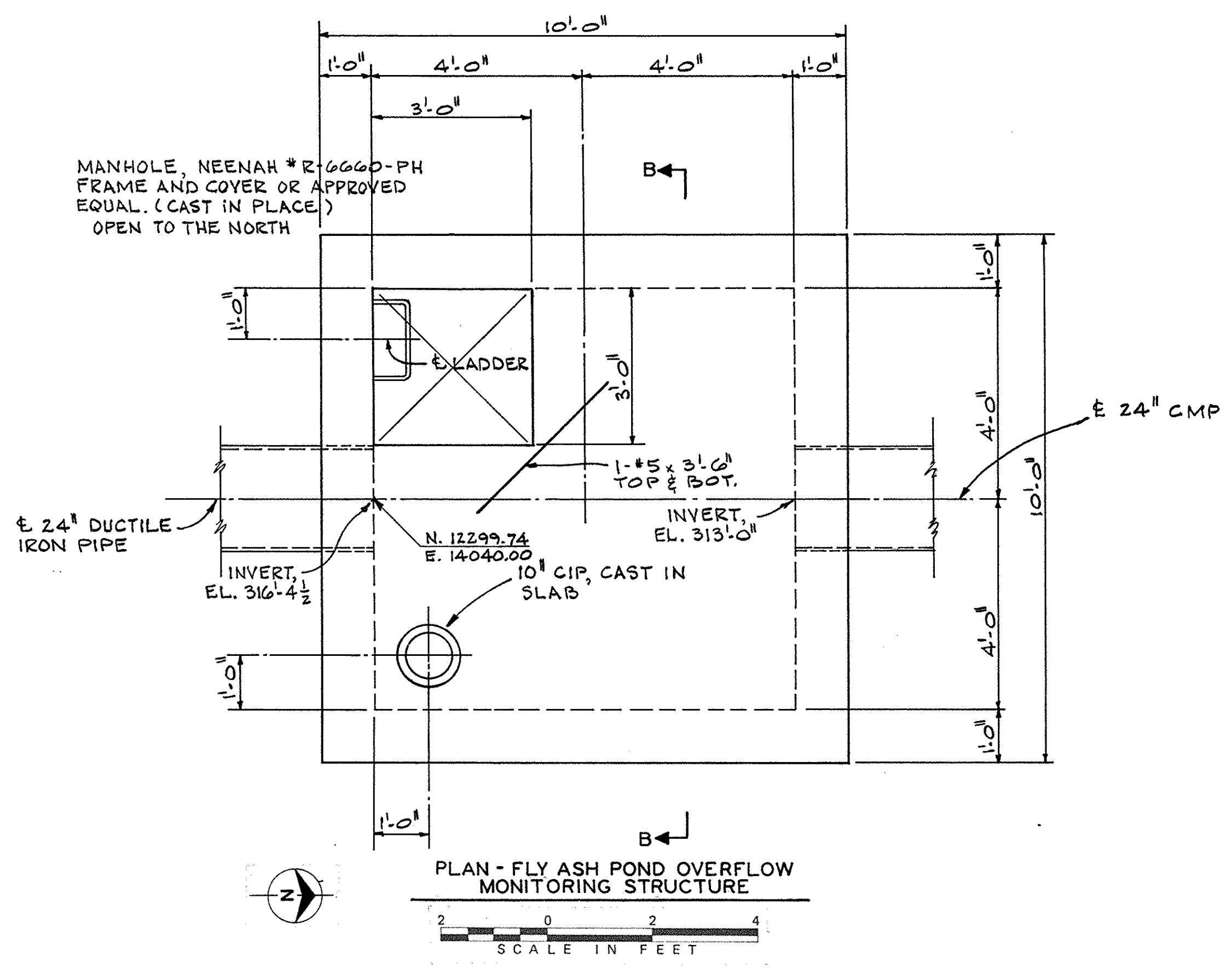
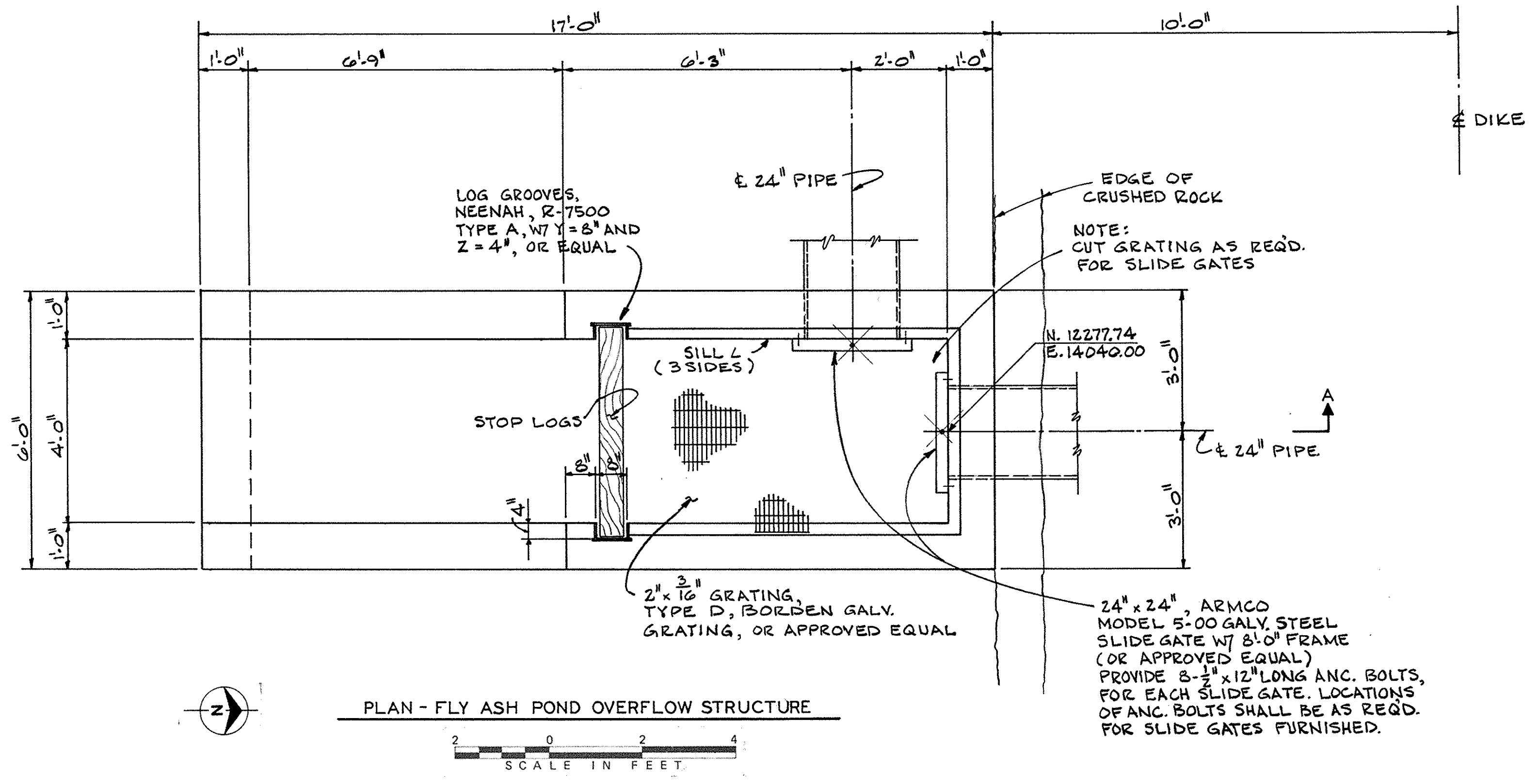

Scale in Centimeter

Scale in Inches

A
B
C
D
E
F
G
H
I
J
K
L
M
N

SITE PREPARATION 2
FLY ASH POND OVERFLOW STRUCTURE

**SIKESTON POWER STATION
UNIT NO. 1**
BOARD OF MUNICIPAL UTILITIES

PHELPS HOGLAND & PHILLIPS
Engineering Company

BURNS & McDONNELL
Engineers-Architects-Consultants

DRAWING NO.	SHEET	OF	SHEETS	REV.
S211				

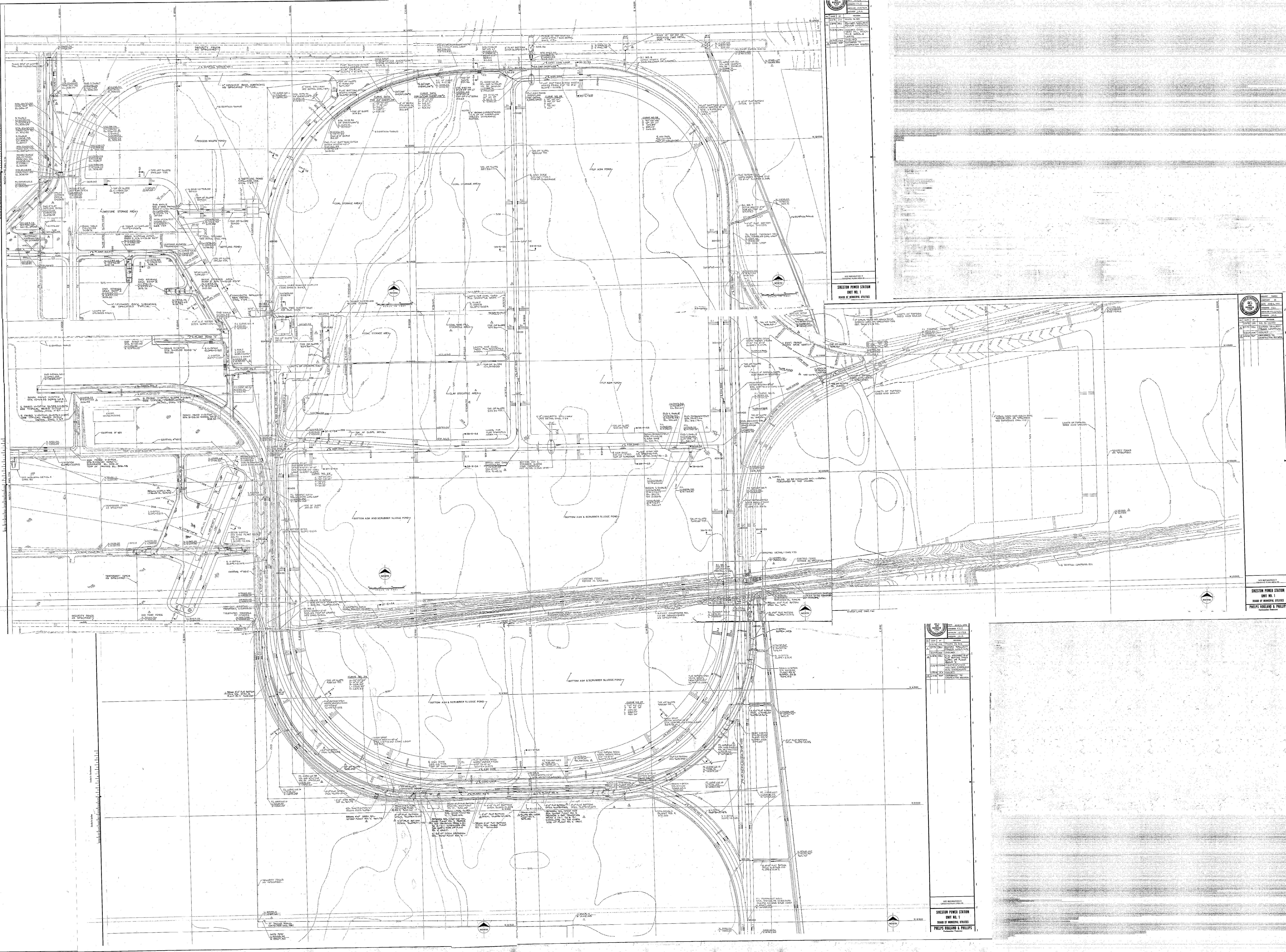

SHEKTON POWER STATION
 UNIT NO. 1
 PLAN OF WINDMILL POND

SHEKTON POWER STATION
 UNIT NO. 1
 PLAN OF WINDMILL POND

SHEKTON POWER STATION
 UNIT NO. 1
 PLAN OF WINDMILL POND

SHEKTON POWER STATION
 UNIT NO. 1
 PLAN OF WINDMILL POND

SHEKTON POWER STATION
 UNIT NO. 1
 PLAN OF WINDMILL POND

PROJECT 760761
 CONTRACT 33
 DATE JUNE 5, 1978
 DESIGNED PETERSEN
 DETAILED ARMSTRONG
 CHECKED JTC

NO.	DATE	BY	REVISION
1	8-31-78	JAA	ISSUED AS BID
2	6-14-82	RGP	CONFORMED TO CONSTRUCTION RECORDS

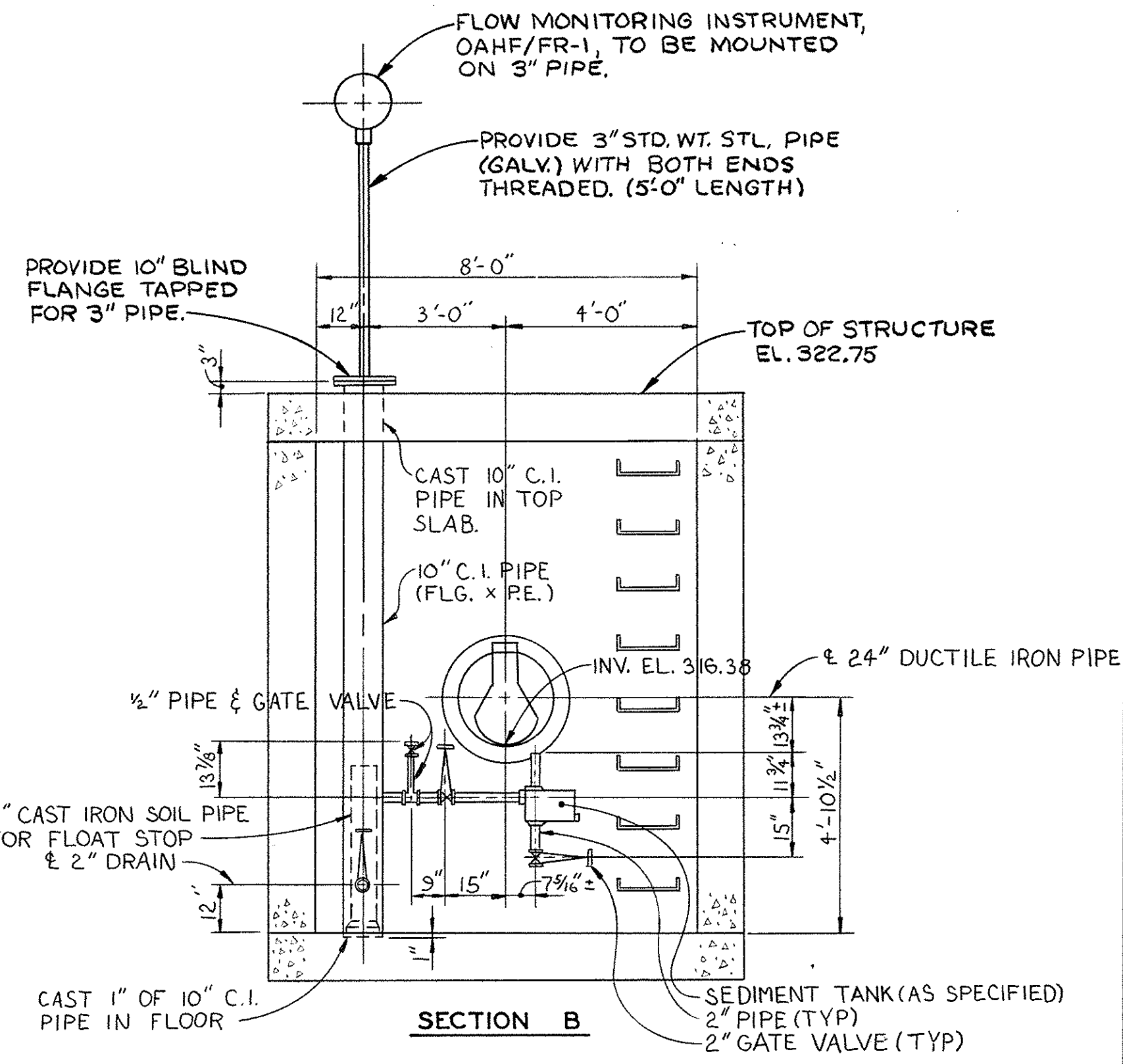
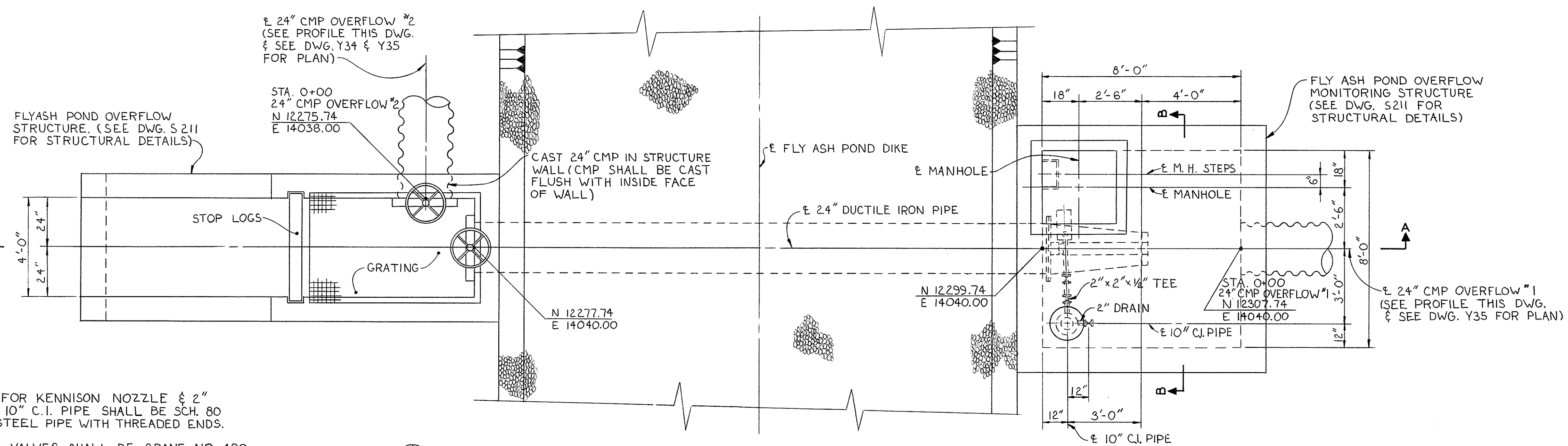

- NOTES:
- 2" x 1/2" PIPE FOR KENNISON NOZZLE & 2" DRAIN FROM 10" C.I. PIPE SHALL BE SCH. 80 GALVANIZED STEEL PIPE WITH THREADED ENDS.
 - 2" x 1/2" GATE VALVES SHALL BE CRANE NO. 490, CLAMP GATE VALVE WITH IRON BODY & BRONZE TRIMMED, OR APPROVED EQUAL.
 - PROVIDE 2-2" TAPPED CONNECTIONS IN THE 10" C.I. PIPE FOR THE 2" PIPE FROM THE KENNISON NOZZLE & THE 2" DRAIN.
 - PROVIDE 3'-4" LENGTH OF 6" CAST IRON SOIL PIPE FOR FLOAT STOP. INSTALL 6" CAST IRON SOIL PIPE INSIDE OF 10" C.I. PIPE WITH BELL DOWN & SETTING ON THE FLOOR OF MONITORING STRUCTURE.
 - NOZZLE SUPPORT ASSEMBLY SHALL BE GALVANIZED. CONTRACTOR SHALL ANCHOR NOZZLE SUPPORT TO FLOOR OF STRUCTURE WITH 4-3/8" CONCRETE ANCHORS.
 - CMP FOR OVERFLOW #1 AND OVERFLOW #2 SHALL BE 16 GA.

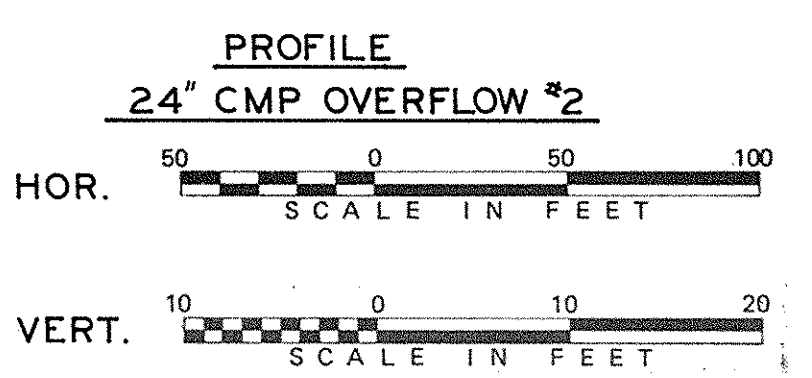
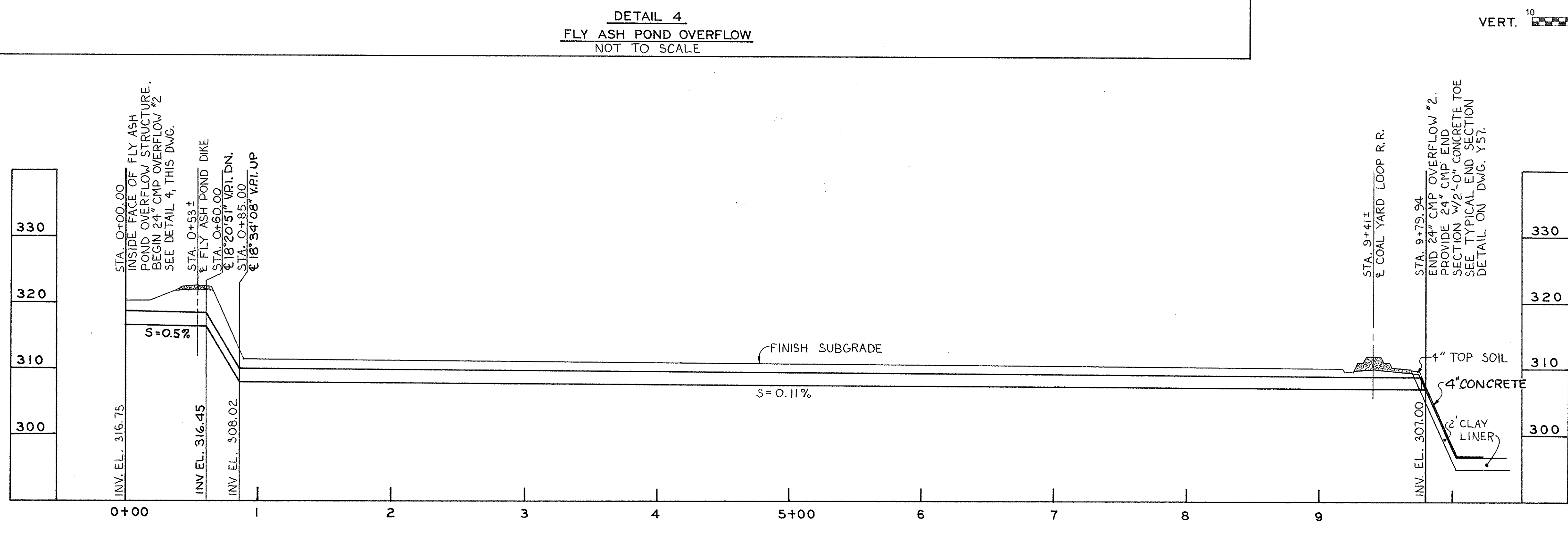
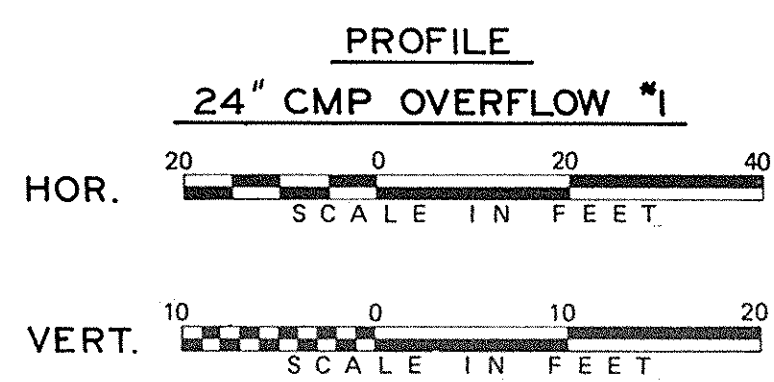
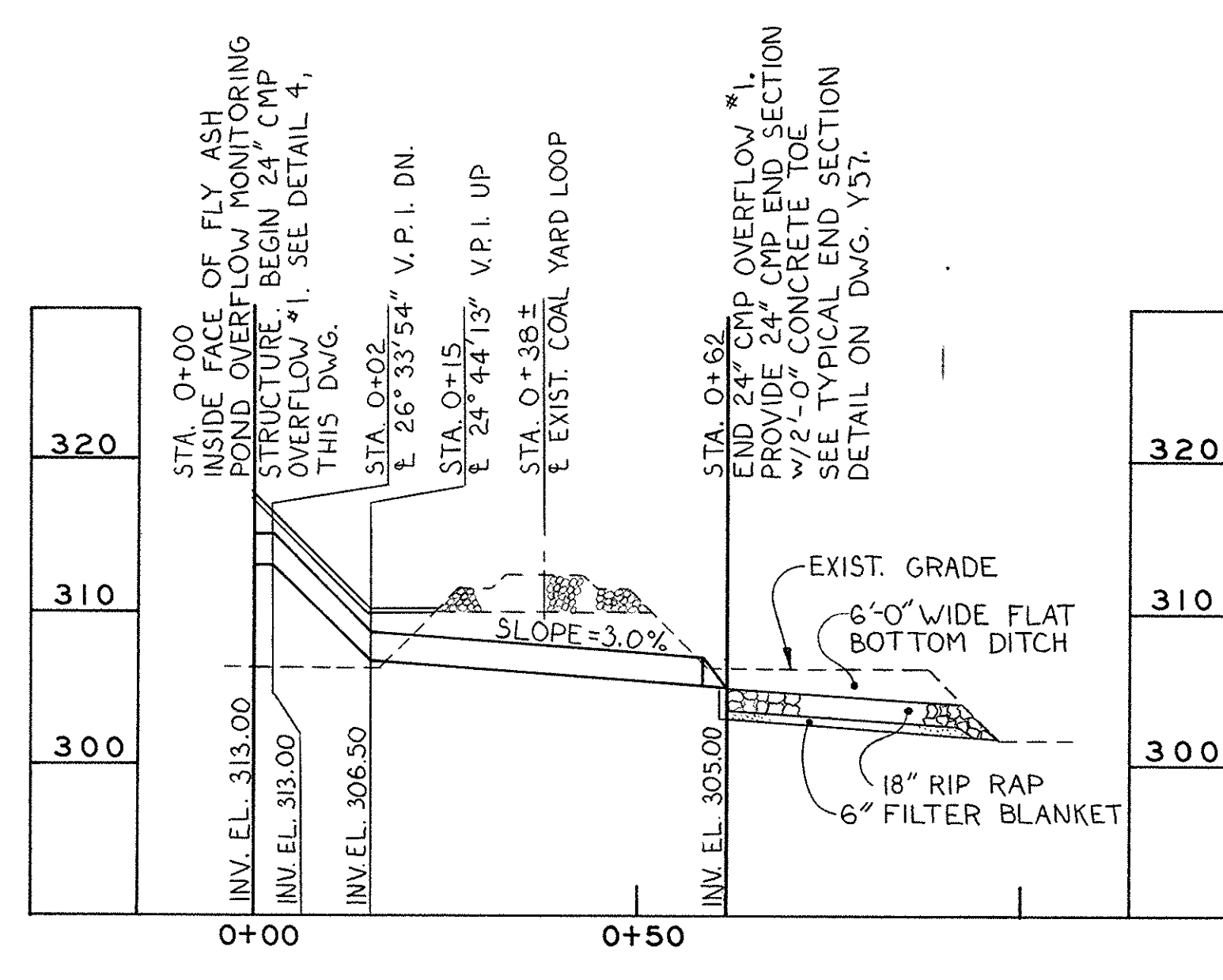
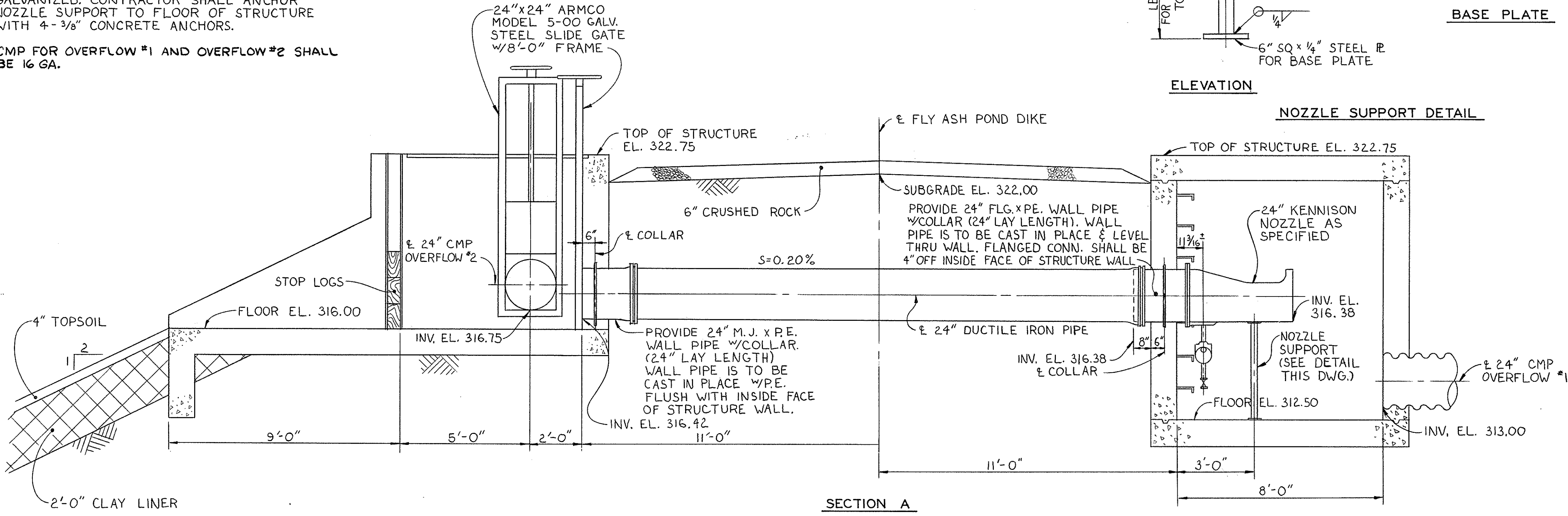
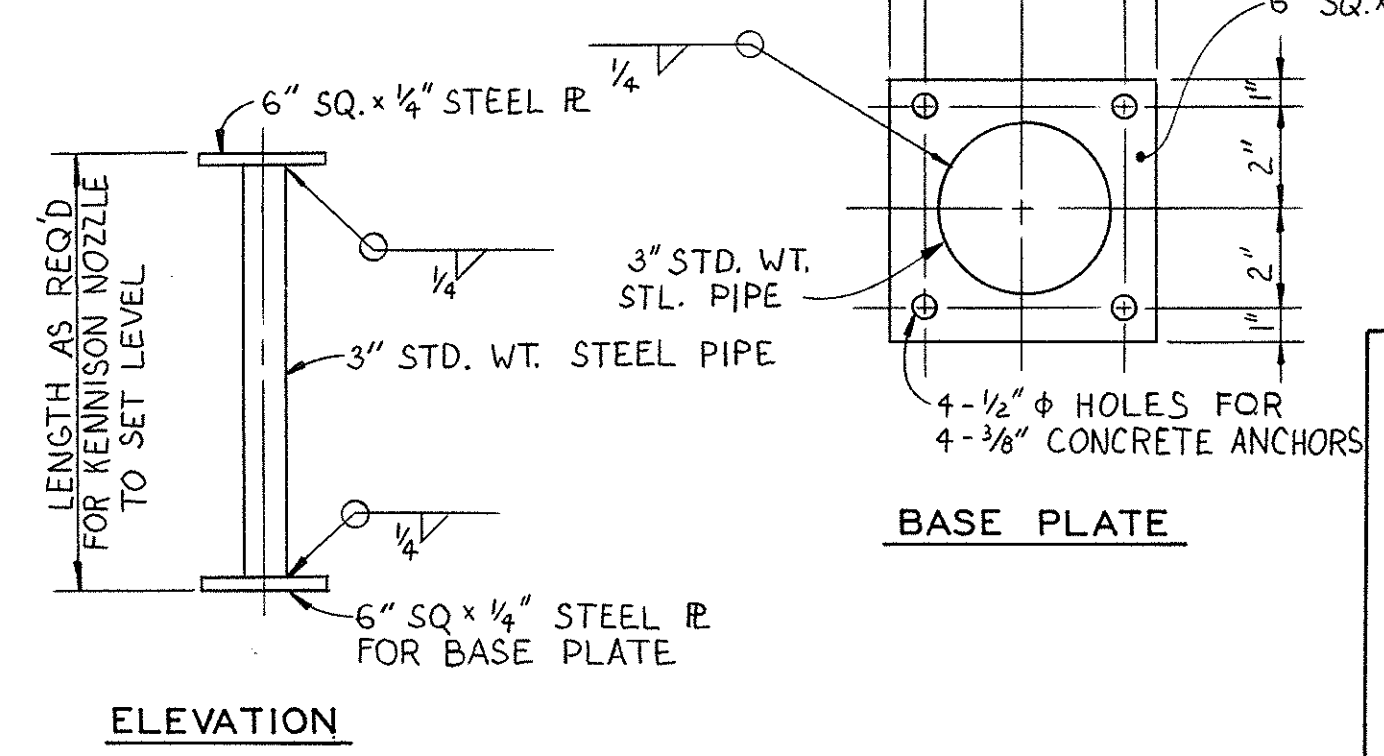

Scale in Centimeter

Scale in Inches

A
B
C
D
E
F
G
H
I
J
K
L
M
N

SITE PREPARATION 2
YARD PIPING DETAILS II

SIKESTON POWER STATION
 UNIT NO. 1
 BOARD OF MUNICIPAL UTILITIES

PHELPS HOGLAND & PHILLIPS
 Engineering Company

BURNS & McDONNELL
 Engineers-Architects-Consultants

DRAWING NO. SHEET OF SHEETS REV.

UP15

STORM SEWER SCHEDULE											
LINE NO.	LENGTH	INVERT ELEV.		INVERT COORDINATES		SLOPE FT./FT.	CMP		RCP		REMARKS
		LOWER	UPPER	LOWER	UPPER		SIZE	GAGE	SIZE	CLASS	
SS-14	106'	298.71	298.98	N 11878.45 E 11904.00	N 11773.09 E 11904.00	.0025	24	16	24	III	STA. 20+71.90 MAIN ENTRANCE ROAD
SS-15	62'	299.70	299.95	N 11591.19 E 11904.60	N 11529.19 E 11904.00	.0040	24	16	24	III	STA. 1+89.00 PLANT ROAD 'F'
SS-16A	31'	307.50	307.75	N 11299.00 E 12878.92	N 11299.00 E 12908.08	.0080	35x24	12			STA. 93+01.58 COAL LOOP
SS-16B	31'	307.50	307.75	N 11293.00 E 12878.92	N 11293.00 E 12908.08	.0080	35x24	12			STA. 93+07.58 COAL LOOP
SS-16C	31'	307.50	307.75	N 11287.00 E 12878.92	N 11287.00 E 12908.08	.0080	35x24	12			STA. 93+13.58 COAL LOOP
SS-16D	31'	307.50	307.75	N 11281.00 E 12878.92	N 11281.00 E 12908.08	.0080	35x24	12			STA. 93+19.58 COAL LOOP
SS-17	62'	307.38	307.58	N 11157.00 E 12691.53	N 11096.00 E 12691.00	.0032	24	16	24	IV	STA. 0+27.73 PLANT ROAD 'G'
SS-18	42'	307.91	308.00	N 10958.00 E 12697.00	N 10958.00 E 12738.73	.0020	15	16	15	IV	STA. 14+23.15 PLANT ROAD 'F'
SS-20	46'	305.58	305.83	N 10441.50 E 12475.00	N 10441.50 E 12521.00	.0054	18	16	18	III	STA. 1+56.00 PLANT ROAD 'B'
SS-21	45'	302.53	302.73	N 10248.50 E 12818.56	N 10248.50 E 12863.04	.0044	18	16	18	V	STA. 4+37.82 PLANT ROAD 'D'
SS-22	58'	297.80	298.55	N 9841.68 E 12822.60	N 9795.00 E 12822.60	.0129	24	16	24	III	STA. 0+33.21 PLANT ROAD 'K'
SS-23	40'	300.65	300.75	N 9049.09 E 12459.00	N 9086.47 E 12459.00	.0056	21	16	21	IV	STA. 10+80.29 PLANT ROAD 'K'
SS-24	84'	302.88	303.17	N 9448.00 E 14931.24	N 9438.00 E 14847.50	.0035	18	14			STA. 44+31.90 MISSOURI PACIFIC ACCESS SPUR WEST
SS-25	36'	303.79	304.69	N 9670.30 E 14967.07	N 9671.69 E 14930.97	.025	18	16	18	V	STA. 28+92.00 PLANT ROAD 'K'
SS-26	62'	302.69	303.44	N 8768.00 E 14931.62	N 8768.00 E 14869.88	.0121	24	14			STA. 37+61.90 MISSOURI PACIFIC ACCESS SPUR WEST
SS-27	61'	302.13	302.39	N 8000.00 E 14927.00	N 8000.00 E 14866.00	.0043	36	14			STA. 29+33.02 MISSOURI PACIFIC ACCESS SPUR WEST
SS-28	83'	298.33	298.53	N 7778.20 E 15226.05	N 7861.16 E 15228.57	.0024	14	14			STA. 26+80.00 MISSOURI PACIFIC ACCESS SPUR EAST
SS-29	44'	303.63	303.97	N 9091.56 E 13980.00	N 9134.74 E 13980.00	.0078	24	14			STA. 12+62.20 COAL LOOP
SS-30	42'	303.52	303.97	N 11644.81 E 14923.95	N 11630.70 E 14884.75	.0012	24	14			STA. 61+39.95 COAL LOOP
SS-31	90'	302.29	302.74	N 12401.18 E 14451.48	N 12311.42 E 14451.48	.0050	24	14			STA. 70+37.80 COAL LOOP
SS-32	22'	297.30	297.41	N 7280.15 E 14071.24	N 7301.05 E 14064.36	.0050	30	14			STA. 18+09.63 MISSOURI PACIFIC ACCESS SPUR WEST
SS-33	38'	307.55	307.65	N 10678.05 E 15275.67	N 10913.75 E 15262.64	.0026	18	14			STA. 7+89.97 SIDING NO. 3
SS-34	22'	300.20	300.31	N 7257.39 E 14035.55	N 7278.29 E 14028.67	.0050	30	14			STA. 17+67.30 MISSOURI PACIFIC ACCESS SPUR WEST
SS-35	9'	305.45	305.50	N 10588.15 E 11745.00	N 10597.15 E 11745.00	.0056	36	14	36"	III	STA. 0+30.00 PLANT ROAD 'C'
SS-36	39'	302.44	302.51	N 7750.08 E 14799.48	N 7715.33 E 14781.52	.0013	24	16	24"	III	STA. 27+00 MISSOURI PACIFIC ACCESS SPUR WEST
SS-37	74'	299.60	299.80	N 10662.80 E 11644.00	N 10662.80 E 11644.00	.0027	21	16			
TSS-4	46'	305.50	305.75	N 11335.00 E 12870.00	N 11335.00 E 12915.50	.0054	36"	14			STA. 92+65.58 COAL LOOP
TSS-5	41'	305.05	305.25	N 11755.69 E 12700.00	N 11714.71 E 12700.00	.0049	36"	16	36"	III	
TSS-6	80'	300.39	302.00	N 11887.64 E 12011.58	N 11887.64 E 12091.68	.020	36"	14			STA. 19+94.92 SIDING NO. 1

DROP INLET SCHEDULE											
D. I. NO.	COORDINATES		DIMENSIONS			TOP ELEV.	OUTLET ELEV.	DRAINAGE GRATE NO.	ELBOW	TYPE	REMARKS
	NORTH	EAST	W	L	H						
D.I.-4	9861.92	12911.46				308.43				III*	STA. 107+38.66 COAL LOOP
D.I.-5	9136.80	13980.00	2'-0"	1'-4 1/4"	4'-4 3/4"	308.43	303.97	ARMCO NO. 1001233	90°	II	STA. 122+62.20 COAL LOOP
D.I.-6	10036.76	14881.54				308.50		ARMCO NO. R-6510-52 TYPE Y		IV**	STA. 137+76.59 COAL LOOP
D.I.-7	11630.00	14882.81	2'-0"	1'-4 1/4"	4'-4 3/4"	308.43	303.97	ARMCO NO. 1001233	90°	II	STA. 61+39.95 COAL LOOP
D.I.-8	12309.36	14451.48	2'-0"	2'-7 1/2"	5'-8 1/4"	308.43	302.74	ARMCO NO. 1001233	90°	II	STA. 70+37.80 COAL LOOP

* FOR TYPE III DROP INLET SEE DETAIL 206-C-208 ON DWG. 5206
 ** TYPE IV DROP INLET IS CAST IN TOP OF CONCRETE STORM SEWER. SEE DWG. 5206

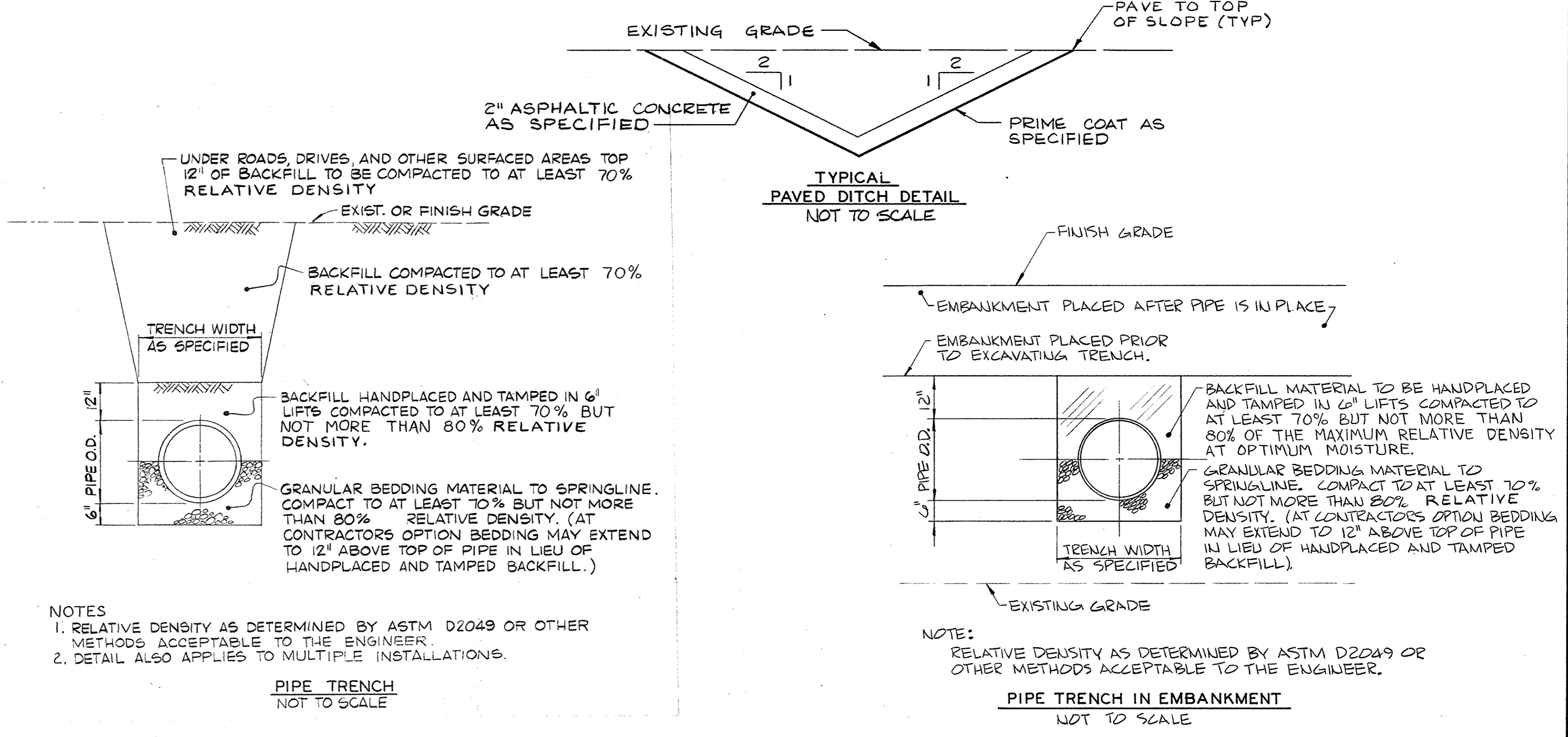

Scale in Centimeter

Scale in Inches

* SEE BULKHEAD DETAIL DWG. Y59
 ** SEE CMP EXTENSION DETAIL DWG. Y59
 *** SEE DROP INLET DETAIL (TYPE II) THIS DWG.
 NOTE: RCP MAY BE SUBSTITUTED FOR CMP AT CONTRACTOR'S OPTION WHERE INDICATED IN SCHEDULE.

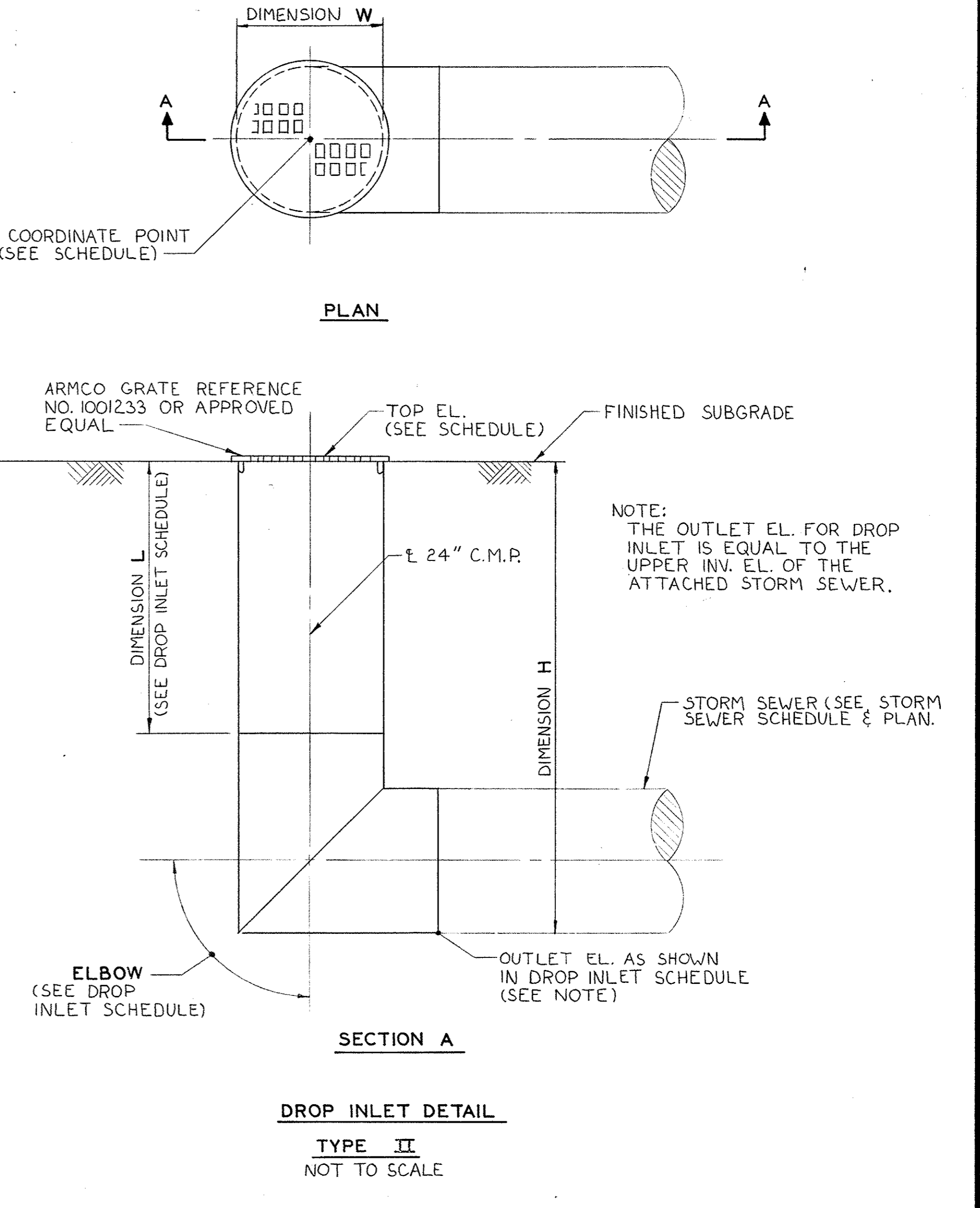
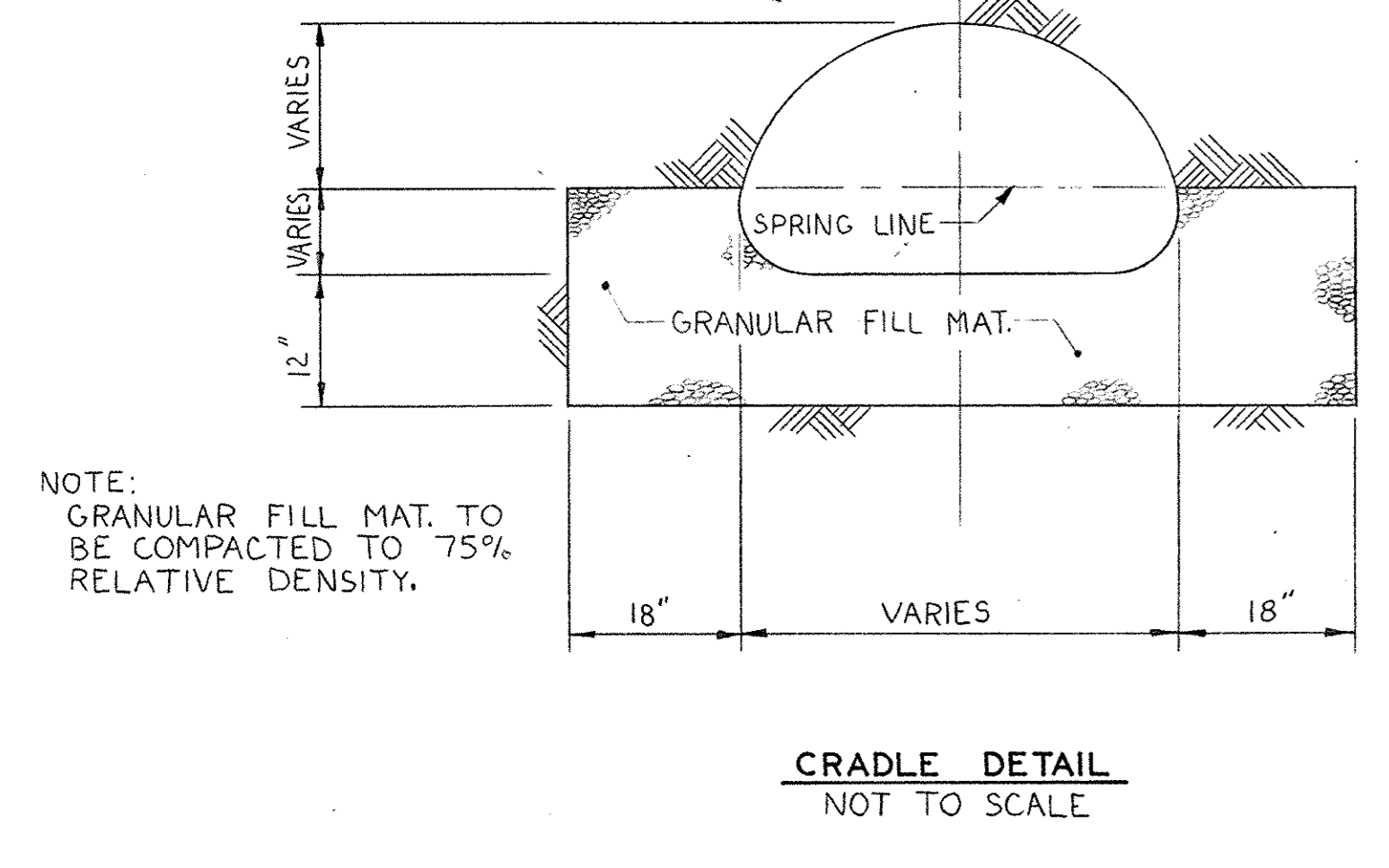
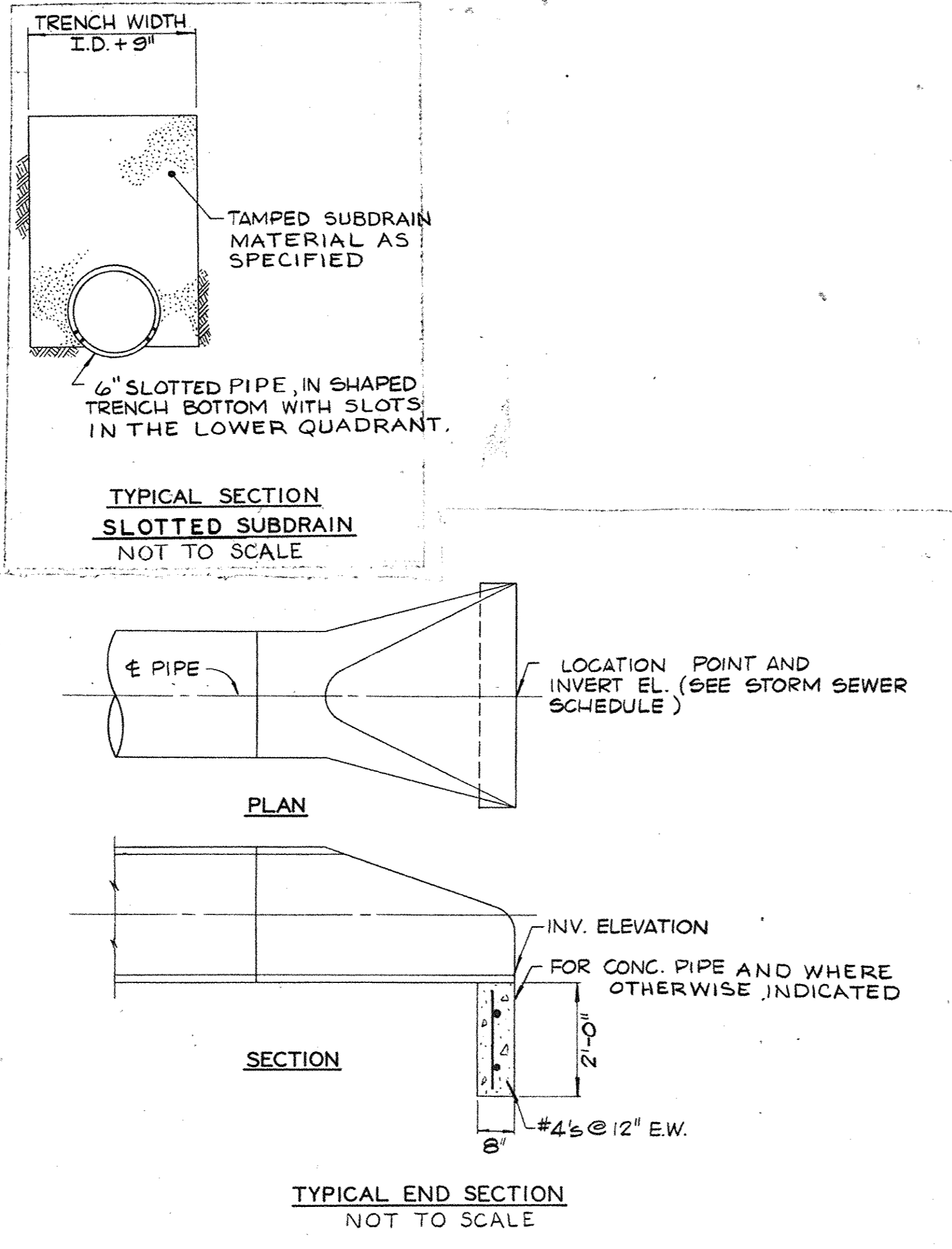

PROJECT 760761
 CONTRACT 33
 DATE JUNE 5, 1978
 DESIGNED KILE
 DETAILED WILCOXON
 CHECKED JAA

NO.	DATE	BY	REVISION
8-21-78	JAA		ISSUED AS BID
2-27-79	DEJ		(4-2) ADDED 55-37 PER FROM NO. 2
3-27-79	JAA		ISSUED
5-21-79	DEJ		(6-4) REVISED LOCATION OF 21" 55-23
5-29-79	FOBA		(4-1)(4-8) REVISED STORM SEWER SCHEDULE FOR TSS-6
5-29-79	JAA		ISSUED
6-14-82	RGP		CONFORMED TO CONSTRUCTION RECORDS

SITE PREPARATION 2
 STORM DRAINAGE DETAILS

**SIKESTON POWER STATION
 UNIT NO. 1**

BOARD OF MUNICIPAL UTILITIES

PHELPS HOGLAND & PHILLIPS
 Engineering Company

BURNS & McDONNELL
 Engineers-Architects-Consultants

DRAWING NO. SHEET OF SHEETS REV.
 Y57 3

APPENDIX C

Historical Construction Specification

TABLE OF CONTENTS

LEGAL NOTICE

INVITATION TO BID

INSTRUCTIONS TO BIDDERS

IB-1 INTRODUCTORY INFORMATION

- A. Terms Defined
- B. Qualification of Bidders
- C. Familiarization With the Work
- D. Subcontractors
- E. Use of Specified Equipment and Materials
- F. Interpretation of Contract Documents to Prospective Bidders
- G. Information to Manufacturer's District Office

IB-2 LABOR-RELATED REGULATIONS

- A. Equal Employment Opportunity (L-RR)
- B. Wage Rate Stipulations (L-RR)
- C. Wage Rate Determinations (L-RR)

IB-3 SITE CONDITIONS

- A. Familiarization with the Site
- B. Subsurface Information
- C. Access to Site

IB-4 INDIRECT COSTS

- A. Taxes
- B. Governmental Fees
- C. Royalties
- D. Tests and Inspections
- E. Utilities

IB-5 COMPLETION TIME

IB-6 THE BID

- A. Method of Bidding
- B. Schedule of Unit Prices for Increased or Decreased Work
- C. Preparation of the Bid
- D. Manufacturers' Data Submitted with Bid
- E. Bid Security
- F. Submission of Bid
- G. Modification or Withdrawal of Bids

IB-7 AWARD OF CONTRACT

- A. Bases of Award
- B. Evaluation of Bids
- C. Notice of Award

IB-8 REFUND OF DEPOSIT ON BID DOCUMENTS

IB-9 SPECIAL CONDITIONS

BID BOND

BID FORM

AGREEMENT

PERFORMANCE BOND

LABOR AND MATERIAL PAYMENT BOND

GENERAL CONDITIONS

- GC-1 THE CONTRACT DOCUMENTS
 - A. Included Documents
 - B. Definitions
 - C. Intent of the Contract Documents
 - D. Ownership of Documents

- GC-2 PRELIMINARY MATTERS
 - A. Time to Commence Work
 - B. Time Starts to Run
 - C. Execution of Agreement

- GC-3 SURETY BONDS
- GC-4 INSURANCE
 - A. General
 - B. Forms of Coverage and Limits of Coverage Required
 - 1. Worker's Compensation and Employer's Liability Insurance
 - 2. Comprehensive Automobile Insurance
 - 3. Comprehensive General Liability Insurance
 - 4. Umbrella Policy
 - 5. Owner's Protective Liability Insurance
 - 6. Builders Risk, Transit and Installation Floater Insurance
 - 7. Operating Hazards

- GC-5 SITE CONDITIONS
 - A. Availability of Lands
 - B. Unforeseen Subsurface Conditions
 - C. Position, Gradient, and Alignment

- GC-6 GENERAL RULES OF THE CONTRACT
 - A. Work by Owner and Others
 - B. Legal Restrictions, Permits and Regulations
 - C. Remedies Not Exclusive
 - D. Patents and Royalties

- GC-7 CONTRACTOR'S RESPONSIBILITIES AND RIGHTS
 - A. Supervision
 - B. Duty to Examine and Compare Contract Documents
 - C. Safety and Protection
 - D. Emergencies
 - E. Subcontractors, Suppliers and Manufacturers
 - F. Labor, Equipment, Materials and Workmanship
 - G. Substitute Equipment or Materials
 - H. Submittals
 - I. Construction Records
 - J. Contractor's Right to Stop Work or Terminate Contract
 - K. Indemnification
 - L. Prompt Written Notice of Claim Required

- GC-8 OWNER'S RESPONSIBILITIES AND RIGHTS
 - A. Communications with Contractor
 - B. Owner's Right To Correct or Complete the Work
 - C. Owner's Right to Suspend Work
 - D. Owner's Right to Terminate Contract

- E. Use of Completed Work
- F. Prompt Written Notice of Claim Required

GC-9 ENGINEER'S STATUS DURING PERFORMANCE OF THE WORK

- A. Owner's Consultant
- B. Role as Interpreter
- C. Interpretations by Engineer
- D. Visits to Site
- E. Resident Project Representative
- F. Authority to Disapprove or Reject Defective Work
- G. Limitations on Engineer's Responsibilities
- H. Engineer's Estimates

GC-10 ADDITIONAL, OMITTED, OR CHANGED WORK

- A. Changes in the Work
- B. Changes to the Contract Price
- C. Changes to the Contract Time

GC-11 RULES GOVERNING ACCEPTANCE OF THE WORK

- A. Warranty and Guarantee
- B. Access to the Work
- C. Tests and Inspections
- D. Defective Work
- E. Uncovering Work
- F. Stopping Defective Work in Progress
- G. Removal and Replacement of Rejected Defective Work
- H. Correction or Repair of Defective Work
- I. Acceptance of Defective Work
- J. Correction of Defective Work During the Guarantee Period

GC-12 PAYMENTS AND COMPLETION

- A. Schedule of Values
- B. Partial Payments
- C. Contractor's Warranty of Title
- D. Payments Withheld
- E. Substantial Completion
- F. Final Inspection and Acceptance
- G. Final Payment
- H. Waiver of Claims
- I. Contractor's Continuing Obligation

LABOR-RELATED REGULATIONS

- L-RR-1 EQUAL EMPLOYMENT OPPORTUNITY
- L-RR-2 WAGE RATE STIPULATIONS
- L-RR-3 WAGE RATE DETERMINATIONS

DETAILED SPECIFICATIONS

DIVISION 1 - GENERAL REQUIREMENTS

- 1-1 SUMMARY OF WORK
 - A. Description of Project
 - B. Work Under This Contract
 - C. Other Contracts
 - D. Continuous Service of Existing Facilities

- 1-2 ADMINISTRATIVE MATTERS
 - A. Initial Coordination Submittals
 - B. Initial Coordination Conference
 - C. Work Progress Schedule
 - D. Work Progress Reports
 - E. Coordination Conferences
 - F. Procurement Schedule
 - G. Compliance Submittals
 - H. Transmittal and Review of Compliance Submittals
 - I. Transmittal of Test Reports
 - J. Information to Manufacturer's District Office
 - K. Shipment Schedules
 - L. Contract Price Breakdown
 - M. Copies of Documents

- 1-3 CONSTRUCTION PROCEDURES AND SCHEDULES
 - A. Procedures
 - B. Scheduled Events
 - C. Owner's Use of Completed Work
 - D. Connections to Existing Facilities
 - E. Underground Obstructions

- 1-4 SHIPMENT OF EQUIPMENT AND MATERIALS
 - A. Preparation
 - B. Marking

- 1-5 INFORMATION REGARDING THE SITE
 - A. Availability of Lands
 - B. Available Facilities

- 1-6 OPERATIONS ON THE SITE
 - A. Conduct of Work
 - B. Construction Offices
 - C. Storage of Equipment and Materials
 - D. Receipt and Unloading of Equipment and Materials
Furnished by Others
 - E. Temporary Facilities
 - 1. Electrical Service
 - 2. Water
 - 3. Sanitary Facilities
 - 4. Telephone
 - 5. Gas
 - 6. Heat
 - F. Maintenance and Use of Roadways
 - G. Maintenance of Railroad Service
 - H. Signs
 - I. Fire Protection
 - J. Cleaning Up

- 1-7 STIPULATIONS REGARDING PROPERTY OF OWNER AND OTHERS
 - A. Use of Owner's Equipment
 - B. Dust and Weather Barriers
 - C. Protection of Existing Property

- D. Protection of the Work
- E. Traffic Regulations
- 1-8 MANUFACTURER'S FIELD SERVICES
 - A. Services with Equipment and Materials Furnished Under This Contract
 - B. Placing Equipment in Operation
 - C. Performance Tests
- 1-9 MEASUREMENT AND PAYMENT
- 1-10 LIST OF DRAWINGS

DIVISION 2 - SITE WORK

2A - SITE PREPARATION AND EARTHWORK

2A-1 GENERAL

- A. Description
- B. Quality Assurance
- C. Job Conditions

2A-2 EQUIPMENT AND MATERIALS

- A. Materials
- B. Equipment

2A-3 PERFORMANCE

- A. Clearing and Grubbing
- B. Demolition
- C. Disposal of Debris
- D. Stripping
- E. Sheeting and Bracing
- F. Dewatering
- G. Stockpiling
- H. Compaction
- I. Site Grading
- J. Excavation
- K. Backfilling
- L. Embankment
- M. Subgrade Preparation
- N. Topsoiling
- O. Filter Blanket
- P. Riprap
- Q. Weed Killer
- R. Maintenance and Repair
- S. Clay Liner

2B - STORM DRAINAGE SYSTEM

2B-1 GENERAL

- A. Description
- B. Quality Assurance
- C. Compliance Submittals

2B-2 MATERIALS

- A. Reinforced Concrete
- B. Iron Castings

- C. Corrugated Metal Pipe (CMP)
 - D. Reinforced Concrete Pipe
- 2B-3 PERFORMANCE
- A. Trenching and Backfilling
 - B. Excavation, Filling, and Backfilling for Storm Drainage Structures
 - C. Pipe Installation
 - D. Storm Drainage Structures
 - E. Drainage Pipe Abandonment (CMP)
- 2C - SEEDING
- 2C-1 GENERAL
- A. Description
 - B. Quality Assurance
 - C. Submittals
- 2C-2 MATERIALS
- A. Seed
 - B. Fertilizer
 - C. Mulch
 - D. Erosion Control Netting
- 2C-3 PERFORMANCE
- A. Seedbed
 - B. Fertilizing
 - C. Seeding
 - D. Mulching
 - E. Netting
 - F. Maintenance
 - G. Measurement and Payment
- 2D - TEMPORARY FENCE (Woven and Barbed Wire)
- 2D-1 GENERAL
- A. Description
 - B. Quality Assurance
 - C. Compliance Submittals
- 2D-2 MATERIALS
- A. General
 - B. Steel Line Posts
 - C. Wire Fabric
 - D. Barbed Wire
 - E. Gates and Accessories
 - F. Concrete
- 2D-3 PERFORMANCE
- A. Installation
- 2E - FENCES AND GATES - SECURITY TYPE
- 2E-1 GENERAL
- A. Description
 - B. Quality Assurance
 - C. Submittals

- 2E-2 EQUIPMENT AND MATERIALS
 - A. General
 - B. Fabric
 - C. Posts, Top Rail and Braces
 - D. Barbed Wire
 - E. Gates (Manual-Swing)
 - F. Gates (Motor-Operated)
 - G. Concrete
 - H. Crushed Rock

- 2E-3 PERFORMANCE
 - A. Preparation
 - B. Installation

- 2F - FOUNDATION PILING
 - 2F-1 GENERAL
 - A. Description
 - B. Quality Assurance
 - C. Submittals
 - D. Handling and Field Protection

 - 2F-2 EQUIPMENT AND MATERIALS
 - A. Piles
 - B. Pile Driving Equipment

 - 2F-3 PERFORMANCE
 - A. Driving Procedures
 - B. Penetration and Driving Resistance
 - C. Jetting
 - D. Predrilling
 - E. Heaving
 - F. Cutoff
 - G. Driving Tolerance
 - H. Splicing
 - I. Required Records
 - J. Field Marking and Elevations
 - K. Rejected Piles

 - 2F-4 PAYMENT

- 2G - SUBDRAIN
 - 2G-1 GENERAL
 - A. Description
 - B. Quality Assurance
 - C. Compliance Submittals

 - 2G-2 MATERIALS
 - A. Slot-Perforated Polyvinyl Chloride (PVC)
 - B. Subdrain Material

 - 2G-3 PERFORMANCE
 - A. Trenching and Backfilling
 - B. Subdrain Material Placement
 - C. Pipe Installation

DIVISION 3 - CONCRETE

3A - FORMS

3A-1 GENERAL

- A. Description
- B. Quality Assurance

3A-2 EQUIPMENT AND MATERIALS

- A. Materials For Facing
- B. Form Ties
- C. Chamfer Strips

3A-3 PERFORMANCE

- A. Form Construction
- B. Time in Place for Forms
- C. Removal of Forms

3B - STEEL REINFORCEMENT

3B-1 GENERAL

- A. Description
- B. Quality Assurance
- C. Submittals
- D. Delivery, Storage and Handling
- E. Testing

3B-2 EQUIPMENT AND MATERIALS

- A. Reinforcement Bars, Ties and Stirrups
- B. Welded Wire Fabric
- C. Bolsters, Chairs and Accessores
- D. Precast Concrete Block Bar Supports

3B-3 PERFORMANCE

- A. Placement of Steel Reinforcement

3C - CONCRETE

3C-1 GENERAL

- A. Description
- B. Quality Assurance
- C. Submittals
- D. Delivery, Storage and Handling

3C-2 EQUIPMENT AND MATERIALS

- A. Composition of Concrete
- B. Concrete Materials
- C. Laboratory Testing of Materials for Use in Concrete
- D. Concrete Qualities Required
- E. Concrete Mix Proportions
- F. Measurement of Materials
- G. Mixing of Concrete
- H. Grout
- I. Concrete Accessories

3C-3 PERFORMANCE

- A. Field Testing
- B. Low-Strength Concrete
- C. Hot-Weather Concreting
- D. Cold-Weather Concreting
- E. Placing of Concrete

- F. Curling of Concrete
- G. Joints
- H. Openings and Inserts in Concrete
- I. Finishes
- J. Defective Surfaces
- K. Equipment Bases

3D - PRECAST CONCRETE BRIDGE UNITS

3D-1 GENERAL

- A. Description
- B. Quality Assurance
- C. Compliance Submittals
- D. Delivery, Storage and Handling

3D-2 MATERIALS

- A. Concrete
- B. Reinforcement

3D-3 PERFORMANCE

- A. Fabrication
- B. Erection

3E - PRESTRESSED, PRECAST CONCRETE BRIDGE GIRDERS

3E-1 GENERAL

- A. Description
- B. Quality Assurance
- C. Compliance Submittals
- D. Delivery, Storage and Handling

3E-2 MATERIALS

- A. Concrete
- B. Reinforcement

3E-3 PERFORMANCE

- A. Fabrication
- B. Erection

DIVISION 4 - NOT USED

DIVISION 5 - METALS: STRUCTURAL AND MISCELLANEOUS

5A - STEEL

5A-1 GENERAL

- A. Description
- B. Quality Assurance
- C. Submittals
- D. Delivery, Storage and Handling

5A-2 MATERIALS

- A. General
- B. Steel Fabrication
- C. Column Base and Equipment Anchor Bolts
- D. Handrail
- E. Edge Angles and Plates
- F. Kick Plates
- G. Steel Floor Grating
- H. Concrete and Masonry Anchors

- 5A-3 PERFORMANCE
 - A. Preparation
 - B. Steel Erection

DIVISION 6 - NOT USED

DIVISION 7 - NOT USED

DIVISION 8 - NOT USED

DIVISION 9 - NOT USED

DIVISION 10 - NOT USED

DIVISION 11 - NOT USED

DIVISION 12 - NOT USED

DIVISION 13 - NOT USED

DIVISION 14 - NOT USED

DIVISION 15 - NOT USED

DIVISION 16 - NOT USED

DIVISION 17 - YARD PIPING

17A - GENERAL REQUIREMENTS

17A-1 GENERAL

- A. Description
- B. Quality Assurance

17A-2 EQUIPMENT AND MATERIALS

- A. Piping and Other Material

17A-3 PERFORMANCE

- A. Field Measurements
- B. Installation
- C. Connections

17B - WALL PIPING FOR COOLING TOWER BASIN

17B-1 GENERAL

- A. Description
- B. Quality Assurance
- C. Submittals

17B-2 EQUIPMENT AND MATERIALS

- A. Steel Pipe
- B. ABS Coupling
- C. Ductile Iron Wall Pipe

17B-3 PERFORMANCE

- A. Installation

17C - SANITARY SEWER SYSTEMS AND STORAGE POND OVERFLOW SYSTEMS

17C-1 GENERAL

- A. Description
- B. Quality Assurance

- C. Submittals
 - D. Delivery and Handling
- 17C-2 EQUIPMENT AND MATERIALS
- A. General Requirements
 - B. Relocation Pipe
 - C. ABS Pipe
 - D. Corrugated Metal Pipe
 - E. Ductile-Iron Pipe
 - F. Manholes
 - G. Slide Gates
 - H. Fly Ash Pond Overflow Measurement
- 17C-3 PERFORMANCE
- A. Installation
- 17D - POTABLE WATER
- 17D-1 GENERAL
- A. Description
 - B. Quality Assurance
 - C. Submittals
- 17D-2 EQUIPMENT AND MATERIALS
- A. Steel Pipe
 - B. Gate Valve
 - C. Valve Boxes
 - D. Gaskets and Boltings Materials
- 17D-3 PERFORMANCE
- A. Installation
- 17E - PIPE INSTALLATION
- 17E-1 GENERAL
- A. Description
 - B. Quality Assurance
 - C. Handling
- 17E-2 EQUIPMENT AND MATERIALS
- A. Equipment and Materials
- 17E-3 PERFORMANCE
- A. Pipe Inspection and Repair
 - B. Cleaning
 - C. Laying
 - D. Protective Field Coatings
 - E. Excavation, Trenching, Bedding and Backfilling
 - F. Relocation of Existing Sanitary Sewer System
 - G. Installation of Potable Water Piping for Guard House
- 17F - FIELD TESTING
- 17F-1 GENERAL
- A. Description
- 17F-2 EQUIPMENT AND MATERIALS
- A. General
 - B. Water

17F-3 PERFORMANCE

- A. General
- B. Special Requirements
- C. Hydrostatic Testing
- D. Air Tests
- E. Repairs

DIVISION 18 - ROADS AND DRIVE SURFACING

18A - CRUSHED ROCK SURFACE COURSE

18A-1 GENERAL

- A. Description
- B. Quality Assurance
- C. Compliance Submittals

- 18A-2 EQUIPMENT AND MATERIAL
 - A. General
 - B. Aggregate
 - C. Equipment

- 18A-3 PERFORMANCE
 - A. General Requirements
 - B. Placing, Shaping and Compaction of Material
 - C. Maintenance
 - D. Waybills and Delivery Tickets

- 18B - BITUMINOUS TACK COAT
 - 18B-1 GENERAL
 - A. Description
 - B. Quality Assurance
 - C. Submittals

 - 18B-2 EQUIPMENT AND MATERIALS
 - A. Equipment
 - B. Material

 - 18B-3 PERFORMANCE
 - A. Preparation of Surface
 - B. Application of Bituminous Tack Coat

- 18C - BITUMINOUS PRIME COAT
 - 18C-1 GENERAL
 - A. Description
 - B. Quality Assurance
 - C. Submittals

 - 18C-2 EQUIPMENT AND MATERIALS
 - A. Equipment
 - B. Materials

 - 18C-3 PERFORMANCE
 - A. Preparation of Surface
 - B. Application of Bituminous Prime Coat

- 18D - HOT-MIX ASPHALTIC CONCRETE PAVEMENT
 - 18D-1 GENERAL
 - A. Description
 - B. Quality Assurance
 - C. Submittals
 - D. Job Conditions

 - 18D-2 EQUIPMENT AND MATERIALS
 - A. Equipment
 - B. Materials
 - C. Mixes

 - 18D-3 PERFORMANCE
 - A. Preparation of Mixture
 - B. Transportation of Mixture

- C. Placing Mixture
- D. Compaction of Mixtures
- E. Joints
- F. Protection of Pavement
- G. Surface Smoothness
- H. Density
- I. Field Laboratory
- J. Waybills and Delivery Tickets

18E - GUARDRAIL

GENERAL CONDITIONS

GC-1 THE CONTRACT DOCUMENTS:

A. Included Documents:

1. Bid Documents:
 - a. Legal Notice and Invitation to Bid - INV.
 - b. Instructions to Bidders - IB.
 - c. Bid Bond.
 - d. Bid Form - B.
 - e. Agreement - A.
 - f. Performance Bond.
 - g. Labor and Material Payment Bond.
 - h. General Conditions - GC.
 - i. Labor-Related Regulations - L-RR.
 - j. Specifications.
 - k. Addenda as may be issued.
2. Contract Drawings.
3. Modifications as may be issued.
4. Manufacturer's data submitted with the Bid.
5. List of Subcontractors, suppliers and manufacturers which have been accepted by Owner.
6. Information to be provided in the form of erection drawings, manufacturer's specifications and similar submittals on equipment and materials furnished by Owner or others under separate contract for installation under this Contract.
7. Compliance Submittals furnished by Contractor and accepted by Engineer.
8. Additional Drawings which may be furnished by Engineer to interpret the Contract Drawings or in connection with a Contract modification.

B. Definitions: Wherever used in these General Conditions or elsewhere in the Contract Documents, the following terms have the meanings indicated below, which are applicable to both the singular and plural thereof:

1. "Addenda" - written changes or interpretations of the Contract Documents issued by Engineer prior to the opening of Bids.
2. "Amendment" - a form issued by the Engineer, signed by the Owner and accepted by the Contractor providing for an addition, deletion, or revision in the Work, or an adjustment in the Contract Price or the Contract Time issued after execution of the Agreement.
3. "Bid" - the formal offer of the Bidder submitted on the prescribed Bid Form together with the required Bid security and all information submitted with the Bid that pertains to performance of the Work.
4. "Bidder" - any person, firm, or corporation submitting a Bid for the Work or their duly authorized representatives.
5. "Bid Documents" - the bound volume containing all of the Contract Documents, except the Contract Drawings, prepared by Engineer to specify the Work and conditions upon which Bids are to be based.
6. "Compliance Submittals" - all drawings, samples, and other items prepared by Contractor, a Subcontractor, manufacturer or supplier, and submitted by Contractor to Engineer as a basis for approval of the use of equipment and materials proposed for incorporation in the Work or needed to describe proper installation, operation and maintenance.

GC-1 THE CONTRACT DOCUMENTS: continued

7. "Contract" - the entire Agreement between Owner and Contractor as evidenced by the Contract Documents.
8. "Contract Documents" - all documents listed in GC-1 A. "Included Documents."
9. "Contract Drawings" - the bound set of drawings prepared by Engineer to indicate the Work upon which Bids are to be based.
10. "Contract Price" - the total monies payable to Contractor under the Contract Documents.
11. "Contract Time" - the number of days or the dates stated in the Contract Documents for the completion of the Work.
12. "Contractor" - the party entering into the Agreement for the performance of the Work or his duly authorized representative.
13. "Date of Contract" - the date set forth at the beginning of the Agreement.
14. "Days" - calendar days of twenty-four (24) hours each measured from midnight to the next midnight.
15. "Drawings" - all Contract Drawings, drawings submitted by Contractor as accepted by Engineer, and all drawings furnished to Contractor during the progress of the Work.
16. "Engineer" or "Engineer-Architect" - Phelps Hogland & Phillips Engineering Company and Burns & McDonnell Engineering Company, Missouri Corporations, or their duly authorized representatives.
17. "Equipment" - all equipment, apparatus, devices and parts thereof required as part of the Work and which may not properly be considered as "materials."
18. "Field Change Memorandum" - a approved by the Owner, issued by the Engineer and accepted by the Contractor providing for an addition, deletion, or revision in the Work, or an adjustemnt in the Contract Price or the Contract Time issued after execution of the Agreement. Field Change Memorandums are incorporated into the Contract by subsequent Amendments.
19. "Law" - law of the place of the Project which shall govern the performance hereunder.
20. "Modification" or "Contract Modification" - a written amendment of the Contract Documents signed by both parties, a written order for a minor change or alteration in the work by Engineer, or a Field Change Memorandum, all accomplished or issued after execution of the Agreement in accordance with the Contract Documents.
21. "Notice of Award" - the written notice by Owner to the successful Bidder of the acceptance of his Bid.
22. "Notice to Commence Work at the Site" - the written notice of Engineer stipulating the date on which Contractor may occupy the site.
23. "Notice to Proceed" - the written notice of Owner stipulating the date on which Contractor may begin work and which marks the start of counting Contract Time.
24. "Owner" - the party for whom the Work is to be performed or his duly authorized representative.
25. "Project" - the part of Owner's improvement program described in Division 1 of the Specifications.
26. "Resident Project Representative" - the authorized representative of Engineer who is assigned to the construction site.

27. "Specifications" - the part of the Contract Documents containing descriptions of the special conditions affecting or related to the Work, and of a technical nature covering the equipment, materials and workmanship required in the Work.
28. "Subcontractor" - an individual, firm or corporation having a direct contract with Contractor or with any other Subcontractor for the performance of a part of the Work at the site.
29. "Substantial Completion Date" - the date as determined by Engineer when the Work or a designated part thereof is sufficiently complete in accordance with the Contract Documents so that the Work or designated part thereof can be used for the purposes for which intended.
30. "Work" - any and all obligations, duties, and responsibilities necessary to the successful completion of the Contract assigned to or undertaken by Contractor under the Contract Documents including all bonds, insurance, labor, equipment, materials, submittals, services, and supervision.
31. "Written notice" - shall be deemed to have been duly served when delivered in person to the individual or to a member of the firm or to an officer of the corporation for whom it is intended, or when sent by certified or registered mail to the last business address known to him who gives notice.
32. The words "acceptable," "equivalent," "approved," "reasonable," "satisfactory," "suitable," or like words shall mean acceptable, equivalent, approved, reasonable, satisfactory or suitable in the judgment of Engineer unless specifically stated otherwise.
33. The words "as indicated" refer to the Contract Drawings and "as specified" refer to the other Contract Documents.
34. The terms "responsible" or "responsibility" mean that the party to which the term applies shall perform all activities, pay all costs, and assume all liabilities pertaining thereto.

C. Intent of the Contract Documents:

1. It is the intent of the Contract Documents to provide for the proper and complete performance of the Work.
2. The Contract Documents comprise the entire Agreement between Owner and Contractor. No verbal agreement or conversation with any officer, representative, agent, or employee of Owner or Engineer, either before or after the execution of the Agreement, will affect or modify the terms or obligations herein contained. The Bid Documents and Contract Drawings may be modified only as provided in these General Conditions.
3. The Contract Documents are complementary and what is called for by any one is as binding as if called for by all.
4. The precedence of the Contract Documents is in the following sequence:
 - a. Amendments.
 - b. Field Change Memorandum.
 - c. Basis of contract award letter by the Engineer, if issued and bound in the specifications.
 - d. Addenda or Modifications of any nature prior to award of contract.
 - e. The Specifications where, if there be a conflict, Engineer will determine which stipulation best meets the intent of the design.

GC-1 THE CONTRACT DOCUMENTS: continued

- f. The Drawings, where the precedence shall be Drawings of larger scale over those of smaller, figured dimensions and noted equipment and materials over graphic indications.
 5. Conflicts between Drawings or Specifications and applicable codes and standards will be referred to Engineer for a decision thereon.
 6. In case of any conflict between manufacturers' data and the Bid Documents or Contract Drawings the Bid Documents and Contract Drawings will take precedence unless the manufacturer's data conforms to data submitted with the Bid with a statement that the Bid is conditioned upon furnishing the equipment and materials defined in the manufacturers' data submitted therewith.
 7. Reference to known standards of any technical society, organization, or association or to codes of Local, State, or Federal authorities means the latest edition of such standard, code, or tentative standard or code published and in effect at the date of the Legal Notice and Invitation to Bid, unless specified otherwise.
 8. Applicable codes and standards referenced in these Contract Documents establish minimum requirements for equipment, materials and Work and are superseded by more stringent requirements of Drawings or Specifications when and where they occur.
 9. Materials or work described in words which, so applied, have a well-known technical or trade meaning shall be held to refer to such recognized standards.
 10. Work that may reasonably be inferred from the Specifications or Drawings as being required to produce the intended result shall be supplied whether or not it is specifically called for.
 11. The Specifications are separated into Divisions and Sections for convenience in defining the Work. This sectionalizing is not to be construed as an assignment of labor, equipment or material to any particular craft or trade nor to relieve Contractor of responsibility for the proper coordination and completion of all the Work described, whether performed by Contractor, his Subcontractors, suppliers or manufacturers.
 12. The Contract Documents are governed by the Law of the place of the Project.
- D. Ownership of Documents: All Specifications, Drawings and copies thereof furnished by Engineer shall remain his property. They shall not be used on any extension of this Project or on another project and, with the exception of those sets which have been signed in connection with the execution of the Agreement, shall be returned to him on request upon completion of the Work.

GC-2 PRELIMINARY MATTERS:

A. Time to Commence Work:

1. Upon receipt of Contract Documents fully executed by Owner or Notice to Proceed, Contractor shall immediately proceed with activities pertaining to the Work such as specified initial coordination submittals and conferences.

GC-2 PRELIMINARY MATTERS: continued

2. Contractor shall not move onto the site until Engineer has issued a written Notice to Commence Work at the Site.
 3. Engineer shall issue a written Notice to Commence Work at the Site upon completion of the following:
 - a. Receipt of acceptable copies of insurance policies and certificates.
 - b. The acceptance of specified initial coordination submittals.
 - c. The conclusion of initial coordination conferences.
 4. The Notice to Commence Work at the Site will name the date on which Contractor may move onto the site, which date will be not more than thirty (30) days after the Date of Contract unless Engineer and Contractor agree upon a longer time.
- B. Time Starts to Run: The Contract Time starts to run on the Date stated in the Notice to Proceed.
- C. Execution of Agreement:
1. Engineer will furnish eight (8) copies of the Bid Documents to Contractor each containing an exact copy of the Bid Form as submitted, surety bonds to be properly executed, and Agreement to be signed with the date of his signature.
 2. The prepared copies shall be delivered to Engineer for transmittal to Owner within a reasonable time after the date of Notice of Award.
 3. Owner will sign the Agreement, insert the date of his signature at the beginning of the Agreement, and return two (2) copies to Contractor.

GC-3 SURETY BONDS:

- A. Coincident with the execution of the Agreement, Contractor shall furnish to Engineer a Performance Bond, and a Labor and Material Payment Bond drawn upon the forms included in these Contract Documents.
- B. Bonds shall be executed with the proper sureties, through a company licensed to operate in the State of Missouri, and named on the current list of "Surety Companies Acceptable on Federal Bonds" as published in the Federal Register by the Audit Staff, Bureau of Accounts, Treasury Department.
- C. Bonds shall be signed by an agent resident in the State of Missouri. Date of bonds shall be the same as the date of Contractor's signature on the Agreement.
- D. Performance Bond shall be in the full Contract Price, guaranteeing the faithful performance of the Contract, and otherwise conditioned as required by Law. Labor and Material Payment Bond shall be in the full Contract Price, guaranteeing the payment of all bills and obligations arising from the performance of the Contract, and otherwise conditioned as required by Law.

GC-3 SURETY BONDS: continued

- E. The bonds shall be automatically increased in amount and extended in time without formal and separate amendments to cover full and faithful performance of the Contract in the event of Contract Modifications, regardless of the amount of time or money involved. It is Contractor's responsibility to notify his surety of any changes affecting the general scope of the Work or change in the Contract Price or Time.
- F. At any time during the continuance of the Contract that the surety on any bond becomes unacceptable to Owner for financial reasons, Owner has the right to require additional and sufficient sureties which Contractor shall furnish to the satisfaction of Owner within ten (10) days after notice to do so.

GC-4 INSURANCE:

A. General:

- 1. Contractor or Owner, as specified herein, shall purchase and maintain at his expense, insurance of such types and in such amounts as are specified herein to protect Contractor, Owner, and Engineer, from claims which may arise out of or result from Contractor's operations under the Contract Documents, whether such operations be by Contractor or by any Subcontractor or anyone directly or indirectly employed by Contractor or any Subcontractor or for whose acts Contractor or any Subcontractor may be legally liable.
- 2. Such insurance shall cover claims for damages because of Bodily Injury or death to Contractor's employees including claims brought under:
 - a. Workmen's Compensation Laws.
 - b. Disability Benefit Laws.
 - c. Occupational sickness or disease laws.
 - d. Other similar employee benefit laws.
- 3. Such insurance shall also cover claims for damages because of Personal Injury, Bodily Injury, Sickness, Disease or Death of any person or persons other than Contractor's employees, and claims arising out of destruction of property including loss of use thereof.
- 4. Contractor or Owner, as specified herein, shall also purchase and maintain at his expense all property insurance of such types and in such amounts as are specified herein, to protect Contractor, Owner, and Engineer from loss arising from damage to the Work and equipment and materials to be incorporated in the Work.
- 5. If Contractor requests in writing that any insurance not specified to be furnished by Owner be included in any property insurance specified to be furnished by Owner, Owner may provide such insurance and the cost thereof shall be charged to Contractor by appropriate Contract Modification.
- 6. Failure of Contractor to maintain proper insurance coverage will not relieve him of any contractual responsibility or obligation.
- 7. If part of the Work is to be subcontracted, Contractor shall either cover any and all Subcontractors in his insurance policies or require each Subcontractor not so covered to obtain insurance of the same type and with the same limits as the Contractor is required to carry

hereunder which will protect the Subcontractor, Contractor, Owner, and Engineer against all applicable hazards or risks of loss designated herein.

8. Any payment of an insured loss under policies of property insurance, including but not limited to the insurance required by paragraphs B.6. and B.7. of this article, shall be made payable to Owner as Trustee for the insureds as their interests may appear. Owner, as Trustee, shall have the power to adjust, settle and make payments of such loss to such insureds, subject to all mortgages and other restrictions thereon.
9. Owner and Contractor hereby waive all rights against each other and against Engineer for damages arising out of an insured loss under policies of property insurance, including but not limited to the insurance required by paragraphs B.6. and B.7. of this article. Contractor shall require all Subcontractors to provide a similar waiver in favor of Contractor, Owner, and Engineer.
10. The party responsible hereunder to procure insurance shall provide the other party hereunder a copy of the policy or a certificate of insurance in a form satisfactory to such other party. Such policy or certificate shall provide that thirty (30) days' written notice be given to the other party prior to any material change or cancellation of the insurance. No Work shall be commenced under this Contract until all such policies and certificates have been so provided.
11. In the event the party responsible hereunder to procure insurance shall not procure such insurance within a reasonable time before the risk of loss is scheduled to attach, the other party hereunder may procure such insurance and the party responsible to procure such shall pay the entire cost of such insurance and the cost of procuring such insurance. In the event such other party is damaged by the failure of the party responsible to procure such insurance to actually procure such insurance, the party responsible to procure such insurance shall assume full responsibility for all damages arising out of such failure.

B. Forms of Coverage and Limits of Coverage Required:

1. Worker's Compensation and Employer's Liability Insurance:

- a. Contractor, at his sole expense, shall comply with all requirements of the Worker's Compensation Laws of the States in which work is performed hereunder and shall furnish evidence of such compliance to Owner. Contractor, at his sole expense, agrees to carry Employer's Liability Insurance covering all operations and Work hereunder. All insurance purchased pursuant to this paragraph shall include an "All States" endorsement.
- b. The limits of all insurance purchased pursuant to this paragraph shall be not less than:
 - (1) Workmen's Compensation - Statutory.
 - (2) Employers' Liability - \$1,000,000 each person.

2. Comprehensive Automobile Insurance:

- a. Contractor, at his sole expense, agrees to carry Comprehensive Automobile Insurance covering all vehicles, owned, hired, or non-owned, licensed or not licensed, used in the operations and Work hereunder.

GC-4 INSURANCE: continued

- b. The limits of this insurance shall be not less than:
 - (1) Bodily Injury - \$1,000,000 each person
- \$1,000,000 each occurrence
 - (2) Property Damage - \$1,000,000 each occurrence
- c. Owner and Engineer shall be Named Insureds on this insurance with respect to all claims arising out of the operations or Work hereunder.
- 3. Comprehensive General Liability Insurance:
 - a. Contractor, at his sole expense, agrees to carry Comprehensive General Liability Insurance covering all operations and Work hereunder whether performed by Contractor, Subcontractor or any agent, servant, worker or employee of Contractor or Subcontractor or any other person, firm, or corporation for whose acts Contractor or Subcontractor may be liable.
 - b. This insurance shall include Contractual Liability coverage and shall specifically refer to this Contract and shall specifically cover the liability assumed hereunder by Contractor.
 - c. The property damage liability coverage under this policy shall contain no exclusion (commonly referred to as XC&U exclusion) relative to blasting, explosion, collapse of buildings, or damage to underground property and shall have a broad form endorsement.
 - d. This insurance shall include Independent Contractors Protective Liability coverage.
 - e. This insurance shall include Products and Completed Operations coverage. Contractor shall continue this coverage in full force and effect for a period of at least one (1) year after the date of the final acceptance of the Work hereunder by the Owner.
 - f. This policy shall include Personal Injury liability insurance.
 - g. The limits of this insurance shall be not less than the following:
 - (1) Bodily Injury - \$1,000,000 each occurrence
 - (2) Property Damage - \$1,000,000 each occurrence
- \$1,000,000 aggregate
 - h. Owner and Engineer shall be Named Insureds on this insurance with respect to all claims arising out of the operations or Work hereunder.
- 4. Umbrella Policy: At the option of Contractor, the coverages and minimum limits as required in paragraphs 1, 2 and 3 above may be furnished by use of an "Umbrella Liability Insurance Policy."
- 5. Owner's Protective Liability Insurance:
 - a. Contractor, at his sole expense, shall purchase Owner's Protective Liability Insurance. This insurance shall be maintained in full force and effect for the duration of the Contract, by Contractor and shall name Owner and Engineer as the Named Insureds.
 - b. This insurance shall have the same limits of liability as the Comprehensive General Liability Insurance and shall protect Owner and Engineer against any and all claims and liabilities for injury to or death of persons, or damage to property caused in whole or in part by, or alleged to have been caused in whole or in part by, the negligent acts or omissions of Contractor or Subcontractors or any agent, servant, worker, or employee of Contractor or Subcontractor arising from the operations or Work hereunder.
 - c. This insurance may be provided by endorsement to Contractor's Comprehensive General Liability Insurance policy.

GC-4 INSURANCE: continued

6. Builders Risk, Transit and Installation Floater Insurance:
- a. Builders Risk and Transit and Installation Floater Insurance shall be furnished by Owner. This insurance shall cover the interests of Owner, Engineer, Contract and Subcontractors.
 - b. This insurance shall cover against all risk of direct physical loss of, or damage to, materials, equipment, and structures which are to become a part of the permanent plant, while such property is on the plant site.
 - c. The limits of liability for any one occurrence:
 - (1) \$5,000,000 - Loss of or damage to property in transit.
 - (2) \$50,000,000 - Loss or damage caused by or resulting from earthquake.
 - (3) \$148,724,850 - Loss of or damage to property at the erection site caused by or resulting from all other perils insured against.All loss exceeding these limits shall be of the responsibility of the Contractor or Subcontractor.
 - d. In the event of loss or damage, the following sums shall be deducted:
 - (1) \$100,000 in respect of each loss caused by or arising out of land movement, including but not limited to earthquake, subsidence, differential settlement, landslide or mud flow.
 - (2) \$100,000 in respect of each loss caused by or arising out of water damage, including but not limited to flood, wind driven water, ground water, rainfall and/or resulting runoff.
 - (3) \$100,000 in respect of each loss caused by or arising out of hot testing operations.
 - (4) \$5,000 in respect of each loss caused by or arising out of all other perils insured against.All deductible shall be the responsibility of the Owner unless damage is caused by Contractor's or Subcontractor's negligence.
 - e. This insurance does not cover Contractors', Subcontractors' equipment, machinery, tools, trailers or other enclosures not destined to become part of the permanent plant.
 - f. Contractor shall not remove any of Owner's equipment from the plant site or place equipment in off-site storage, after risk of loss for such equipment has passed to the Owner, unless Contractor provides insurance to cover loss from any cause whatsoever.
7. Operating Hazards: Owner shall provide insurance to cover operating hazards on facilities not otherwise insured hereunder prior to preliminary tests of equipment, wiring and piping which are involved with such risks.

GC-5 SITE CONDITIONS:

A. Availability of Lands:

1. Owner shall make available, as indicated in the Contract Documents and not later than the date when needed by Contractor, the lands upon which the Work is to be done, easements for access thereto, and any other lands designated for the use of Contractor.

GC-5 SITE CONDITIONS: continued

2. Easements for permanent facilities or permanent changes in existing facilities shall be obtained and paid for by Owner unless otherwise specified.
 3. Contractor shall confine his operations to the construction limits indicated and be responsible for obtaining any additional space desired for temporary construction facilities or storage of equipment and materials; or additional easements desired for access.
- B. Unforeseen Subsurface Conditions:
1. Contractor shall promptly notify Engineer in writing of any subsurface or latent physical conditions encountered at the site which differ materially from those specified or indicated, or which could be reasonably interpreted from examination of the site and available subsurface information at the time of bidding.
 2. Engineer will promptly investigate those conditions and advise Owner if further surveys or subsurface tests are necessary. Promptly thereafter, Owner will obtain the necessary additional surveys and tests and furnish copies of results to Engineer and Contractor.
 3. If the Engineer finds that the subsurface or latent physical conditions encountered at the site differ materially from those specified or indicated, or which could have been reasonably interpreted from examination of the site and available subsurface information at the time of bidding, then a contract modification will be issued incorporating the necessary revisions.
- C. Position, Gradient, and Alignment:
1. All Work shall be done to the lines, elevations and grades indicated.
 2. Engineer will furnish a minimum of one (1) bench mark and one (1) base line (or two (2) reference points) to enable Contractor to lay out and properly construct the Work. From the base line and bench mark established by Engineer, Contractor shall complete the layout of the Work and shall be responsible for all measurements that may be required for execution of the Work to the location and limit marks prescribed in the Contract Documents, subject to such modifications as Engineer may require to meet changed conditions in the Work.
 3. All monuments, bench marks, reference points, and stakes established by Engineer shall be carefully preserved; and in case of his destruction of the same, Contractor shall be charged with the resulting expense of replacement and shall be responsible for any mistakes or loss of time that may result from their loss or disturbance.
 4. Contractor shall furnish competent men, equipment, tools, stakes and other materials as required for properly staking out the Work, and shall make such surveys as are required for establishing pay limits and determining quantities for progress pay estimates. He shall furnish Engineer with one (1) copy of all field notes of such surveys.
 5. Contractor shall make all test holes needed to locate existing structures and utilities beneath the ground surface which might interfere with his Work.

GC-5 SITE CONDITIONS: continued

6. Contractor shall call to the attention of Engineer any reference lines, points, or bench marks which may have been disturbed or which seem to be off line or grade.

GC-6 GENERAL RULES OF THE CONTRACT:

A. Work by Owner and Others:

1. Owner reserves the right to perform various activities with its own forces and to let other contracts in connection with the Project. Contractor shall afford Owner and other contractors reasonable opportunity for the introduction and storage of their equipment, materials and construction equipment and the execution of their work, and shall properly connect and coordinate his Work with theirs.
2. If any part of Contractor's Work depends for proper execution or results upon the work of Owner or any other separate contractor, Contractor shall inspect such work immediately upon its completion, or as soon thereafter as it is available to him, and promptly report to Engineer any defect in such work that renders it unsuitable for such proper execution and results. His failure to so inspect and report within ten (10) days after the work is available or not less than thirty (30) days before the scheduled start of any of his Work affected thereby shall constitute an acceptance of Owner's or other contractor's work as fit and proper for the reception of his Work, except as to defects which may develop in such work during or after the execution of Contractor's Work.
3. Wherever work being done by Owner's forces or by other contractors is contiguous to Contractor's Work, the work of each of the various interests involved will be scheduled as agreed in coordination conferences or as determined by the Engineer to secure completion of the various portions of the Project in general harmony.

B. Legal Restrictions, Permits and Regulations:

1. Contractor shall be responsible for all construction licenses, building and other permits, and governmental inspections required by public authorities for performing the Work and which are not specified to be obtained by Owner. Owner will assist Contractor in such matters when necessary.
2. Contractor shall give due and adequate notices to those in control of all properties which may be affected by his operations, and shall comply with all laws, ordinances, rules and regulations bearing on the conduct of the Work. If Contractor observes that the Contract Documents are at variance therewith, he shall give Engineer prompt written notice thereof, and any necessary changes will be adjusted as provided for in these General Conditions.
3. If Contractor performs any Work knowing it to be contrary to such laws, ordinances, rules and regulations, and without such notice to Engineer, he shall bear all costs arising therefrom; however, it shall not be his prime responsibility to make certain that the Contract Documents are in accordance with such laws, ordinances, rules and regulations.

GC-6 GENERAL RULES OF THE CONTRACT: continued

- C. Remedies Not Exclusive: The duties and obligations imposed by these Contract Documents and the rights and remedies available hereunder and in particular, but without limitation, the warranties, guarantees and similar obligations imposed upon Contractor, and the rights and remedies available to Owner and Engineer hereunder will be in addition to and not a limitation of any otherwise imposed or available by Law, by special guarantee or other provisions of the Contract Documents.
- D. Patents and Royalties: Contractor shall pay all license fees and royalties and assume all costs incident to the use in the performance of the Work of any invention, design, process, product or device which is the subject of patent rights or copyrights held by others. Contractor shall indemnify and hold harmless Owner and Engineer and anyone directly or indirectly employed by either of them from and against all claims, damages, losses and expenses (including attorneys' fees) arising out of any infringement of patent rights or copyrights incident to the use in the performance of the Work or resulting from the incorporation in the Work of any invention, design, process, product or device not specified in the Bid Documents and Contract Drawings, and shall defend all such claims in connection with any alleged infringement of such rights.

GC-7 CONTRACTOR'S RESPONSIBILITIES AND RIGHTS:

A. Supervision:

1. Contractor shall supervise and direct the Work efficiently and with his best skill and attention. He shall be solely responsible for the means, methods, techniques, sequences, and procedures of construction used but he shall not be solely responsible for the negligence of others in the design or selection of a specific means, method, technique, sequence or procedure of construction which is specifically called for by the Bid Documents or Contract Drawings.
2. Contractor shall keep on the Work at the Project site, during its progress, a competent superintendent and any necessary assistants against whom Owner or Engineer have no reasonable objection.
3. The superintendent shall not be relieved except with the consent of Owner unless he proves to be unsatisfactory to Contractor or ceases to be in his employ. When the superintendent is on vacation or otherwise absent, a substitute against whom Owner or Engineer have no reasonable objection shall be provided.
4. The superintendent shall represent Contractor in his absence and all communications to him will be as binding as if given to Contractor.
5. When manufacturer's field services in connection with the erection, installation, start-up or testing of equipment furnished under this Contract, or instruction of Owner's personnel thereon are specified, Contractor shall keep on the Work, during its progress or as specified, competent manufacturer's field representatives and any necessary assistants against whom Owner or Engineer have no reasonable objection.

B. Duty to Examine and Compare Contract Documents:

1. Before starting and throughout the progress of the Work, Contractor shall carefully reexamine and compare the Contract Documents and check

GC-7 CONTRACTOR'S RESPONSIBILITIES AND RIGHTS: continued

and verify all figures shown thereon and all field measurements. He shall at once report in writing to Engineer any conflict, error, or discrepancy which he may discover and obtain an interpretation from Engineer before proceeding with any Work affected thereby.

2. Any conflict, error, or discrepancy discovered by Contractor, or which he should have discovered through proper examinations and comparisons and which is not reported at least ten (10) days before the date scheduled for starting that portion of the Work affected thereby, will not be grounds for claims for extensions of the Contract Time.

C. Safety and Protection:

1. Contractor shall be solely responsible for initiating, maintaining and supervising all safety precautions and programs in connection with the Work. He shall take all necessary precautions for the safety of, and shall provide the necessary protection to prevent damage, injury or loss to,
 - a. All employees on the Work and other persons who may be affected thereby,
 - b. All the Work and all equipment and materials to be incorporated therein, whether in storage on or off the site, and
 - c. Other property at the site or adjacent thereto, including trees, shrubs, lawns, walks, pavements, roadways, structures, and utilities except as designated for removal, relocation or replacement as part of the Work.
2. He shall comply with the Department of Labor Safety and Health Regulations for Construction promulgated under Section 107 of the Contract Work Hours and Safety Standards Act (PL 91-54; 40 U.S.C. 333) and under the Williams-Steiger Occupational Safety and Health Act of 1970 (PL 91-596; 29 U.S.C. 655, 657); or with any Federal, State or municipal safety laws or building codes which supplement or extend said regulations.
3. He shall designate a responsible member of his organization on the site whose duty shall be the enforcement of safety and health regulations. The name of such individual shall be posted in a conspicuous place.
4. His duties and responsibilities for the safety and protection of the Work shall continue until such time as the entire Work is completed and Engineer has issued a notice that the Work is acceptable.

D. Emergencies:

1. In emergencies affecting the safety of persons or the Work or property at the site or adjacent thereto, Contractor, without special instruction or authorization from Owner or Engineer, is obligated to act at his discretion to prevent threatened damage, injury or loss. He shall give Engineer prompt written notice of any significant changes in the Work or deviations in the Contract Documents caused thereby. A Contract Modification may be issued covering the changes and deviations involved.

2. If Contractor believes that additional work done by him in an emergency which arose from causes beyond his control entitles him to an increase in the Contract Price or an extension of the Contract Time, he may make a claim therefor and request a Contract Modification as provided in these General Conditions.

E. Subcontractors, Suppliers and Manufacturers:

1. Contractor shall not deviate from any list of Subcontractors, suppliers or manufacturers submitted prior to the Notice of Award except with written approval of Owner.
2. Contractor shall not utilize any other Subcontractor, supplier, or manufacturer against whom Engineer or Owner may have a reasonable objection.
3. Contractor shall not be required to utilize any Subcontractor, supplier or manufacturer against whom he has a reasonable objection.
4. Contractor shall be as fully responsible to Owner for the acts and omissions of all of his Subcontractors, suppliers and manufacturers, and of persons either directly or indirectly employed by them, as he is for the acts and omissions of persons directly employed by him.
5. Acceptance of any Subcontractor, supplier or manufacturer by Owner or Engineer shall not constitute a waiver of any right of Owner or Engineer to reject defective Work or Work not in accordance with the Contract Documents.
6. Contractor shall bind specifically every Subcontractor, supplier and manufacturer to the applicable terms and conditions of the Contract Documents for the benefit of Owner.
7. Nothing contained in the Contract Documents shall create any contractual relation between any Subcontractor, supplier or manufacturer and Owner or Engineer or any obligation on the part of Owner or Engineer to pay or to see to the payment of any moneys due any Subcontractor, supplier or manufacturer, except as may otherwise be required by Law. Owner or Engineer may, if so requested and to the extent practicable, furnish to any Subcontractor, supplier or manufacturer evidence of amounts paid to Contractor on account of Work furnished or performed by said Subcontractor, supplier or manufacturer in accordance with Contractor's schedule of values.

F. Labor, Equipment, Materials and Workmanship:

1. Unless otherwise specified, all equipment and materials shall be new and of good quality. All workmanship shall be of good quality and free from defects.
2. All equipment and materials incorporated in the Work shall be designed to meet the applicable safety standards of Federal, State and Local laws and regulations.
3. Contractor shall, if required, furnish satisfactory evidence as to the source, kind and quality of equipment and materials.
4. Contractor shall furnish, or require his subcontractors to furnish, proper tools and equipment and the services of all mechanics, laborers, and other employees necessary in the construction and execution of the Work and the placing of all equipment in service.

GC-7 CONTRACTOR'S RESPONSIBILITIES AND RIGHTS: continued

5. All equipment and materials shall be applied, installed, connected, erected, used, cleaned and conditioned in accordance with the instructions of the applicable manufacturer, fabricator, or processor, except as otherwise provided in the Contract Documents.
6. Employees of Contractor and of his subcontractors shall be competent and willing to perform the work required of them. Any employee who is disorderly, intemperate or incompetent, or who neglects or refuses to perform his work shall be discharged and shall not be reemployed except with consent of Owner.

G. Substitute Equipment or Materials:

1. Throughout the Contract Documents certain types of equipment or kinds of materials are specified by manufacturers' names or trade names and catalog numbers. Products of manufacturers other than those specified may be accepted if it is proved to the satisfaction of Engineer that they are equal or better in quality and serviceability, that their use will not require revisions of related work, and that there will be an advantage to Owner.
2. Requests for such substitutions shall be made in writing to Engineer. Contractor shall certify that the proposed substitution will perform adequately the duties imposed by the general design, be similar and of equal substance to that specified, and be suited to the same use and capable of performing the same function as that specified. The request must be supported by sufficient data and samples, if required, to permit a fair evaluation of the proposed substitute with respect to quality, serviceability, warranty, and cost.

H. Submittals:

1. The Work includes the preparation and submission of all Compliance Submittals, schedules, certificates and other submittals specified or required for coordination of the Work with Owner's Project, to show that the Work will conform with the design concept and intent of the Bid Documents and Contract Drawings and that all provisions thereof will be met with respect to completion on time, payments, and protection of Owner's interests.
2. Contractor shall transmit all such submittals to Engineer for acceptance unless otherwise specified, and shall make all modifications requested.

I. Construction Records:

1. Contractor shall keep one (1) record copy of all Contract Documents at the site in good order and annotated to show all changes made during the construction progress.
2. These shall be available to Engineer for his inspection at all times and must be delivered to him for Owner upon substantial completion of the Work.
3. Receipt and acceptance of construction records will be a prerequisite for final payment on the Contract.

GC-7 CONTRACTOR'S RESPONSIBILITIES AND RIGHTS: continued

J. Contractor's Right to Stop Work or Terminate Contracts:

1. If the Work should be stopped under an order of any court or other public authority, or by Owner, for a period exceeding ninety (90) days, through no act or fault of Contractor or of anyone employed by him, Contractor may, upon ten (10) days' written notice to Owner and Engineer, stop the Work or terminate this Contract and recover payment from Owner for all Work executed and equipment and material delivered to the site.
2. Should Engineer fail without cause to issue any Engineer's Estimate within ten (10) working days after receipt of Contractor's formal application for payment, submitted and supported as specified, or if Owner should fail to pay to Contractor within thirty (30) days after receipt of any Engineer's Estimate, then Contractor may, upon ten (10) days' written notice to Owner and Engineer, stop the Work or terminate this Contract as set out in the preceding paragraph.

K. Indemnifications:

1. Contractor shall indemnify and hold harmless Owner and Engineer and their agents and employees from and against all claims, damages, losses and expenses including attorneys' fees arising out of or resulting from the performance of the Work provided that any such claim, damage, loss or expense:
 - a. Is attributable to bodily injury, sickness, disease or death, or to injury to or destruction of tangible property (other than the Work itself) including the loss of use resulting therefrom, and
 - b. Is caused in whole or in part by any negligent act or omission of Contractor, any Subcontractor, manufacturer or supplier, anyone directly or indirectly employed by any of them or anyone for whose acts any of them may be liable, regardless of whether or not it is caused in part by a party indemnified hereunder.
2. In any and all claims against Owner or Engineer or any of their agents or employees by any employee of Contractor, any Subcontractor, manufacturer or supplier, anyone directly or indirectly employed by any of them or anyone for whose acts any of them may be liable, this indemnification obligation is not limited in any way by any limitation on the amount or type of damages, compensation or benefits payable by or for Contractor or any Subcontractor, manufacturer or supplier under workmen's compensation acts, disability benefit acts or other employee benefit acts.
3. The obligations of Contractor shall not extend to the liability of Engineer, his agents or employees arising out of
 - a. The preparation or acceptance of maps, drawings, opinions, reports, surveys, Contract Modifications, designs or specifications, or
 - b. The giving of or the failure to give communications by Engineer, his agents or employees provided such giving or failure to give is the primary cause of injury or damage.

- L. Prompt Written Notice of Claim Required: Should Contractor claim extra compensation, injury or damage because of any error, omission, or act of Owner or Engineer or any of their agents or employees or any other

GC-7 CONTRACTOR'S RESPONSIBILITIES AND RIGHTS: continued

person for whose acts they may be legally liable, claim must be made in writing to Owner promptly after first observation of the error, omission or act giving rise to the claim. Thereafter, Contractor shall, at the times and in the form requested by Engineer, furnish Engineer with a detailed and current statement and accounting of the bases for the claim.

GC-8 OWNER'S RESPONSIBILITIES AND RIGHTS:

- A. Communications with Contractor: All communications of Owner with Contractor pertaining to performance of the Work will be issued through Engineer.
- B. Owner's Right To Correct or Complete the Work: If Contractor should neglect to prosecute the Work properly or fail to perform any provision of this Contract including cleaning up, Owner, after ten (10) days' written notice to Contractor, may, without prejudice to any other remedy he may have, make good such deficiencies and may deduct the cost thereof from the payment then or thereafter due Contractor.
- C. Owner's Right To Suspend Work:
1. Owner may, at any time and without cause, suspend the Work or any portion thereof for a period or successive periods of not more than ninety (90) days in the aggregate by notice in writing to Contractor and Engineer which will fix the date on which the Work shall be resumed. Contractor shall resume the Work on the date so fixed. Contractor shall be allowed an increase in the Contract Price or an extension of the Contract Time, or both, directly attributable to any suspension ordered by Owner without cause if he makes a claim therefor as provided in these General Conditions.
 2. Pending settlement of disputes on any point of controversy, Owner may suspend action on all or any part of the Work. Contractor is not entitled to any claim for loss or damage by reason of such delay nor to extension of the Contract Time, although such extensions of time may be recommended by Engineer if he deems it in the interest of the Work.
- D. Owner's Right to Terminate Contract:
1. Owner, upon the certificate of Engineer that sufficient cause exists to justify such action, may, without prejudice to any other right or remedy and, after giving Contractor and his surety ten (10) days' written notice, terminate the services of Contractor and take possession of the site and all equipment, materials, tools, and construction equipment thereon and finish the Work by whatever method he may deem expedient if Contractor becomes unacceptable for any of the following reasons:
 - a. If he is adjudged a bankrupt or insolvent.
 - b. If he makes a general assignment for the benefit of his creditors.
 - c. If he files a petition to take advantage of any debtor's act or reorganize under the bankruptcy or similar laws.
 - d. If a trustee or receiver is appointed for Contractor or for any of his property.

GC-8 OWNER'S RESPONSIBILITIES AND RIGHTS: continued

- e. If he persistently or repeatedly refuses or fails, except in cases for which extension of the Contract Time is provided, to supply proper supervision, acceptable equipment or materials, or enough properly skilled workmen, tools and construction equipment.
 - f. If he fails to make prompt payments to Subcontractors, suppliers or manufacturers for labor, equipment or material.
 - g. If he persistently disregards laws, ordinances or the authority of Engineer.
 - h. If he is guilty of a violation of any provision of the Contract Documents, and fails to remedy same within ten (10) days after written notice by Engineer.
2. In such case Contractor shall not be entitled to receive any further payment until the Work is finished.
 3. If the unpaid balance of the Contract Price exceeds the direct and indirect costs of finishing, or otherwise obtaining, the Work including compensation for additional engineering, managerial, and administrative services, such excess shall be paid to Contractor.
 4. If such costs exceed such unpaid balance, Contractor shall pay the difference to Owner.
 5. The costs incurred by Owner as herein provided, and the damage incurred through Contractor's default, will be verified by Engineer.

E. Use of Completed Work:

1. Owner has the right to take possession of or use of any completed or substantially completed portions of the Work at any time, but such taking possession or use will not be deemed an acceptance of any Work not completed in accordance with the Contract Documents.
2. Owner's use of any facilities so provided for in Division 1 of the Specifications will not be grounds for extension of the Contract Time or change in the Contract Price.
3. Owner's use of any facilities not specifically provided for in these Contract Documents will be in accordance with conditions agreed to prior to such use, and any extra costs or delay in completion incurred and properly claimed by Contractor will be equitably adjusted with a Contract Modification.
4. Facilities completed in accordance with the Contract Documents which are occupied or used by Owner prior to substantial completion of the entire Work will be defined in writing and accepted by Owner.
5. Guarantee periods on accepted Work, including mechanical and electrical equipment will commence upon the start of commercial use by Owner.
6. After all tests and instruction of Owner's personnel have been satisfactorily completed, Owner shall assume responsibility for and operation of all facilities occupied or used except for portions of the Work not yet completed by Contractor.

- F. Prompt Written Notice of Claim Required: Should Owner claim compensation, injury or damage because of any error, omission or act of Contractor, his Subcontractors, agents or employees or any other person for whose acts he may be legally liable, claim must be made in writing to Contractor promptly after the first observation of the error, omission or act giving rise to the claim.

GC-9 ENGINEER'S STATUS DURING PERFORMANCE OF THE WORK:

- A. Owner's Consultant: Engineer as the design professional will be Owner's consultant during the performance of the Work. The duties and responsibilities and the limitations of authority of Engineer as Owner's consultant during this period are set forth in these General Conditions and will not be extended without written consent of Owner and Engineer. In the event of extension of Engineer's duties and responsibilities, Contractor will be provided with written notice of such amendment.
- B. Role as Interpreter: Engineer will be the initial interpreter of the terms and conditions of the Contract Documents and the judge of the performance thereunder. In his capacity as interpreter and judge he will exercise his best efforts to insure faithful performance by both Owner and Contractor. He will not show partiality to either and shall not be liable for the result of any interpretation or decision rendered in good faith. All matters relating to the execution and progress of the Work, or the interpretation of or performance under the Contract Documents, shall be referred initially to Engineer for decision; which he will render promptly.
- C. Interpretations by Engineer: Engineer will issue with reasonable promptness such written interpretations of the Contract Documents (in the form of Drawings or otherwise) as he may determine necessary, which will be consistent with or reasonably inferable from the overall intent of the Contract Documents. If Contractor believes that a written interpretation amounts to a change in the Work, he shall so state in writing to Engineer.
- D. Visits to Site: Engineer will make periodic visits to the site to observe the progress and quality of the executed Work and to determine, in general, if the Work is proceeding in accordance with the Contract Documents. He will not be required to make exhaustive or continuous inspections to check the quality or quantity of the Work. He will keep Owner informed of the progress of the Work.
- E. Resident Project Representative:
1. Engineer will assign a full-time Resident Project Representative and assistants to assist Engineer in carrying out his responsibilities at the site. Resident Project Representative will serve as Engineer's liaison with Contractor at the site, working principally through Contractor's superintendent.
 2. Communications pertaining to Compliance Submittals, written interpretations, and Contract Modifications shall be directed to Engineer at his home office with copies to Resident Project Representative.
 3. Communications pertaining to day-to-day operations at the site shall be directed to Resident Project Representative.
 4. Resident Project Representative and his assistants will conduct observations of the Work in progress to assist Engineer in determining that the Work is proceeding in accordance with the Contract Documents.
 5. Resident Project Representative will not have authority to permit any deviation from the Contract Documents, except with concurrence of Engineer.

F. Authority to Disapprove or Reject Defective Work:

1. All equipment and materials used and all Work done will at all times be subject to the inspection, tests, and approval of Engineer or his authorized representatives.
2. Engineer has authority to disapprove or reject Work which is "defective" (which term is defined in these General Conditions, Article "Rules Governing Acceptance of the Work"). He also has authority to require special inspection or testing of the Work as provided in these General Conditions whether or not the Work is fabricated, installed or completed.
3. Resident Project Representative has authority, subject to final decision of Engineer, to disapprove or reject any defective workmanship, equipment or material.

G. Limitations on Engineer's Responsibilities:

1. Neither Engineer's authority to act under these General Conditions nor any decision made by him in good faith either to exercise or not exercise such authority will give rise to any duty or responsibility of Engineer to Contractor, any Subcontractor, supplier or manufacturer, any of their agents or employees, or any other person performing any of the Work.
2. Engineer is not responsible for the construction means, methods, techniques, sequences or procedures, or the safety precautions and programs incident thereto. Neither is he responsible for Contractor's failure to perform the Work in accordance with the Contract Documents.
3. Engineer is not responsible for the acts or omissions of Contractor or any Subcontractor, supplier or manufacturer, or any of his or their agents or employees, or any other persons performing any of the Work.
4. The presence or absence of Engineer or his representative will not act to relieve Contractor of any responsibility or of any guarantee of his performance. Neither will observation by Engineer or his representative in any way be understood to relieve Contractor of any responsibility for proper supervision of the Work at all times.
5. The review and acceptance of Contractor's Compliance Submittals by Engineer will be understood to be only for conformance with the design concept, for compliance with the intent of the Contract Documents, and to assist Contractor in interpreting the Contract Documents so as to preclude delivery of equipment or materials not acceptable for the Work. Engineer's acceptance of Compliance Submittals will not place upon him any responsibility for any deviations from the requirements of the Contract Documents unless Contractor has in writing called Engineer's attention to such deviation at the time of the submission and Engineer has given written concurrence on the specific deviation.

H. Engineer's Estimates:

1. The Engineer's Estimate in consequence of any Contractor's application for payment will constitute a representation by him to Owner, based on Engineer's observations of the Work in progress as an experienced and qualified design professional and on his review of the application for payment and accompanying data and schedules that the Work has progressed to the point indicated; that to the best of his knowledge, information and belief the quality of the Work is in accordance with the Contract Documents (subject to an evaluation of

GC-9 ENGINEER'S STATUS DURING PERFORMANCE OF THE WORK: continued

- the Work as a functioning project upon Substantial Completion, to the results of any subsequent tests called for in the Contract Documents and any qualifications stated in his Estimate); and that Contractor is entitled to payment of the amount shown in the Engineer's Estimate.
2. Engineer will not be deemed by his rendering of any Estimate to have represented that he made exhaustive or continuous inspections to check the quality or the quantity of the Work, or that he has reviewed the means, methods, techniques, sequences and procedures of construction or that he has made any examination to ascertain how or for what purpose Contractor has used the moneys paid or to be paid to him on account of the Contract Price or that title to any Work, equipment or materials has passed to Owner free and clear of any Liens.
 3. Engineer may refuse to render an Engineer's Estimate for the whole or any part of any payment if, in his opinion, it would be incorrect to make the above representations to Owner. He may also refuse to render any Engineer's Estimate or, because of subsequently discovered evidence or the results of subsequent inspections or tests, nullify any such previous Engineer's Estimate to such extent as may be necessary in his opinion to protect Owner from loss because of any reason set forth in General Conditions Article "Payments and Completion," paragraph "Payments Withheld."

GC-10 ADDITIONAL, OMITTED, OR CHANGED WORK:

A. Changes in the Work:

1. Owner, without invalidating the Agreement, may order additional Work or make changes by altering, adding to, or deducting from the Work, the Contract Price being adjusted accordingly. All such Work shall be executed under the conditions of the Contract Documents and be subject to the same inspection and tests as though initially included therein. Any claim for extension of the Contract Time caused thereby will be adjusted at the time of ordering such change.
2. Engineer may order minor changes in the Work to accommodate unforeseen circumstances and not inconsistent with the overall intent of the Contract Documents. If Contractor believes that any such change ordered by Engineer entitles him to a change in the Contract Price or Contract Time, he shall make a written statement of claims to Owner. The statement shall be delivered to Owner prior to beginning the portion of Work effected by Engineer's Order. Any change to the Contract Price or Contract Time arising from any such claim will be incorporated in a Contract Modification.
3. Except in an emergency endangering life or property, no extra Work or change involving time or cost not provided for in the Agreement shall be performed unless in pursuance to a Contract Modification which will state the location, character, amount, and method of compensation. No claim for an addition to the Contract Price or an extension to the Contract Time will be valid unless so ordered.

B. Changes to the Contract Price:

1. The Contract Price may be adjusted by only a Contract Modification. The Contract Price constitutes the total compensation payable to Contractor for performing the Work. All duties, responsibilities and obligations assigned to or undertaken by Contractor in accomplishing the Work shall be at his expense.
2. Renewal of labor contracts at higher wage rates will not be grounds for adjustment to the Contract Price.
3. Contractor shall not make any claim for an increase in the Contract Price by reason of cost increases or other labor troubles of any kind except as provided for in the bid and incorporated in the agreement.
4. Adjustments to the Contract Price for extra work or changes ordered by Owner will be determined by one or more of the following methods as agreed upon prior to starting the additional or changed work.
 - a. By a lump sum price.
 - b. By unit prices named in the Bid or as otherwise agreed.
 - c. By Contractor's cost plus a fixed fee.
 - d. By Contractor's cost plus a percentage.
5. The "Contractor's cost" is hereby defined for purposes of this Article to be the amounts required to pay Subcontractors plus the costs of his own Work as follows:
 - a. Labor Costs:
 - (1) The payroll cost for all workmen such as foremen, mechanics, craftsmen, and laborers.
 - (2) All incidental labor expenses incurred as a direct result of the performance of the Work, including payroll taxes, workmen's compensation, pension and retirement allowances, and social insurance, or other regular payroll charges on same.
 - b. Equipment and Material Costs:
 - (1) The cost of all equipment and materials required, delivered to the construction site, which are not furnished by Owner or others.
 - (2) Sales and use taxes applicable to such equipment and materials.
 - c. Supplemental Costs:
 - (1) Rental for all power-driven equipment at agreed-upon rates will be charged against additional or changed Work only for the actual time which the equipment is used specifically therefor.
 - (2) Transportation charges necessarily incurred in connection with such equipment which is not already on the site.
 - (3) Cost of power, fuel, lubricants and water required for such equipment (may be included in agreed-upon rate).
 - (4) Additional cost for surety bonds, liability and property damage, and other insurance required, where cost is necessarily increased by coverage of the additional or changed Work.
 - d. The above definitions and requirements apply equally to Work done by Subcontractors, suppliers and manufacturers under methods 4.c. or 4.d.
 - e. The percentage which shall be added to the several items of Contractor's cost under method 4.d. are as follows:
 - (1) Amounts paid to Subcontractors - Ten percent (10%).
 - (2) Labor Costs - Fifteen percent (15%).

GC-10 ADDITIONAL, OMITTED, OR CHANGED WORK: continued

- (3) Equipment and Material Costs - Ten percent (10%).
 - (4) Supplemental Costs - None.
 - f. Under method 4.c. or 4.d., compensation or adjustment to Subcontractors suppliers and manufacturers for Work done by them will be determined in accordance with any of the four methods set forth in Paragraph B.4. as agreed. (However, all such work done under method 4.b. shall be charged to Owner at unit prices not exceeding those set forth in the Bid.)
 - g. The above percentages include all other costs and full compensation for profit, overhead, superintendence, field office expense, and all other elements of cost not included in the "Contractor's cost" as herein defined.
 - h. Contractor shall keep and present in an acceptable form an accurate account with vouchers of the several items of cost, including those of Subcontractors, on changed or extra Work done under methods 4.b., 4.c. or 4.d.
 6. Changed work will be adjusted considering separately the parts of Work added and the parts omitted. Amount of adjustment for parts omitted will be estimated at the time the omission is authorized, and the agreed adjustment will be deducted from subsequent Engineer's Estimates.
 7. Statements for additional or changed work shall be rendered by Contractor not later than ten (10) days after completion of each assignment of additional or changed work provided for in a Contract Modification, and if found correct will be accepted by Engineer and submitted for payment with the next Engineer's Estimate.
 8. Owner reserves the right to obtain any or all extra Work from persons or firms other than Contractor.
 9. Contractor is not entitled to claim for damages for anticipated profits on any portion of the Work that may be omitted.
- C. Changes to the Contract Time:
1. The Contract Time may be adjusted by only a Contract Modification. Contractor, in undertaking to complete the Work within the Contract Time, has taken into consideration and made allowances for all of the ordinary delays and hindrances incident to such Work, whether growing out of delays in securing equipment or materials or workmen or otherwise.
 2. Adjustments to the Contract Time will be made for delays in completion of the Work from causes beyond Contractor's control, including the following:
 - a. Federal embargoes, priority orders, or other restrictions imposed by the United States Government.
 - b. Unusual delay in fabrication or shipment of equipment or materials required in the Work, whether ordered by Contractor or furnished by Owner or others under separate contract.
 - c. Abandonment of the Work by the men engaged thereon through no fault of Contractor.
 - d. Delays caused by court proceedings.
 - e. Contract Modifications.
 - f. Neglect, delay or default of any other contractor employed by Owner.
 - g. Weather conditions resulting in unusual construction delays.
 - h. Conflicts, errors or discrepancies in the Bid Documents or Contract Drawings reported to Engineer as provided in these General Conditions.

GC-10 ADDITIONAL, OMITTED, OR CHANGED WORK: continued

3. Contractor has no right to damages for any such causes of delay, but Owner shall award extensions of the Contract Time on account of such causes of delay, provided that adequate evidence is presented to enable Engineer to determine with exactness the extent and duration of delay for each item involved.
4. No extension to the Contract Time will be granted for delays involving only portions of the Work, or which do not directly affect the time required for completion of the entire Work.
5. Any claim for an extension to the Contract Time shall be delivered in writing to Owner and Engineer within ten (10) days of the occurrence of the event giving rise to the claim. All claims for adjustment to the Contract Time will be determined by Engineer if Owner and Contractor cannot otherwise agree. Any change to the Contract Time resulting from any such claim will be incorporated in a Contract Modification.

GC-11 RULES GOVERNING ACCEPTANCE OF THE WORK:

A. Warranty and Guarantee:

1. Contractor warrants and guarantees to Owner and Engineer that all equipment and materials will be new unless otherwise specified and that all Work will be of good quality and free from defects and in accordance with the Contract Documents and of the requirements of any inspections, tests or approvals provided for in the Contract Documents.
2. Contractor guarantees to remedy promptly, and without cost to Owner, any defective equipment, materials, or workmanship which appear within one (1) year after (the date of Substantial Completion or, if earlier,) the date Owner commences commercial use of the facilities and in accordance with any special guarantees provided for in the Contract Documents.
3. All equipment and materials furnished by Contractor for the Work shall carry a written guarantee from the manufacturer or supplier of such items when called for in the Specifications. Such guarantee shall cover and name all provisions set forth above and as may be called for in the Specifications. Written guarantees shall be submitted to Engineer with other Compliance Submittals. Engineer will transmit such guarantees to Owner for review by an attorney.
4. No provision in the Contract Documents nor any specified guarantee time limit shall be held to limit Contractor's liability for defects to less than the legal limit of liability in accordance with the Law.

B. Access to the Work: Engineer and his representatives and, Owner and his representatives and representatives of the Environmental Protection Agency and Missouri Clean Water Commission shall have access to the Work at all times during working hours. Contractor shall provide proper facilities for safe access and observation of the Work and also for any inspection or testing thereof by public authorities or others.

C. Tests and Inspections:

1. If the Contract Documents, laws, ordinances, rules, regulations or orders of any public authority having jurisdiction require any Work to specifically be inspected, tested, or approved by some public authority, Contractor shall give Engineer timely notice of readiness

GC-11 RULES GOVERNING ACCEPTANCE OF THE WORK: continued

therefor. Contractor shall assume all responsibility for such inspections and tests and shall furnish Engineer the required certificates of inspection, testing or approval.

2. Tests and inspections called for in these Contract Documents not otherwise prescribed by Law will be in accordance with standards set forth in the Specifications.
3. No inspection, test or approval will be construed to relieve Contractor from his obligations to perform the Work in accordance with the Contract Documents.

D. Defective Work:

1. The term "defective" is used in these documents to describe Work that is unsatisfactory, faulty, not in conformance with the requirements of the Contract Documents, or not meeting the requirements of any inspection, test, approval or acceptance required by Law or the Contract Documents.
2. Any defective Work may be disapproved or rejected by Engineer at any time before final acceptance even though it may have been overlooked and included in a previous Engineer's Estimate.
3. Contractor shall furnish samples of questionable equipment or materials from completed Work for testing purposes when required by Engineer. All costs in connection with the testing of equipment and materials proven to be defective shall be paid by Contractor through a deductive Contract Modification. If such tests prove the equipment or materials to be acceptable, their cost will be paid by Owner.
4. Prompt notice will be given by Engineer to Contractor of all defects as they become evident.

E. Uncovering Work:

1. If any Work is covered without concurrence of Engineer it must, if requested by Engineer, be uncovered for his observation. Such Work will be at Contractor's expense unless Contractor has given Engineer timely notice and Engineer has not acted within a reasonable time.
2. If Engineer considers it necessary or advisable that Work covered with his concurrence be reexposed for his observation or for inspection or testing by others, Contractor shall, at Engineer's request, uncover, expose or otherwise make available for observation, inspection or testing, that portion of the Work in question. If Engineer finds that such Work is defective, Contractor shall bear all the expenses of such uncovering, exposure, observation, inspection and testing and of satisfactory reconstruction including compensation for additional professional services, and an appropriate deductive Contract Modification will be issued. If, however, such Work is found to be acceptable, Contractor will be allowed an increase in the Contract Price or an extension of the Contract Time, or both, directly attributable to such uncovering, exposure, observation, inspection, testing and reconstruction if he makes a claim therefor as provided in these General Conditions.

- F. Stopping Defective Work in Progress: If the Work is defective, or Contractor fails to supply sufficient skilled workmen or suitable equipment or materials, Owner or Engineer may order Contractor to stop the Work or any portion thereof until the cause for such order has been eliminated;

GC-11 RULES GOVERNING ACCEPTANCE OF THE WORK: continued

however, this right of Owner or Engineer to stop the Work will not give rise to any duty on the part of Owner or Engineer to exercise this right for the benefit of Contractor or any other party.

G. Removal and Replacement of Rejected Defective Work:

1. All rejected defective Work, whether or not fabricated, installed or completed, shall be removed from the site and replaced with acceptable Work.
2. If Contractor does not remove and replace such rejected Work within a reasonable time, all as specified in a written notice from Engineer, Owner may, as provided in these General Conditions:
 - a. Withhold payment, or
 - b. Stop the Work, or
 - c. Remove and replace the rejected Work. All direct and indirect costs of such removal and replacement, including compensation for additional professional services, shall be paid by Contractor. Contractor shall also bear the expenses of making good all work of others destroyed or damaged by the removal and replacement of his defective Work. Rejected equipment and materials removed from the Work by Owner shall be removed from the site by Contractor if so directed by Owner or Engineer within ten (10) days of written notice of availability. Equipment and materials not removed within such time may be sold by Owner and the net proceeds therefrom deducted from the expense of removal and replacement chargeable to Contractor. An appropriate deductive Contract Modification will be issued to cover all costs incurred by Owner in connection with the removal and replacement of defective Work.

H. Correction or Repair of Defective Work:

1. If required by Engineer, Contractor shall promptly correct or repair any defective Work, whether or not fabricated, installed or completed.
2. If Contractor does not correct or repair such defective Work within a reasonable time, all as specified in a written notice from Engineer, it may be rejected as specified in the preceding paragraph or Owner may have the deficiency corrected by others. All direct and indirect costs of such correction or repair, including compensation for additional professional services, shall be paid by Contractor. Contractor shall also bear the expenses of making good all work of others destroyed or damaged by correction or repair of his defective Work. An appropriate deductive Contract Modification will be issued to cover all costs incurred by Owner in connection with the correction or repair of defective Work.

- I. Acceptance of Defective Work: If instead of requiring correction, repair, or removal and replacement of defective work, Owner (and, prior to approval of final payment, also Engineer) deems it expedient to accept it, he may do so. In such case if acceptance occurs prior to approval of final payment, a Contract Modification will be issued incorporating the necessary revisions in the Contract Documents, including an appropriate reduction in the Contract Price; or, if the acceptance occurs after approval of final payment, an appropriate amount shall be paid by Contractor to Owner.

GC-11 RULES GOVERNING ACCEPTANCE OF THE WORK: continued

J. Correction of Defective Work During the Guarantee Period:

1. If, during the guarantee period, any Work is found to be defective, Contractor shall promptly, without cost to Owner and in accordance with Owner's or Engineer's written instructions, either correct such defective Work or, if it has been rejected by Owner or Engineer, remove it from the site and replace it with acceptable Work.
2. If Contractor does not promptly comply with the terms of such instructions, Owner may have the defective Work corrected or the rejected Work removed and replaced and all direct and indirect costs of such correction or removal and replacement, including compensation for additional professional services, shall be paid by Contractor.
3. Contractor shall also bear the expenses of making good all other work destroyed or damaged by the correction or removal and replacement of the defective Work.
4. Owner or Engineer shall give notice of observed defects with reasonable promptness.
5. Under emergency conditions Owner may remedy defective Work without waiting for action by Contractor. Owner or Engineer will notify Contractor immediately of the circumstances and actions taken and Contractor shall pay all reasonable substantiated costs of such actions.

GC-12 PAYMENTS AND COMPLETION:

A. Schedule of Values: Concurrently with submission of the first detailed progress schedule, Contractor shall submit a detailed schedule of values of the Work, including quantities and unit prices, aggregating to the Contract Price. The schedule shall be in a form similar to the subdivisions of the Specifications. The schedule shall subdivide the Work into component parts in sufficient detail to serve as a basis for computing partial payments during construction. The value of equipment and materials delivered to the site may be listed separately from the cost of their installation. If such values are not separately listed, no payment will be made for equipment or materials until they are installed. Bond, insurance, and mobilization expenses may be listed separately. The schedule of values shall be revised, if required, and must be acceptable to Engineer prior to processing the first partial payment. All pay items must be supported with acceptable documentation.

B. Partial Payments:

1. On or about the first day of each month Contractor shall submit to Engineer an itemized application for partial payment, supported with such evidence of Contractor's right to payment as Engineer may prescribe.
2. Each application for a partial payment shall be accompanied with Contractor's updated progress and procurement schedules.
3. If payments are to be made on account of equipment or materials not incorporated in the Work but delivered and suitably stored at the site or at some other location agreed upon in writing, such payments shall be conditioned upon submission by Contractor of bills of sale

GC-12 PAYMENTS AND COMPLETION: continued

- or such other procedure as will establish Owner's title to such equipment or materials or otherwise adequately protect Owner's interest including applicable insurance. Each subsequent application for payment shall include an affidavit of Contractor stating that all previous partial payments received on account of the Work have been applied to discharge in full all of Contractor's obligations reflected in prior applications for payment.
4. Upon receipt of each Contractor's application for a partial payment, Engineer will within ten (10) days make an Engineer's Estimate equal to the value of all Work accomplished prior to the date of the Contractor's application, and the value of unused equipment and materials delivered and stored on the site, and equipment and materials, if any, stored acceptably off the site, based upon the Contractor's application and schedule of values. Each Engineer's Estimate shall be signed by Contractor or be accompanied by his application for payment to indicate Contractor's concurrence with the amount due. When Engineer's Estimate has been delivered to Owner by Engineer, Owner shall pay Contractor the amount due within thirty (30) days after receipt thereof.
 5. Partial payments will be in the amount of ninety percent (90%) of the amount of the Engineer's Estimate less the sum of all previous payments. When the amount retained by Owner becomes equal to five percent (5%) of the Contract Price, the remaining partial payments will be made in full provided Contractor's performance is satisfactory in the opinions of Engineer and Owner.
 6. Adjustments may be made in any Engineer's Estimate for variations in quantities of certain items at the unit prices named in the Bid. All other variations must be made as provided under Article "Additional, Omitted, or Changed Work."
 7. Partial payments will not be construed as an acceptance of any part of the Work.
- C. Contractor's Warranty of Title: Contractor warrants and guarantees that title to all Work, equipment and materials covered by an application for payment, whether incorporated in the Work or not, will pass to Owner at the time of payment, free and clear of all liens, claims, security interests and encumbrances (referred to in these General Conditions as "Liens").
- D. Payments Withheld:
1. Owner may, when so advised by Engineer, withhold or, on account of subsequently discovered evidence, nullify the whole or a part of any Contractor's application for payment or Engineer's Estimate to such extent as may be necessary to protect himself from loss on account of the following:
 - a. Defective workmanship, equipment or material not remedied or replaced by Contractor.
 - b. Reduction in the Contract Price because of pending modifications.
 - c. Claims filed, or reasonable evidence indicating probable filing of claims.
 - d. Failure of Contractor to make payments properly to Subcontractors, suppliers and manufacturers or for equipment, material or labor.
 - e. Damage to another contractor.

GC-12 PAYMENTS AND COMPLETION: continued

- f. Any other violation of or failure to comply with the provisions of the Contract Documents, including failure to clean up or submit acceptable Compliance Submittals.
2. When all grounds for withholding payment are removed payment will be made in the amounts withheld because of them.

E. Substantial Completion:

1. When he considers the Work or any part thereof ready for full occupancy or utilization by Owner, Contractor shall declare in writing to Owner and Engineer that the Work or part is substantially complete and request that Engineer issue a Certificate of Substantial Completion therefor.
2. Within a reasonable time thereafter, Owner, Contractor and Engineer will make an inspection of the Work or part to determine the status of completion. If Engineer does not consider the Work or part substantially complete, he will notify Contractor in writing giving his reasons therefor. If Engineer considers the Work or part substantially complete, he will prepare and deliver to Owner a tentative Certificate of Substantial Completion which will fix the Substantial Completion Date and the responsibilities between Owner and Contractor for operation, heat, utilities and maintenance. There will be attached to the Certificate a tentative list of items to be completed or corrected before final payment, and the Certificate will fix the time within which such items shall be completed or corrected.
3. Owner shall have ten (10) days after receipt of the tentative Certificate during which he may make written objection to Engineer as to any provisions of the Certificate or attached list.
 - a. If after considering such objections Engineer concludes that the Work is not substantially complete, he will notify Contractor in writing, stating his reasons therefor.
 - b. If after ten (10) days and after consideration of Owner's objection Engineer considers the Work or part substantially complete, he will execute and deliver to Owner and Contractor a definitive Certificate of Substantial Completion, with a revised list of items to be completed or corrected, reflecting such changes from the tentative certificate as he believes justified after consideration of any objections from Owner.
4. Owner shall have the right to exclude Contractor from substantially completed Work after the Substantial Completion Date, but Owner will allow Contractor reasonable access to complete or correct items on the definitive list.
5. If after Substantial Completion of the entire Work final completion thereof is materially delayed through no fault of Contractor and Engineer so confirms, Owner shall, without terminating the Agreement, make payment of the balance due for the Work substantially completed and accepted. Such payment will be made in accordance with the terms and conditions set forth under "Final Inspection and Acceptance" and "Final Payment" except that it will not constitute a waiver of claims. The Contractor's application for payment shall, in addition to all other required documents, include the written consent of his surety to such payment and an estimate of the value of the Work not fully completed or corrected.

GC-12 PAYMENTS AND COMPLETION: continued

Payment for Substantial Completion will be made in the amount that would otherwise be due under "Final Payment" reduced by the amount approved by Engineer as the value of the Work not fully completed or corrected.

F. Final Inspection and Acceptance:

1. Upon written notice from Contractor that he considers all Work complete, Engineer will make a final inspection with Owner and Contractor and will notify Contractor in writing of any particulars in which this inspection reveals that the Work is incomplete or defective. Contractor shall promptly make all completions and corrections as are necessary to remedy such deficiencies.
2. After Contractor has remedied all deficiencies to the satisfaction of Engineer and delivered all construction records, maintenance and operating instructions, schedules, guarantees, Bonds, certificates of inspection and other documents -- all as required by the Contract Documents -- Owner and Contractor will be promptly notified in writing that the Work is acceptable subject to the provisions set forth under "Waiver of Claims."

G. Final Payment:

1. When Contractor is notified the Work is acceptable he shall make application for final payment following the procedure for partial payments.
2. The application for final payment shall be accompanied by such supporting data as Engineer may require, together with complete and legally effective releases or waivers satisfactory to Owner of all Liens arising out of the Contract Documents and the labor and services performed and the equipment and material furnished thereunder. In lieu thereof and as acceptable to Owner, Contractor may furnish receipts or releases in full with an affidavit of Contractor that the releases and receipts include all labor, services, equipment and material for which a Lien could be filed, and that all payrolls, equipment and material bills, and other indebtedness connected with the Work for which Owner or his property might in any way be responsible have been paid or otherwise satisfied; and Consent of the surety to final payment. If any Sub-contractor, manufacturer or supplier fails to furnish a release or receipt in full, Contractor may furnish a Bond satisfactory to Owner to indemnify him against any Lien.
3. If on the basis of his observation and review of the Work during the performance thereof, his final inspection and his review of the application for final payment -- all as required by the Contract Documents -- Engineer is satisfied that the Work has been completed and Contractor has fulfilled all of his obligations under the Contract Documents, he will within ten (10) days after receipt of the application for final payment prepare a Final Estimate indicating his concurrence with final payment and present it to Owner and Contractor. When Engineer's Final Estimate has been delivered to Owner by Engineer, Owner shall pay Contractor the amount due within thirty (30) days after receipt thereof.
4. The Final Estimate will include all sums remaining to be paid.

- H. Waiver of Claims: The making and acceptance of final payment shall constitute:
1. A waiver of all claims by Owner against Contractor other than those arising from unsettled Liens, from defective Work appearing after final inspection, or from failure to comply with the requirements of the Contract Documents or the terms of any special guarantees specified therein, and
 2. A waiver of all claims by Contractor against Owner other than those previously made in writing and still unsettled.
- I. Contractor's Continuing Obligation: Contractor's obligation to perform and complete the Work in accordance with the Contract Documents shall be absolute. Neither preparation of any partial or final Estimate by Engineer, nor the issuance of a Certificate of Substantial Completion, nor any payment by Owner to Contractor under the Contract Documents, nor any utilization of the Work or any part thereof by Owner, nor any act of acceptance by Owner nor any failure to do so, nor any failure to give prompt notice, nor any correction of defective Work by Owner will constitute an acceptance of Work not in accordance with the Contract Documents.

* * * * *

LABOR-RELATED REGULATIONS

L-RR-1 EQUAL EMPLOYMENT OPPORTUNITY:

The Contractor agrees to comply, and cause each subcontractor, if any, to comply with all Federal and state laws, regulations, and directives pertaining to equal opportunity employment in connection with this contract, including but not limited to employment, procurement of materials, and lease of equipment therefore.

L-RR-2 WAGE RATE STIPULATIONS:

- A. The BID, CONTRACT, and BONDS, shall be based upon the required payment by the Contractor and his subcontractors of not less than the prevailing hourly rate of wages, including the prevailing rate for legal holidays and overtime work, for each craft or type of workman required to execute the contract, as determined now or hereafter by the Missouri Department of Labor and Industrial Relations, Division of Labor Standards.
- B. The Contractor and each subcontractor shall comply with all requirements of the prevailing wage law of the State of Missouri, Sections 290.210 through 290.340 RsMo 1959, as amended 1969 and the wage provisions of the Labor Standards, Contract Provisions.
- C. The Contractor and each subcontractor shall keep an accurate record showing the names and occupations of all workmen employed, together with actual wages paid to each workman. At all reasonable hours, such records shall be open to inspection by representatives of the Division of Labor Standards of Missouri, the Owner, and the Engineer.
- D. The Contractor shall forfeit, as a penalty to the Owner, ten dollars (\$10) for each workman employed, for each calendar day or portion thereof, such workman is paid less than the said stipulated rates for any work done under this contract, by him or any subcontractor under him.
- E. During the life of this contract, the prevailing hourly rate of wages is subject to change by the Department of Labor and Industrial Relations or by court decision, as provided by law. Any such change shall not be the basis for any claim by the Contractor against the Owner, nor will deductions be made by the Owner against any sums due the Contractor by reason of any such change.

L-RR-3 WAGE RATE DETERMINATIONS:

The Division of Labor Standards wage rate determinations are published hereafter.

DIVISION 1 - GENERAL REQUIREMENTS

1-1 SUMMARY OF WORK:

- A. Description of Project: This is the first unit of a new plant. This unit will consist of a 235,000 kW turbine generator and a coal-fired steam generator. The unit will operate as a base load unit. Provisions are incorporated into the design for a future addition.
- B. Work Under This Contract:
1. This Contract includes, but is not limited to, the following items which are listed to facilitate understanding of the scope of the work:
 - a. Construction operation and maintenance of construction runoff retention system.
 - b. Construction of on-site roads, drives, laydown and parking areas.
 - c. Construction of cooling tower basin.
 - d. Construction of embankment for railroad loop and Missouri-Pacific Railroad access spur.
 - e. Construction of fly ash pond.
 - f. Construction of bottom ash scrubber sludge pond and discharge structures.
 - g. Construction and lining of coal yard and limestone yard.
 - h. Construction of process waste and settling ponds.
 - i. Construction of new concrete pedestrian bridge at the substation.
 - j. Construction of the bottom ash pond storm sewer culvert.
 - k. Excavation of clay liner on site.
 - l. Construction of fences and security guard house with electronic gates.
- C. Other Contracts: Other contracts related to this contract will include all general construction, mechanical and electrical work. All contracts have a completion schedule. Each item of equipment, phase of construction work, and contract must be completed and operational by the scheduled date to permit placing Unit No. 1 in commercial operation by June 1, 1981. The Contractor shall cooperate and make space available for other Contractors working on the project simultaneously, which include but not limited to the following contracts:
1. Contract 2 - Steam Generator.
 2. Contract 10 - Cooling Tower.
 3. Contract 11 - Coal Handling.
 4. Contract 32 - Site Preparation I.
 5. Contract 34 - Railroad.
 6. Contract 35 - Piling.
 7. Contract 36 - Foundation and Substructures.
 8. Contract 39 - Steel Structures.
 9. Contract 40 - Power Plant Structures.
 10. Contract 42 - Yard Structures.
 11. Contract 43 - Power Piping.
 12. Contract 44 - Equipment Erection.
 13. Contract 46 - Substation Construction.
 14. Contract 50 - Process Waste Treatment Plant.
 15. Contract 57 - Transmission Tower Erection.

1-1 SUMMARY OF WORK: continued

- D. Continuous Service of Existing Facilities: An existing power station, substation and transmission lines are in continuous operation. The Contractor will confine his work to the new site and will under no circumstances interfere with existing facilities.

1-2 ADMINISTRATIVE MATTERS:

- A. Initial Coordination Submittals: Within ten (10) days after the Notice to Proceed, Contractor shall submit to Engineer for review and acceptance:
1. A preliminary Work progress schedule.
 2. A tentative procurement schedule.
 3. A tentative schedule of values for partial pay purposes.
 4. A tentative schedule of Compliance Submittals, and
 5. Certification of insurance or copies of policies, all as described in the Contract Documents.
- B. Initial Coordination Conference: Within twenty (20) days after the Notice to Proceed, a conference will be held to review initial coordination submittals, establish procedures for handling Compliance Submittals, review procedures for payment of Contractor, and establish a working understanding between the parties as to their relationships during conduct of the Work. The conference shall be attended by:
1. Contractor and his Superintendent.
 2. Representatives of principal Subcontractors, suppliers and manufacturers.
 3. Engineer and his Resident Project Representative.
- C. Work Progress Schedule:
1. Contractor shall submit to Engineer for acceptance a detailed Work progress schedule within thirty (30) days after the Notice to Proceed.
 2. The schedule shall show the Work in a graphic format suitable for displaying scheduled and actual progress and shall be submitted on a reproducible media.
 3. The schedule shall show the Work broken down into major phases and key items. The dates Work is expected to begin and be completed shall be shown for each item listed.
 4. Engineer will review and comment on schedule and, upon agreement with Contractor on any necessary changes, Engineer will furnish Contractor prints of the accepted schedule. Contractor shall not change the accepted Work progress schedule without prior concurrence of Engineer.
 5. Contractor shall submit to Engineer for acceptance an updated schedule at least once each month which shall show actual progress and any proposed changes in the schedule of remaining Work.
- D. Work Progress Reports:
1. Contractor shall submit monthly a report on actual Work progress. Weekly reports may be required should the Work fall behind the accepted schedule.
 2. Work progress reports shall consist of marked copies of prints made from the accepted graphic Work progress schedule and a narrative report which shall include but not be limited to the following:
 - a. A description of current and anticipated delaying factors, if any.
 - b. Impact of any possible delaying factors.
 - c. Proposed corrective actions.
 3. A Work progress report shall accompany each application for partial payment. Work reported complete but not readily apparent to Engineer must be substantiated with supporting data.

1-2 ADMINISTRATIVE MATTERS: continued

4. Should operations fall behind the accepted schedule to an extent that Substantial Completion of the Work within the Contract Time appears doubtful, Contractor shall at no change in the Contract Price:
 - a. Add to his plant, equipment, and construction forces.
 - b. Or increase the working hours per week.
 - c. Or both a and b.

E. Coordination Conferences:

1. A coordination conference shall be held at least once each week and at other times requested by Engineer. Contractor, Engineer and all Subcontractors active on the site shall be represented at each conference. Contractor may at his discretion request attendance by representatives of his suppliers, manufacturers and other Subcontractors.
2. Contractor and each Subcontractor shall be prepared to discuss the current Work progress report and any anticipated future changes to the schedule. Each Subcontractor shall comment on the schedules of Contractor and other Subcontractors and advise if their current progress or future anticipated schedules are compatible with his work.
3. If one Subcontractor's work is delaying another's work, Contractor shall direct such changes as are necessary for those involved to mutually agree on schedule changes in the best interest of Work progress.
4. When Contractor's Work affects, or is affected by, the work of other prime contractors, Engineer may hold coordination conferences to be attended by those involved. Contractor shall participate in such conferences accompanied by his Subcontractors as requested by Engineer.

F. Procurement Schedule:

1. Contractor shall prepare and submit with the Work progress schedule a procurement schedule for equipment and materials to be furnished by him or his Subcontractors, manufacturers, and suppliers, and which are not known to be regularly stocked by local suppliers or readily available upon short notice.
2. Engineer will review and comment on the procurement schedule and, upon agreement with Contractor concerning any necessary changes, the schedule will be accepted.
3. Procurement schedule shall coincide with the Work progress schedule and shall indicate the date each item will be needed at the site to avoid delay in construction, the time required for delivery after order is placed, the latest date for placement of order, and whether or not Compliance Submittals are required.
4. The accepted procurement schedule shall be updated at least once each month and submitted with the Work progress report to show the status of orders placed, Compliance Submittals, and delivery. Copies or listings of material orders or subcontracts issued with their issue dates shall be included.
5. Contractor shall furnish to Engineer, if so requested, copies of any purchase order placed by him or his subcontractors.
6. Procurement schedule shall include all equipment and materials needed to complete the job.

1-2 ADMINISTRATIVE MATTERS: continued

G. Compliance Submittals:

1. Contractor shall prepare for Engineer's concurrence a schedule for submission of all Compliance Submittals specified or necessary for Engineer's approval of the use of equipment and materials proposed for incorporation in the Work or needed for proper installation, operation or maintenance. The schedule shall accompany the procurement schedule and Work progress schedule submitted to Engineer. Submission of all Compliance Submittals shall be scheduled to permit review, fabrication and delivery in time to cause no delay in the Work of Contractor or his Subcontractors or any other contractors as described herein.
 - a. Contractor in establishing his schedule for Compliance Submittals shall allow twenty (20) business days in Engineer's office for reviewing original submittals and fifteen (15) business days in Engineer's office for reviewing resubmittals.
 - b. The schedule shall indicate the anticipated dates of original submission for each item and Engineer's acceptance thereof, and shall be based upon at least one (1) resubmission of each item.
 - c. All Compliance Submittals of equipment and materials furnished by Subcontractors, manufacturers and suppliers shall be submitted to Engineer by Contractor.
 - d. All Compliance Submittals required prior to fabrication or manufacture shall be scheduled for submission within ninety (90) days of the Notice to Proceed. Compliance Submittals pertaining to storage, installation and operation at the site shall be scheduled for Engineer's acceptance prior to delivery of the equipment or materials.
 - e. Compliance Submittals shall be resubmitted the number of times required for Engineer's "Submittal Accepted." However, any need for resubmittals in excess of the number set forth in the accepted schedule, or any other delay in obtaining acceptance of submittals, will not be grounds for extension of the Contract Time provided Engineer completes his reviews within the times stated above.
2. After checking and verifying all field measurements, Contractor shall transmit all Compliance Submittals to Engineer for acceptance. Contractor shall:
 - a. Identify each submittal by Contract title, number and the Specification division and article number marked thereon or in the letter of transmittal.
 - b. Check and stamp submittals of Subcontractors, suppliers and manufacturers with his approval prior to transmitting them to Engineer. Contractor's stamp of approval shall constitute a representation to Owner and Engineer that Contractor has either determined and verified all quantities, dimensions, field construction criteria, materials, catalog numbers and similar data or he assumes full responsibility for doing so, and that he has coordinated each Compliance Submittal with the requirements of the Work and the Contract Documents.
 - c. At the time of each submission, call to the attention of Engineer in the letter of transmittal any deviations from the requirements of the Contract Documents.

1-2 ADMINISTRATIVE MATTERS: continued

3. Compliance Submittals shall include the following:
 - a. Manufacturer's specifications.
 - b. Fabrication and erection drawings.
 - c. General outline drawings of equipment showing overall dimensions, location of major components, weights, and locations of required building openings and floor plates.
 - d. Detailed equipment installation drawings showing foundation details, anchor bolt sizes and locations, base plate sizes, location of Owner's connections; and all clearances required for erection, operation, and disassembly for maintenance.
 - e. Schematic diagrams for electrical items showing external connections, terminal block numbers, internal wiring diagrams and one-line diagrams.
 - f. Bills of materials and spare parts lists.
 - g. Instruction books.
 - h. Samples, color charts and similar items.
 - i. All drawings, catalogs or parts thereof, manufacturer's specifications and data, samples, instructions, written guarantees and other information specified or necessary:
 - (1) For Engineer to determine that the equipment and materials conform with the design concept and comply with the intent of the Contract Documents.
 - (2) For the proper erection, installation, operation and maintenance of the equipment and materials which Engineer will review for general content but not for substance.
 - (3) For Engineer to determine what supports, anchorages, structural details, connections and services are required for the equipment and materials, and the effects on contiguous or related structures, equipment and materials.

Data submitted shall be complete with respect to dimensions, design criteria, materials of construction and the like to enable Engineer to review the information effectively. Where standard drawings are furnished which cover a number of variations of the general class of equipment, each such drawing shall be individually annotated to describe exactly which parts of the drawing apply to the equipment being furnished. Such annotation shall also include proper identification of the submittal permanently attached to the drawing. Reproduction or copies of Contract Drawings or portions thereof will not be accepted as complete fabrication or erection drawings, but will be acceptable when used by Contractor as a drawing upon which to indicate information on erection or to identify detail drawings.
4. Equipment instruction books shall be prepared by the manufacturer with loose-leaf pages mounted in durable covers and shall include, but not limited to the following:
 - a. Index and tabs.
 - b. Instructions for installation, startup, operation, inspection, maintenance, parts lists and recommended spare parts, and data sheets showing model numbers.
 - c. Applicable drawings.
 - d. Address of nearest manufacturer-authorized service facility.
 - e. All additional data specified.

1-2 ADMINISTRATIVE MATTERS: continued

5. Engineer will review and return Compliance Submittals to Contractor with appropriate notations. Written guarantees and similar submittals received by Engineer will be reviewed by an attorney for acceptance and returned by Engineer. Instruction books and similar submittals will be reviewed by Engineer for general content but not for substance. The approval for use of a separate item as such will not indicate approval for use of the assembly in which the item functions. Contractor shall make all modifications noted or indicated by Engineer and shall return revised prints, copies or samples until accepted. Contractor shall direct specific attention in writing, or on revised submittals, to changes other than the modifications called for by Engineer on previous submittals. After submittals have been accepted, Contractor shall submit copies thereof for final distribution. Prints of accepted drawings transmitted for final distribution will not be further reviewed and are not to be revised. If errors are discovered during manufacture or fabrication, the submittal shall be corrected and resubmitted for review.
 6. Following completion of the Work and prior to final payment, Contractor shall furnish those drawings necessary to indicate "as constructed" conditions, including field modifications, in the number of copies specified and furnish additional copies for insertion in equipment instruction books as required. All such copies shall be clearly marked "AS CONSTRUCTED."
 7. No Work requiring a Compliance Submittal shall be commenced or shipped until the submittal has been stamped "Submittal Accepted" or "Submittal Acceptable as Noted" by Engineer. A copy or sample of each Compliance Submittal shall be kept in good order by Contractor at the site.
 8. Engineer's acceptance of Compliance Submittals will not relieve Contractor from his responsibility for any deviations from the requirements of the Contract Documents unless Contractor has in writing called Engineer's attention to such deviation at the time of submission and Engineer has given written approval to the specific deviation, nor shall any acceptance by Engineer relieve Contractor from responsibility for errors or omissions in Compliance Submittals.
- H. Transmittal and Review of Compliance Submittals:
1. Except as otherwise specified, all manufacturer's or fabricator's drawings and specifications shall be transmitted as follows:
 - a. Initial submittal - reproducible sepia and two (2) copies to Engineer, sepia returned to Contractor.
 - b. Resubmittals - 1 reproducible and two (2) copies to Engineer, reproducible sepia returned to Contractor.
 - c. Submittal for final distribution - ten (10) copies to Engineer, plus the number of copies required by Contractor.
 - d. As-constructed prints - four (4) copies and one (1) reproducible sepia to Engineer.
 2. Submittals of material samples, color charts and similar items shall be as follows:
 - a. Initial submittal - three (3) to Engineer.
 - b. Resubmittal - three (3) to Engineer.Upon approval, one (1) sample will be returned to Contractor.

1-2 ADMINISTRATIVE MATTERS: continued

3. Submittals of catalog cuts shall be as follows:
 - a. Initial submittal - three (3) copies to Engineer, one (1) copy returned to Contractor.
 - b. Resubmittals - three (3) copies to Engineer, one (1) copy returned to Contractor.
 - c. Submittal for final distribution - ten (10) copies to Engineer plus the number of copies required by Contractor.
4. Submittals of equipment instruction books shall be as follows:
 - a. Eight (8) copies direct to Owner.
 - b. Five (5) copies direct to Engineer.
 - c. Two (2) copies direct to Engineer's field office.
 - d. Submit fifteen (15) copies of "as constructed" drawings for books if required.
5. Written guarantees shall be submitted in six (6) copies, 2 copies returned to Contractor. Same number for resubmittals.
6. Compliance Submittals for reference only will be submitted in eleven (11) copies, unless Contractor desires stamped copy.
7. Copies of the equipment contractor's erection drawings and other Compliance Submittals required for the installation of equipment furnished by others under separate contract for installation under this Contract will be transmitted to Contractor by Engineer in the final distribution of such submittals.
8. Engineer's review action stamp, appropriately completed, will appear on all Compliance Submittals of Contractor when returned by Engineer.

THIS COMPLIANCE SUBMITTAL REVIEWED BY PHELPS, HOGLAND & PHILLIPS ENGRG. CO. AND BURNS & McDONNELL ENGRG. CO. OWNER SIKESTON, MO. PROJECT NO. 76-076-1 CONTRACT NO. CONTRACT TITLE DATE RECEIVED <small>Contractor remains liable for accuracy of submittals as provided in the contract document.</small>	ENGINEER'S ACTION (See Contract Documents)
	A _____
	B _____
	C _____
	D _____
	E _____
	F _____
	G _____

Review status designations listed on Engineer's action stamp are defined as follows:

A - SUBMITTAL ACCEPTED

Signifies equipment or material represented by the submittal conforms with the design concept and complies with the intent of the Contract Documents and is approved for incorporation in the Work. Contractor is to proceed with fabrication or procurement of the items and with related work. Copies of the submittal are to be transmitted to Engineer for final distribution.

B - SUBMITTAL ACCEPTABLE AS NOTED (RESUBMIT)

Signifies equipment or material represented by the submittal conforms with the design concept and complies with the intent of the Contract Documents and is approved for incorporation in the Work in accordance with Engineer's notations. Contractor is to proceed with the Work in accordance with Engineer's notations and is to submit a revised submittal responsive to notations marked on the returned submittal or written in the letter of transmittal.

1-2 ADMINISTRATIVE MATTERS: continued

C - SUBMITTAL RETURNED FOR REVISION (RESUBMIT)

Signifies equipment or material represented by the submittal appears to conform with the design concept and comply with the intent of the Contract Documents but information is either insufficient in detail or contains discrepancies which prevent Engineer from completing his review. Contractor is to resubmit revised information responsive to Engineer's annotations on the returned submittal or written in the letter of transmittal. Fabrication or procurement of items represented by the submittal and related Work is not to proceed until the submittal is acceptable.

D - SUBMITTAL NOT ACCEPTABLE (SUBMIT ANEW)

Signifies equipment or material represented by the submittal does not conform with the design concept or comply with the intent of the Contract Documents and is disapproved for use in the Work. Contractor is to submit compliance submittals responsive to the Contract Documents.

E - PRELIMINARY SUBMITTAL

Signifies submittals of such preliminary nature that a determination of conformance with the design concept or compliance with the intent of the Contract Documents must be deferred until additional information is furnished. Contractor is to submit such additional information to permit layout and related activities to proceed.

F - FOR REFERENCE, NO ACCEPTANCE REQUIRED

Signifies submittals which are for supplementary information only; pamphlets, general information sheets, catalog cuts, standard sheets, bulletins and similar data, all of which are useful to Engineer or Owner in design, operation, or maintenance, but which by their nature do not constitute a basis for determining that items represented thereby conform with the design concept or comply with the intent of the Contract Documents. Engineer reviews such submittals for general content but not for substance.

G - DISTRIBUTION COPY (PREVIOUSLY ACCEPTED)

Signifies submittals which have been previously accepted and are being distributed to Contractor, Owner, Resident Project Representative and others for coordination and construction purposes.

I. Transmittal of Test Reports: Responsibilities of Contractor, Owner and Engineer regarding tests and inspections of equipment, materials, and completed Work are set forth in the Bid Documents. The party specified responsible for testing or inspection shall in each case, unless specified otherwise, arrange for the testing laboratory or reporting agency to distribute inspection and test reports and certificates as follows:

Owner.....	2 copies
Engineer.....	2 copies
Resident Project Representative.....	1 copy
Contractor.....	2 copies
Manufacturer or supplier.....	1 copy

1-2 ADMINISTRATIVE MATTERS: continued

- J. Information to Manufacturer's District Office: Manufacturers and suppliers of equipment or materials shall furnish copies of all agreements, drawings, specifications, operating instructions, correspondence and other matters associated with this Contract to the manufacturer's district office servicing the Owner. Insofar as practicable, all business matters relative to equipment and materials included in this Contract shall be conducted through such local district offices.
- K. Shipment Schedules: Shipment of equipment and materials shall be coordinated with the Work progress schedule to eliminate the necessity for long periods of storage at the site.
- L. Contract Price Breakdown: In addition to the schedule of values prepared and submitted as the basis for partial payments, Contractor shall prepare a separate Contract Price breakdown suitable for Owner's accounting purposes. It shall be submitted to Engineer prior to final payment.
- M. Copies of Documents:
1. Contractor will be provided at no cost to him a maximum of twelve (12) sets of full-size Contract Drawings including revised drawings, and a maximum of fifteen (15) sets of the Bid Documents in addition to those used in execution of the Agreement.
 2. Additional copies of above documents will be supplied at printing and delivery cost upon request.

1-3 CONSTRUCTION PROCEDURES AND SCHEDULES:

- A. Procedures: Construction procedures shall be determined by Contractor subject to Owner's need for continuous operation of existing facilities. The Work is adjacent to existing facilities and the Contractor shall exercise caution and schedule operations to insure that functioning of present facilities will not be endangered. Shutdown of Owner's operating facilities to perform the Work shall be held to a minimum length of time and shall be coordinated with Owner who shall have control over the timing and schedules of such shutdowns.
- B. Scheduled Events: Contractor shall schedule the Work to conform to the events and dates specified as follows:
1. The Contractor shall have all grading, embankment fencing, and structures completed by July 1, 1979.
 2. The Contractor shall have the railroad embankment completed by December 1, 1978 at the following locations:
 - a. From Sta. 77+70.17 to Sta. 93+50.58 Coal Loop.
 3. The Contractor shall have the settling and process waste pond liners installed by December 1, 1979 with the material being supplied from clay in stockpile area.
 4. Guardhouse, gates (26' gate and personnel gate at guard house plus 24' gate at Compress Road and Road "D" intersection), security fencing and temporary fencing located in Cooling Tower area from coordinates N10, 599.5 E 11586.28 to and including 24' electric swing gate at Compress Road shall be installed and completed by November 1, 1978.
 5. Cooling Tower basin shall be completed by March 1, 1979.

1-3 CONSTRUCTION PROCEDURES AND SCHEDULES: continued

- C. Owner's Use of Completed Work: Owner intends to place in service, in accordance with the provisions for use of completed Work set forth in the General Conditions, the following facilities as soon as they are sufficiently complete and ready for their intended use:
1. Railroad loop and access spurs.
 2. Plant roads.
 3. Guardhouse and gates.
- D. Connections to Existing Facilities: Unless otherwise specified or indicated, Contractor shall make all necessary connections to existing facilities including structures, drain lines and utilities such as water, sewer, telephone and electric. He shall in each case notify the owning utility prior to undertaking connections to their facilities unless otherwise authorized by Engineer to proceed. Connections shall be made in the following manner:
1. Verify all measurements for such connections on the site.
 2. Protect breached facilities against the intrusion of deleterious substances and against damage.
 3. Where existing facilities are in service and outages are significant, all activities pertaining to the connections will be thoroughly planned in advance and all equipment, materials and labor required therefor will be on hand at the time of undertaking such connections. Arrangements will be made to work continuously around the clock if necessary to complete connections within the minimum time.
- E. Underground Obstructions:
1. Underground obstructions known to Engineer are indicated on the Contract Drawings. The locations and elevations thereof are generally correct but are not guaranteed. Service lines to individual structures or residences are not indicated. Contractor shall notify owning utilities of his approach to any of their facilities and conform to their requirements.
 2. Contractor shall perform exploratory operations as necessary to verify the location, elevation and dimensions of all known or suspected underground obstructions ahead of any Work affected thereby, and shall use care to avoid damage to them.
 3. Any underground obstructions not indicated on the Contract Drawings and which could not be reasonably anticipated by Contractor will be relocated or removed and replaced by the owning utility at no expense to Contractor, or by Contractor if so instructed by Engineer, in which case a Contract Modification will be issued to cover the additional cost.

1-4 SHIPMENT OF EQUIPMENT AND MATERIALS:

- A. Preparation: Contractor shall require manufacturers and suppliers to prepare equipment and materials for shipment in a manner to facilitate unloading and handling, and to protect against damage or unnecessary exposure in transit and storage. Provisions for protection shall include the following:
1. Covers and other means to prevent corrosion, moisture damage, mechanical injury and accumulation of dirt in motors, electrical equipment and machinery.

1-4 SHIPMENT OF EQUIPMENT AND MATERIALS: continued

2. Suitable rust-preventive compound on exposed machined surfaces and unpainted iron and steel.
 3. Grease packing or oil lubrication in all bearings and similar items.
- B. Marking: Each item of equipment and material shall be tagged or marked as identified in the delivery schedule or on Compliance Submittals and complete packing lists and bills of material shall be included with each shipment. Each piece of every item need not be marked separately provided that all pieces of each item are packed or bundled together and the packages or bundles are properly tagged or marked.

1-5 INFORMATION REGARDING THE SITE:

A. Availability of Lands:

1. Construction office, warehouse and storage areas have been assigned by the Engineer.
2. Confine operations to the area within the limits of the property. Cooperate with the Engineer, Owner and other contractors to maintain the project site in a well-ordered and neat condition.
3. Coordinate delivery of materials with construction program so that an undue amount of storage space is not required. Unloading, storage and working space for the Contractor's use will be designated by the Engineer as close to the work as practicable.

B. Available Facilities:

1. Railroad Spur: The site is served by spur tracks of the Missouri Pacific and the Frisco railroads.
2. Access Roads: The site is served by State Highway 60 and County Road BB with access to Interstate Highway 55 by way of Highway 60.
3. Parking Areas: Parking areas for all construction personnel will be provided by the Owner. The Contractor shall enforce the use of these facilities by his construction personnel in accordance with parking procedures established by the Engineer.

1-6 OPERATIONS ON THE SITE:

A. Conduct of Work:

1. Contractor shall conduct the Work in a manner to avoid unnecessary noise, dust and dirt.
2. Owner's existing plant is in continuous operation, which will require all workers employed in connection with the Work on Owner's property to confine their activities to the designated Work areas. Persons under Contractor's control shall in no way interfere with Owner's plant personnel or disrupt operation of the plant.
3. Contractor shall cooperate with other occupants of the site for efficient utilization of available space.

1-6 OPERATIONS ON THE SITE: continued

B. Construction Offices:

1. Contractor shall provide a field office with telephone service and other necessary utilities which shall be his superintendent's headquarters for supervising Work at the site. It shall be located as directed by the Resident Project Representative.

C. Storage of Equipment and Materials:

1. Contractor shall provide all temporary buildings or trailers needed for storage of equipment and materials installed under this Contract (including those furnished by Owner or others under separate contract) which require indoor storage at the site prior to their installation. Temporary buildings and trailers and stored materials shall be located as directed by the Resident Project Representative, and will be removed when the Work is completed.
2. Engineer shall be advised of any arrangements made for storage of equipment or materials in a place other than Owner's site, and evidence of insurance coverage shall be furnished with any application for payment therefor in conformance with the General Conditions.
3. Contractor shall assume responsibility for and protect all equipment and materials during the storage period in accordance with the manufacturer's or supplier's recommendations including the following:
 - a. Protection of motors, conditioners, electrical equipment, plumbing fixtures, and machinery of all kinds against corrosion, moisture deteriorations, mechanical injury and accumulation of dirt or other foreign matter.
 - b. Protection of exposed machined surfaces and unpainted iron and steel as necessary with suitable rust-preventive compounds.
 - c. Protection of bearings and similar items with grease packing or oil lubrication.
 - d. Handling and storing of steel plate, sheet metal work and similar items in a manner to prevent deformation.
4. Equipment and materials shall not show any pitting, rust, decay, or other deleterious effects of storage prior to final acceptance of Work.

D. Receipt and Unloading of Equipment and Materials Furnished by Others:

1. The equipment contractors will mail duplicate bills of material to Engineer's Kansas City Office and to Resident Project Representative's office at the jobsite prior to the delivery of each shipment of equipment or material.
2. Contractor shall receive, check, unload, inventory, accept and store all equipment and materials delivered to the site in accordance with proper notice. He shall report any damage to Engineer prior to or during unloading and advise Engineer of any shortage at time of delivery. Engineer will verify such reports and so notify the equipment contractor.
3. Contractor shall be responsible for proper location of railroad cars for unloading, any additional switching operations required, and all demurrage charges and substantiated claims for damage to cars or trucks resulting from unloading operations.

1-6 OPERATION ON THE SITE: continued

4. Items furnished by others for installation under this Contract will be delivered to the site complete with packing lists and bills of material. Contractor shall furnish receipts to shipper upon delivery.

E. Temporary Facilities:

1. Electrical Service:

- a. Construction power will be provided by the Owner at no cost to the Contractor. A 460-volt, 3-phase source will be available for connection by Contractor.
- b. The Contractor shall provide all necessary temporary lighting, wiring, panelboards, switches and other devices, with sufficient outlets so that a 50-foot-long extension cord will reach all operations requiring light or power, and include proper overcurrent protection on all conductors of the temporary system.
- c. Lighting shall be as required for construction operations, safety, and security of Contractor and his Subcontractor during the entire construction period. Temporary light shall be based on a minimum of 5 foot candles for floor area, with adequate lighting in all stair wells and corridors to meet safety requirements. The materials used for temporary service shall not be used in the permanent system unless acceptable to Engineer.
- d. Temporary service and light circuits shall be moved as required to maintain progress in the Work and all temporary facilities shall be removed upon completion of the Work.

2. Water: Contractor shall furnish and maintain all connections, conduits and devices needed for his and his Subcontractor's water service. Owner will provide water at the source in reasonable quantities at no cost to the Contractor.

3. Sanitary Facilities: Contractor shall provide and enforce the use of acceptable sanitary facilities for all his construction workers and field representatives at the site. Toilets shall be of the chemically treated type obscured from public view and properly maintained if connection to the plant waste system is unfeasible.

4. Telephone: Contractor shall make necessary arrangements and obtain installation of telephones in Contractor's offices and assume all responsibility for telephone service.

5. Gas: None available.

6. Heat:

- a. Contractor shall provide cold-weather protection and temporary heat when temperature falls below 40 degrees F as required to protect all Work, equipment and materials against injury from dampness and cold, to dry out the building, or to provide proper conditions for the installation and curing of materials.
- b. Method of heating and fuel shall be suitable for the particular purpose. Combustion-type heaters shall be properly vented. No electric resistance heaters or air conditioning units will be permitted on the site except for use in the Contractor's field office.

1-6 OPERATIONS ON THE SITE: continued

F. Maintenance and Use of Roadways:

1. Contractor shall make adequate provisions to prevent unnecessary interference with the use of public and private roads, walkways, drives and parking lots. He shall provide and maintain suitable detours or other temporary expedients if necessary.
2. Contractor shall repair roads, walkways and other traffic areas damaged by his operations. He shall keep traffic areas as free as possible of excavated materials and maintain them in a manner to eliminate dust.
3. Contractor shall provide traffic barricades, construction signs, warning lights, guards, and all other devices and services necessary to adequately protect the public and other contractors.
4. Where necessary, personnel shall be employed by Contractor to direct traffic through construction areas.
5. Bridging over open trenches shall be provided where necessary to maintain traffic.
6. All operations shall meet the approval of the Resident Project Representative who has jurisdiction over walkways and traffic areas.

G. Maintenance of Railroad Service:

1. Contractor shall schedule operations and exercise care to avoid any interruption to continuous service over the railroads within or adjacent to the Work area.
2. Before transporting materials or equipment across railroad tracks or performing Work within any railroad right-of-way, Contractor shall obtain permission or any necessary permits from the railroads, or, in the case of the on-site spur, from the Owner. Permits for pipe or duct banks required to be installed beneath the railroad shall be obtained by Owner.
3. The Work shall be subject to all supervision, inspection, and other conditions required by the affected railroads such as track crossings and watchman service.

H. Signs: All signs of Contractors shall be placed in appropriate locations where they will not obstruct traffic or construction operations. They shall be removed upon completion of the Work.

I. Fire Protection:

1. Contractor shall be responsible for development of a temporary fire prevention and protection program for all his Work at the site.
2. The program shall comply with the applicable provisions for safety and protection set forth in the General Conditions and with applicable parts of the National Fire Protection Association Bulletin No. 241, Building Construction Operations.
3. Should construction fires occur, all equipment provided under this and other contracts shall be used effectively to control and extinguish the fire regardless of the cause, and all personnel at the construction site shall be directed by all contractors to assist in fighting the fires prior to and after arrival of the local fire department personnel.

1-6 OPERATIONS ON THE SITE: continued

J. Cleaning Up:

1. Contractor shall keep the premises free at all times from accumulations of waste materials and rubbish caused by construction operations of all contractors on the site during this contract period. His responsibilities shall include:
 - a. Adequate trash receptacles about the site, emptied promptly when filled.
 - b. Periodic cleanup to avoid hazards or interference with operations at the site and to maintain the site in a reasonably neat condition.
 - c. The keeping of construction materials such as forms and scaffolding neatly stacked.
 - d. Immediate cleanup to protect the Work by removing splattered concrete, asphalt, oil, paint, corrosive liquids and cleaning solutions from walls, floors and metal surfaces before surfaces are marred.
2. Contractor shall perform final cleanup prior to Owner's acceptance of the Work. His final cleanup shall include:
 - a. Removal of dirt and unsightly substances from all visible surfaces and areas.
 - b. Removal of deleterious substances from all parts of the Work.
 - c. Washing of all windows in parts of buildings affected by Contractor's operations.
 - d. Inside work "broom-clean" or its equivalent.
 - e. Surfaces to be painted under other contracts in a condition requiring only the use of rags and solvents to prepare surfaces for paint.
 - f. Removal of Contractor's temporary structures, tools, equipment, supplies and surplus materials.
 - g. Repair of roads, walks, fences and other items damaged or deteriorated because of Contractor's operations.
 - h. Grading, raking, smoothing, replacing vegetation and other operations necessary to restore to original or better condition all areas affected by Contractor's operations.
 - i. Disposal of waste material off site according to local and state requirements.

1-7 STIPULATIONS REGARDING PROPERTY OF OWNER AND OTHERS:

A. Use of Owner's Equipment:

1. Use of any plant equipment, whether furnished and installed under this Contract or not, including elevator, shop crane, heating, ventilating, air-conditioning, and plumbing fixtures, will not be allowed except by written permission from Owner.

- B. Dust and Weather Barriers: Contractor shall protect existing equipment and materials and structures against any injurious effects of dust and weather with barriers constructed of plywood, hardboard, plastic, or similar material, and adequately braced and anchored against weather elements. All barrier attachments to an existing structure shall be of a nature to avoid damage to the structure.

1-7 STIPULATIONS REGARDING PROPERTY OF OWNER AND OTHERS: continued

C. Protection of Existing Property:

1. Contractor shall provide for the safety and protection of existing property as set forth in the General Conditions. Any damage to existing facilities resulting from construction operations shall be reported immediately to the owners thereof and promptly repaired by Contractor.
2. Names and telephone numbers of representatives of agencies and utilities having jurisdiction over or operating streets and utilities in the Work area can be obtained from resident Engineer. Concerned parties shall be contacted a minimum of twenty-four (24) hours prior to cutting or closing streets or other traffic areas or excavating near underground utilities or pole lines.
3. Operation of valves or other appurtenances on existing utilities, when required, shall be under the direct supervision of the owning utility.
4. Where fences are to be breached on private property, the owners thereof shall be contacted and arrangements made to insure proper protection of any livestock or other property thus exposed.
5. The applicable requirements specified for protection of the Work shall also apply to the protection of existing property.
6. Before acceptance of the Work by Owner, Contractor shall restore all property affected by his operations to the satisfaction of the property owners.

D. Protection of the Work:

1. Contractor shall provide for the safety and protection of the Work as set forth in General Conditions. He shall provide protection at all times against rain, wind, storms, frost, freezing, condensation or heat so as to maintain all Work, equipment, and materials free from injury or damage. At the end of each day all new Work likely to be damaged shall be covered.
2. Engineer shall be notified immediately at any time operations are stopped due to conditions which make it impossible to continue operations safely or to obtain proper results.
3. Contractor shall construct and maintain all necessary temporary drainage and do all pumping necessary to keep excavations and floors, pits and trenches, manholes and ducts free of water.
4. Floors shall be protected from damage by proper covering and care when handling heavy equipment, painting, or handling mortar or other such materials, and proper cribbing and shoring shall be used to prevent overloading of floors while moving heavy equipment. He shall provide metal pans under pipe-threading machines and clean such pans daily, keep oil off floors and restore floors to former condition where damaged or stained.
5. Concrete floors less than twenty-eight (28) days old shall not be loaded without written permission from Engineer.
6. Contractor shall restrict access to new roofs and keep clear of existing roofs, except as required by the Work. Where access is required he shall provide protection with plywood, boards or other suitable materials.

1-7 STIPULATIONS REGARDING PROPERTY OF OWNER AND OTHERS: continued

7. Protection of Sample Well:

Contractor shall protect sample well as approximately located at coordinates N 10250 and E 12790 from damage during construction. Protection shall be by extending existing 2-inch diameter steel casing as required to maintain the top of the casing a minimum of 2--feet above the working grade, keeping casing capped at all times except during sampling and other measures as required by Engineer to insure safety of well.

E. Traffic Regulations:

1. Traffic signs shall be installed for railroad crossing and at necessary locations to detour traffic on Compress Road during construction. Signs shall conform to construction zones and railroad crossing specified by "Manual of Uniform Traffic Control Devices" (MUTCD).
2. Flagmen as needed to safely direct vehicular and human traffic.
3. Flares and lights as required by MUTCD.
4. Parking that may interfere with traffic flow on Compress Road is prohibited.

1-8 MANUFACTURER'S FIELD SERVICES:

A. Services with Equipment and Materials Furnished Under This Contract:

1. Contractor shall furnish the services of qualified field personnel (from the manufacturers and suppliers of equipment and materials furnished and installed under this Contract), as required to perform all manufacturers' and Contractor's field services called for in the Specifications.
2. He shall perform no work related to the installation or operation of equipment or materials furnished and installed under this Contract without direct observation and guidance of the supplier's or manufacturer's field personnel (where such service is specified) unless Engineer concurs otherwise.
3. The supplier's or manufacturer's and Contractor's field personnel shall perform the following:
 - a. Observe the erection, installation, startup and testing of equipment.
 - b. Instruct and guide Contractor in proper procedures.
 - c. Supervise the initial startup, operational check, and any required adjustments of equipment.
 - d. Instruct Owner's designated personnel in proper operation and maintenance of all equipment.
4. All supplier's and manufacturer's and Contractor's field personnel are to advise Engineer of their arrival at the site and furnish to him a written report covering all Work done at least once each week and when completed.
5. Pumping from Sample Well:
 - a. Contractor shall furnish, install and operate a 20 gpm minimum centrifugal pump to obtain samples from sample well.
 - b. Pump suction pipe can be installed inside 2-inch diameter threaded steel casing or can be directly connected to top of pump casing.
 - c. Samples shall be taken at approximately 30 day intervals on week days as selected by the Engineer.

1-7 STIPULATIONS REGARDING PROPERTY OF OWNER AND OTHERS: continued

- d. During sampling periods, Contractor shall install and operate pump for 24 consecutive hours.
- e. Contractor shall assist Engineer as required in order for proper sampling and to determine pump flow rate.
- f. Samples will be collected by Engineer at 8, 16, and 24 hours after pumping commences.
- g. Contractor shall keep a log of pump start and stop and of any times during which the pump was not running within the 24 hour pumping period.

B. Placing Equipment in Operation:

- 1. Contractor shall place all equipment and materials installed under this Contract (including those furnished by Owner or others under separate contract) into successful operation according to instructions of the supplier or manufacturer (or Field Representative), including making of all required adjustments, tests, operation checks and the following:
 - a. Cleaning, sounding, blowing-out, flushing of lubricating oil and water systems and other pipelines.
 - b. Lubrication (lubricants supplied by Owner unless specified to be furnished by others).
 - c. Tests of lubrication system safety interlocks and system performance.

1-8 MANUFACTURER'S FIELD SERVICES: continued

- d. Final alignment checks and measurements made under observation of Engineer and Owner. Alignment checks shall include opening connections if required to insure there are no abnormal stresses on equipment from pipes, ducts or other attachments. Alignment shall be within tolerances specified by the manufacturer, and measurements shall be recorded and furnished to Engineer.
 - e. Motor rotation checks before connecting couplings.
 - f. Inspection of sleeve bearings for adequate contact. Include scraping bearings for at least eighty-percent (80%) contact and demonstrating contact area to Owner and Engineer before final assembly of bearing caps.
 - g. Checking of anchor-bolt tensions, grout and shims. Anchor bolts shall be tightened with calibrated torque wrenches using care not to overstress bolts.
2. After run-in and acceptance of alignment, major equipment shall be affixed in place using standard tapered dowels with jack-out nuts at head end to facilitate removal.
 3. All above operations shall be recorded on forms furnished by Engineer.
 4. All necessary attendants and personnel shall be furnished as part of the work to accomplish the above operations until such time as individual items, systems, equipment or sections of the plant are acceptable for operation by Owner.
 5. Contractor shall provide attendants on continuous basis as required to complete events, such as blowing out steam lines and initial synchronizing of turbine generators, without interruption once they have been started.
 6. Owner will provide electricity, water, and lubricants for placing equipment in operation, and Owner's operating personnel will assist.

C. Performance Tests:

1. Equipment and Materials Furnished under this Contract:
 - a. Owner may conduct acceptance tests after installation to determine if the equipment and materials installed as part of the Work perform as specified and as guaranteed. Final acceptance of equipment and materials (or Substantial Completion) and start of guarantee period will be based on acceptable results of such tests.
 - b. No tests will be conducted on equipment or materials for which manufacturer's field service is specified unless manufacturer's Field Representative is present and declares in writing that the equipment and materials are ready for such test.
 - c. Contractor will be notified so that he can have a representative, or manufacturer's representative, present during any tests of equipment or materials for which manufacturer's field service is not specified.
 - d. The tests will be made as set forth in the Specifications unless the interested parties mutually agree upon some other manner of testing.

1-9 MEASUREMENT AND PAYMENT:

- A. All Work indicated on the Contract Drawings or specified in the Bid Documents will be considered as included in the lump sum bid price.

1-10 LIST OF DRAWINGS:

- A. Contract Drawings: Each sheet of the Contract Drawings prepared by Engineer as a basis for this Contract bears the following general title:

Yard Drawings

Y28 Site Plan and Vicinity Map
Y29 Road Geometry
Y30 Railroad Geometry, Sheet 1
Y31 Railroad Geometry, Sheet 2
Y32 Unassigned
Y33 Grading Plan, Area I
Y34 Grading Plan, Area II
Y35 Grading Plan, Area III
Y36 Grading Plan, Area IV
Y37 Grading Plan, Area V
Y38 Grading Plan, Area VI
Y39 Grading Plan, Area VII
Y40 Grading Plan, Area VIII
Y41 Grading Plan, Area IX
Y42 Grading Plan, Area X
Y43 Grading Plan, Area XI
Y44 Grading Plan, Area XII
Y45 Road Profiles I
Y46 Road Profiles II
Y47 Road Profiles III
Y48 Railroad Profiles I
Y49 Railroad Profiles II
Y50 Railroad Profiles III
Y51 Railroad Profiles IV
Y52 Railroad Profiles V
Y53 Grading Sections I
Y54 Grading Sections II
Y55 Unassigned
Y56 Typical Sections and Grading Details
Y57 Storm Drainage Details
Y58 Fencing Details
Y59 Miscellaneous Details
Y60 Unassigned

Yard Piping Drawings

UP14 Yard Piping Details I
UP15 Unassigned
UP16 Unassigned

Arichitectoral Drawings

A2 Guardhouse

1-10 LIST OF DRAWINGS: continued

Structural Drawings

- S201 Substation Access Bridge, General Plan and Elevation
- S202 Substation Access Bridge, Abutment and Pier Details
- S203 Substation Access Bridge, Prestressed Concrete Alternate,
Superstructure Details
- S204 Substation Access Bridge, Precast Concrete Alternate,
Superstructure Details
- S205 Coal Yard Runoff Details
- S206 Compress Road Storm Runoff Culvert Plans and Details
- S207 Compress Road Storm Runoff Culvert Plans and Details
- S208 Compress Road Storm Runoff Culvert Plans and Details
- S209 Cooling Tower Plan, Sections, and Details
- S210 Valve Pit, Pipe Support Plan, Sections and Details
Circulating Water Flume Plan, Sections and Details
- S211 Fly Ash Pond overflow structures
- S212 Unassigned

Reference Drawings

- Y11 Grading Plan Area VII
- Y12 Grading Plan Area VIII

* * * * *

DIVISION 2 - SITE WORK

2A SITE PREPARATION AND EARTHWORK

2A-1 GENERAL

A. DESCRIPTION:

1. This Section includes site preparation activities and certain items of earthwork common to other related work as necessary to complete the Work.
2. Related Work Specified Elsewhere:
 - a. Storm Drainage: SECTION 2B.
 - b. Roads, Drives and Surfaced Area Construction: DIVISION 18.
 - c. Seeding: SECTION 2C.
 - d. Temporary Fencing: SECTION 2D.
 - e. Fence and Gates - Security Type: SECTION 2E.
 - f. Foundation Piling: SECTION 2F.
 - g. Concrete: DIVISION 3.

B. QUALITY ASSURANCE:

1. Applicable Standards:
 - a. American Association of State Highway and Transportation Officials Standard Method of Test (AASHTO):
 - (1) T99 - The Moisture-Density Relations of Soils Using a 5.5-Pound (2.5 Kg) Rammer and a 12-Inch (305 mm) Drop.
 - (2) T104 - Soundness of Aggregate by Use of Sodium Sulfate or Magnesium Test.
 - (3) M80 - Coarse Aggregate for Portland Cement Concrete.
 - (4) M147 - Materials for Soil Aggregate.
 - b. American Society for Testing and Materials (ASTM), 1970, 5th Edition Special Procedures for Testing Soil and Rock for Engineering Purposes:
 - (1) D2049 - Relative Density of Cohesionless Soils.
 - (2) ASTM STP479 - Burmister Method.
 - c. U. S. Department of the Interior, Bureau of Reclamation, Earth Manual, 1st Edition:
 - (1) E-12 - Relative Density of Cohesionless Soils.
 - d. Missouri Department of Highways Standard Specifications for Road and Bridge Construction.
2. Field and Laboratory Testing:
 - a. The Owner will retain a qualified testing laboratory to make field and laboratory tests. The Contractor will operate in a manner that permits testing to be performed in a reasonable manner. The Contractor may at his expense retain a testing laboratory that is approved by the Engineer.

C. JOB CONDITIONS:

1. Lines and grades shall be as indicated. Engineer will furnish bench marks, base lines, and reference points as necessary to permit the Contractor to lay out and construct the work properly.
2. Maintain carefully all bench marks, monuments, and other reference points and replace as directed if disturbed or destroyed.
3. Explosives: Blasting will not be permitted.
4. Disposition of Utilities:
 - a. Adequately protect from damage all active utilities and remove or relocate only as indicated or specified.

2A - SITE PREPARATION AND EARTHWORK: continued

- b. Report inactive and abandoned utilities encountered in excavating and grading operations. Remove, plug, or cap as directed.
5. Storm Runoff Retention Ponds:
 - a. Construct at locations outside grading limits as required to collect and retain all storm runoff from areas to be graded and as directed by the Engineer.
 - b. Size ponds to retain the runoff resulting from a 10 year 24 hour storm as calculated by the U.S. Soils Conservation National Service Engineering Handbook and Urban Hydrology for Small Watersheds (Technical Release No. 55).
 - c. Construction of the storm runoff retention ponds shall include the following:
 - (1) Dike, ditches and channels as required to direct all runoff to the retention ponds.
 - (2) Dikes constructed in accordance with the provisions for "Embankment," this section, of sufficient height to prevent overtopping during the wet season.
 - (3) Controlled discharge facilities consisting of pipe culverts, valves, weirs, or other appurtenances approved by the Engineer.
 - (4) Seeding, riprap and slope paving as required to protect dike slopes from erosion.
 - d. Drain ponds in a manner which will prevent sediment from leaving the pond with the discharge. Accomplish as soon as practical after each rainfall.
6. Sediment Traps:
 - a. Sediment traps shall include the following:
 - (1) Sand bags stacked in an interlocking fashion.
 - (2) Wire-tied straw bales anchored to the ground by 2 steel fence posts per bale. Straw bales are to be replaced when rotten or disintegrating.
 - b. Straw bales or sand bags shall be set in a trench excavated to a depth of 6 inches. Upstream face of trench shall be backfilled and tamped to prevent piping.
 - c. Sediment traps shall be cleaned as necessary to prevent clogging.
7. Dikes, silt fences and sediment traps shall be a minimum of 4'-0" in height but shall be of sufficient height to prevent overtopping.
8. Remove sediment when the depth of the sediment reaches 2'-6" and place material in the waste area as directed by the Engineer.

2A-2 EQUIPMENT AND MATERIALS

A. MATERIALS:

1. Materials Encountered:
 - a. All materials encountered, regardless of type, character, composition, and condition thereof, shall be unclassified.
 - b. Excavation shall include all materials found within the designated limits for excavation.
 - c. Determine quantity of various materials to be excavated prior to submitting Bid Form. If encountered, remove rock at no extra cost to Owner.
 - d. Arrangements for entry to site for purpose of conducting subsurface investigations, including test borings, shall be made with Owner.

2A - SITE PREPARATION AND EARTHWORK: continued

- e. Cohesionless materials include gravels, gravel-sand mixtures, sands, and gravelly sands exclusive of clayey and silty material - materials which are free-draining and for which impact compaction will not produce a well-defined moisture-density relationship curve and for which the maximum density by impact methods will generally be less than by vibratory methods.
 - f. Cohesive materials include silts and clays generally exclusive of sands and gravel - materials for which impact compaction will produce a well-defined moisture-density relationship curve.
2. Waste Materials:
- a. Includes excess suitable materials and materials unsuitable for use in the Work.
 - (1) Unsuitable materials include all material that contains debris, roots, organic matter, frozen matter, rock (with any dimension greater than one-half the loose layer thickness) or other materials that are determined by Engineer as too wet or otherwise unsuitable for providing a stable subgrade or stable foundation for structures.
 - (2) Suitable materials include material that is free of debris, roots, organic matter, refuse, ashes, cinders, frozen matter and, which is free of rock with any dimension greater than one-half the specified loose layer thickness.
 - b. Remove unsuitable materials from work area as excavated.
 - c. Keep excess suitable material segregated from unsuitable waste in the disposal area.
 - d. Deposit waste materials in locations and within areas designated by Engineer. The Contractor is responsible for off-site disposal of waste materials at no additional cost to the Owner.
 - e. Grade waste areas and leave them free draining and with an orderly and neat appearance.
 - f. Construct erosion control devices as specified in Section 2A.
3. Borrow Materials:
- a. Refers to all fill materials and topsoil obtained from approved locations either on or off the jobsite.
 - b. Borrow shall include all excavating, handling, and final disposal of materials as specified. Borrow, if required, to bring the embankments to the lines and grades indicated, shall be furnished by the Contractor, as specified, without additional compensation.
 - c. Borrow areas shall be:
 - (1) Arranged for by Contractor at no additional cost to Owner whether on-site or off-site.
 - (2) Subject to approval by Engineer.
 - d. Material removed from borrow areas shall be as approved by Engineer.
 - e. Leave borrow areas graded to drain and to present a neat appearance.
 - f. Topsoil, seed and mulch as specified in SECTION 2A and 2C.
4. Embankment Material:
- a. Includes suitable approved material from excavations and borrow areas.
 - b. Embankment material shall be friable sandy or silty clay containing fine material sufficient to provide a dense mass free of voids and capable of satisfactory compaction.
 - c. Do not use material containing gravel, stones, or shale particles greater in dimension than one-half the depth of the layer to be compacted.

2A - SITE PREPARATION AND EARTHWORK: continued

- d. Material shall be free of roots or other organic matter, refuse, ashes, cinders, frozen earth or other unsuitable material.
- e. Perform any wetting or drying of the material as required to obtain the specified density when compacted and to maintain moisture content at time of placement (to not less than optimum or more than 4 percent above optimum) as determined by AASHTO T99.
- 5. Clay Material Undercut:
 - a. The undercut is indicated to a uniform depth of 36 inches beneath the existing ground surface for the purpose of providing approximate amount. The depth shall be determined during construction by Engineer.
- 6. Trench Stabilization Material: Material shall be as follows:
 - a. As specified for granular fill material, or
 - b. Conform to AASHTO M147, Grading A or B, well graded, with not more than 10% passing No. 200 sieve.
- 7. Granular Fill Material:
 - a. Material shall be crushed rock with the following gradation:

<u>Sieve Size</u> <u>(Square Openings)</u>	<u>Percent Passing</u> <u>(By Weight)</u>
1"	100
3/4"	90-100
3/8"	30-65
No. 4	5-25
No. 8	0-10
No. 16	0-5
 - b. Material shall not have a loss of more than 15% after 5 cycles when tested for soundness with sodium sulfate as described in AASHTO T104.
 - c. Use for the following:
 - (1) Under slabs on grade.
 - (2) Pipe embedment.
 - (3) Trench stabilization.
 - d. Gradation shall not vary from low limit on one sieve to high limit on adjacent sieve or vice versa.
- 8. Topsoil Materials:
 - a. Includes those materials obtained from excavation which are most suitable and stockpiled for such purpose, or
 - b. Borrow when required.
- 9. Riprap Material:
 - a. All stone shall be durable and of suitable quality to insure permanence in the structure and in the climate in which it is to be used.
 - b. Boulders or quarried rock may be used and shall be graded as follows:

<u>Weight in Pounds</u> <u>Per Stone</u>	<u>Percent of Total Weight</u> <u>Lighter Than or Passing</u>
300	100
150	55-75
50	25-45
2-inch screen	5-15

2A - SITE PREPARATION AND EARTHWORK: continued

- c. Quantity of rock with an elongation greater than 3:1 shall not exceed 20 percent of the mass. No stone shall have an elongation greater than 4:1.
- d. Material shall be free from cracks, seams, or other defects that would tend to increase its deterioration from natural causes.
- e. Objectionable quantities of dirt, sand, clay and rock fines will not be permitted.
- f. Not more than 10 percent of the stone shall show splitting, crumbling, or spalling when subjected to 5 cycles of the sodium soundness test as required by AASHTO T104.
- g. Furnish Engineer certification from an approved laboratory that the material conforms to these specifications.
- h. In lieu of conforming to above specified test requirements, material with a proven history of satisfactory performance will be approved for use in the work provided certification of this history is acceptable to the Engineer.

10. Filter Blanket Material:

- a. Material shall conform to the applicable requirements of AASHTO M80 and shall be reasonably well graded within the following limits:

<u>Sieve Sizes</u>	<u>Percent Passing by Weight</u>
4 inch	100
3 inch	80-100
2 inch	70-90
3/4 inch	45-60
No. 4	20-30
No. 10	5-15
No. 40	0-5

- b. Crushed rock may be used as a filter material providing it meets the gradation specified above.

11. Clay Borrow Material (off-site):

- a. Clay material brought in from off-site sources shall exhibit a maximum permeability of 1×10^{-7} cm per second in the compacted state.
- b. Any clayey soil not showing the above stated permeability shall immediately be rejected.

B. EQUIPMENT:

- 1. Compaction equipment shall conform to the following requirements and be subject to the approval of the Engineer.
 - a. Tamping Rollers:
 - (1) Tamping roller may be towed or self-propelled.
 - (2) Rollers shall have staggered uniformly spaced knobs or feet. When fully loaded, they shall exert at least 300 psi on combined area of tamping feet in contact with ground.
 - (3) Rollers shall be equipped with cleaning fingers maintained at full length to prevent accumulation of material between feet.
 - (4) Maintain all equipment in good repair.
 - b. Rubber-tired rollers shall have two axles, not less than 9 wheels with pneumatic tires, a rigid steel frame, and a body suitable for ballast loading.
 - c. Power tampers shall be used for compaction of material in areas where it is impractical or unsafe to use heavy equipment, and as directed by the Engineer.
 - d. Vibratory compactor shall have a steel drum 42 inches in diameter, with a vibrating force of 300 pounds per cycle per inch of drum width and a vibrating frequency of 1,200 cycles per minute.
 - e. Vibratory plate compactor suitable for compacting granular pipe embedment.

2A - SITE PREPARATION AND EARTHWORK: continued

2A-3 PERFORMANCE

A. CLEARING AND GRUBBING:

1. Perform clearing and grubbing where indicated or as necessary to perform excavation, trenching, embankment, borrow and other work required.
2. Clearing:
 - a. Clearing includes felling and disposal of trees, brush, and other vegetation off site.
 - b. Remove existing fence within the limits of clearing. Waste or store as directed by Engineer.
 - c. Conduct work in a manner to prevent damage to property and to provide for the safety of employees and others.
 - d. Keep operations within property lines indicated.
3. Grubbing:
 - a. Removal and disposal of tree stumps and roots larger than 3 inches in diameter.
 - b. Remove to a depth of at least 18 inches below existing grade elevation.
 - c. Backfill all excavated depressions with approved material and grade to drain.

B. DEMOLITION:

1. Remove existing construction to limits indicated, or as required to perform new construction.
2. Materials not indicated or specified to be relocated or returned to Owner shall be disposed of as specified in "Disposal of Debris" this section.
3. Perform demolition work to protect existing facilities, structures and property, which are to remain, against damage from operations, falling debris, or other cause.
4. Make provisions for temporarily accommodating flows in existing facilities to be relocated or disturbed.
5. Take precautions to guard against movement or settlement, and provide shoring and bracing as necessary.
6. If at any time safety of existing structure to remain is endangered, cease operations, notify Engineer and do not resume operations prior to approval.
7. Remove concrete by jack hammering, sawing, core drilling, or other approved method.
8. Carefully dismantle, in a manner to avoid damage, all materials and equipment indicated to be relocated or returned to Owner.
9. Store materials and equipment to be reused in a manner to avoid corrosion, staining, breakage, or damage from any cause.
10. Any of the material or equipment, specified or indicated to be relocated or returned to the Owner, that is damaged due to Contractor's negligence shall be repaired or replaced, as determined by the Engineer, at the Contractor's expense.
11. Remove existing asphaltic pavement by jack hammering, sawing, scarifying or other approved methods except as follows:
 - a. Existing asphaltic pavement shall be sawed at point where pavement indicated to remain ends and pavement indicated to be removed begins.

2A - SITE PREPARATION AND EARTHWORK: continued

C. DISPOSAL OF DEBRIS:

1. Dispose of debris from clearing and grubbing and demolition at a location off the jobsite as arranged for by Contractor.
2. Contractor may claim and salvage any timber or other debris which he may consider of value, but shall not delay in any manner either this contract or other work with salvaging operations.
3. Combustible waste material and debris may be burned subject to the Contractor obtaining all required permits and conducting all burning operations in strict accordance with applicable regulations. Dispose of wastes at a location off the jobsite as arranged by the Contractor.

D. STRIPPING:

1. Remove topsoil from areas within limits of excavation, trenching, borrow and areas designated to receive embankment and compacted fill.
2. Scrape areas clean of all brush, grass, weeds, roots and other materials.
3. Strip to a minimum depth of 6 inches, but to a sufficient depth to remove excessive roots in heavy vegetation or brush areas and as required to segregate topsoil.
4. Stockpile topsoil in areas designated where it will not interfere with construction operations or existing facilities. Stockpiled topsoil shall be reasonably free of subsoil, debris, and stones larger than 2-inch diameter.
5. Dispose of waste on the site at locations as approved by the Engineer.

E. SHEETING AND BRACING:

1. Requirements:
 - a. Use as necessary to conform with the following:
 - (1) Federal and state laws and local ordinances.
 - (2) To protect life, property and the work.
 - (3) To avoid excessively wide cuts in unstable material.
 - b. Use is mandatory where construction is adjacent to existing buildings and utilities and where sloped side walls would extend beyond construction right-of-way.
2. Approved Materials:
 - a. Provide on site prior to start of excavation in each section, and make such adjustments as are required to meet unexpected conditions.
 - b. Space and arrange sheeting and bracing as required to exclude adjacent material and according to the stability of excavation slopes.
 - c. Remove simultaneously with backfilling, except as otherwise approved, and fill voids left after withdrawal with sand or other approved material.
 - d. Leave in place when required by conditions of supported material and cut off at approved elevation below the surface.
 - (1) No higher than one foot below finished surface grade, and
 - (2) No lower than one foot above top of buried pipe or conduits.

F. DEWATERING:

1. Control grading around excavations to prevent surface water from flowing into excavation areas.

2A - SITE PREPARATION AND EARTHWORK: continued

2. Drain or pump as required to continually maintain all excavations and trenches free of water or mud from any source, and discharge to approved drains or channels. Commence when water first appears and continue until work is complete to the extent that no damage will result from hydrostatic pressure, flotation, or other causes.
3. Use pumps of adequate capacity to insure rapid drainage of area, and construct and use drainage channels and subdrains with sumps as required.
4. Install adequate sumps, wellpoints, or wells to lower ground water table to provide a stable work area during construction.
5. The Contractor is to obtain the services of a qualified dewatering expert to provide a dewatering plan as might be necessary for work under this contract.
6. Remove unsuitable excessively wet subgrade materials and replace with approved backfill material.
7. The Contractor shall submit dewatering plan to the Engineer as part of the Compliance Submittals.

G. STOCKPILING:

1. Stockpile in amounts sufficient for and in a manner to segregate materials suitable for the following:
 - a. Topsoiling.
 - b. Constructing embankments and fills.
 - c. Backfilling.
 - d. Waste only.
 - e. Clay lining.
2. Do not obstruct or prevent access to the following:
 - a. Roads and driveways.
 - b. Utility control devices.
 - c. Ditches or natural drainage channels.
 - d. Transmission towers.
3. Perform in a manner to avoid endangering the work, stability of banks or structures, or health of trees and shrubs to be saved.
4. Maintain safe distance between toe of stockpile and edge of excavation or trench.
5. Stockpile in other areas or off site when adjacent structures, easement limitations, or other restrictions prohibit sufficient storage adjacent to the Work. Off-site areas shall be arranged for by Contractor at no additional cost to Owner.

H. COMPACTION:

1. Compact subgrades, fills, embankments and backfills using spreading equipment, tamping rollers, rubber-tired rollers, vibratory compactors, or power tampers, as required to obtain reasonable uniformity.
2. Perform within moisture content range as specified to obtain required results with equipment used.
3. Achieve minimum densities specified as referenced to:
 - a. Cohesive soils - 95% maximum density at optimum moisture, AASHTO T99.
 - b. Cohesionless soils - 70 percent relative density.
 - (1) ASTM, STP 479 burmister method.
 - (2) USBR - E12 Relative density.
 - (3) Relative density, ASTM D2049.

I. SITE GRADING:

1. Excavate, fill, compact fill, and rough grade to bring project area to subgrades as follows:

2A - SITE PREPARATION AND EARTHWORK: continued

- a. For surfaced areas, to underside of respective surfacing or base course.
 - b. For seeded areas, ditches and slopes 2:1 and greater, as indicated on grading sections.
 2. Rock:
 - a. If encountered in grading areas outside of buildings, the provisions contained herein shall apply.
 - b. Backfill to grade, with earth compacted in place after removing rock to depths as follows:
 - (1) Under surfaced areas, to 6 inches below the top of respective subgrades for such areas.
 - (2) Under planted areas to 24 inches below finished grade except that boulder or protruding rock outcrop, if so indicated, shall be left undisturbed.
 3. Fill:
 - a. Fill as required to raise existing grades to the new grades as indicated.
 - b. Perform as specified in "EMBANKMENT," this Section.
 - c. Remove all debris subject to termite attack, rot, or corrosion from areas to be filled.
 4. Rough Grading:
 - a. Grade and compact all areas within the project, including excavated and filled sections, and adjacent transition areas reasonably smooth and free from irregular surface changes.
 - b. Degree of finish shall be that ordinarily obtained from blade grader or scraper operations, except as otherwise specified.
 - c. Finished rough grades shall generally be not more than 0.25-foot above or below established grade or approved cross sections with due allowance for topsoil.
 - d. Tolerance for areas within 10 feet of (future) building shall not exceed 0.15-foot above or below established subgrade.
 - e. Finished subgrades for roads, drives and surfaced areas shall not be lower than indicated, nor higher than 0.1-foot above that indicated.
 - f. Finish all ditches, swales, and gutters to drain readily.
 - g. Unless otherwise indicated, slope the subgrade evenly to provide drainage away from (future) building walls in all directions at a grade not less than $\frac{1}{4}$ -inch per foot.
 - h. Provide roundings at top and bottom of banks and at other breaks in grade.
- J. EXCAVATION:
1. General:
 - a. Perform excavation by any recognized method of good practice to complete the job in the most expeditious manner.
 - b. Take precautions to insure no damages to existing facilities or equipment, or other work.
 2. Trenching:
 - a. Extent of Work:
 - (1) Includes excavation, sheeting, bracing and all operations necessary for the preparation of trenches for bedding of pipes and all appurtenances thereto.

2A - SITE PREPARATION AND EARTHWORK: continued

- (2) Remove material as required for alignment and elevation of work as indicated.
- (3) Dewater as specified in SECTION 2A.
- b. Equipment and Methods:
 - (1) Types of equipment and methods may be at Contractor's option, where structures or other facilities are not endangered.
 - (2) Equipment and methods shall be subject to approval of jurisdictional agency where stability or usefulness of other facilities may be impaired.
 - (3) Perform by hand methods when required to save culverts, utilities or other structures above or below ground.
 - (4) Maximum length of open trench shall be limited as necessary to conform to local codes.
- c. Side Walls:
 - (1) Make vertical below top of pipe.
 - (2) Make vertical or sloped from a plane 12 inches above top of pipe down to top of pipe.
 - (3) Make vertical or sloped as required for stability, above a plane 12 inches above top of pipe.
 - (4) Sheet and brace where necessary.
 - (5) Excavate without undercutting.
- d. Trench Depth:
 - (1) Depth shall be sufficient to provide the minimum bedding requirements for the pipe being placed.
 - (2) Do not exceed depth indicated where conditions of bottom are satisfactory.
 - (3) Increase depth as necessary to remove unsuitable supporting materials.
- e. Trench Bottom:
 - (1) Protect and maintain when suitable natural materials are encountered.
 - (2) Remove rock fragments and materials disturbed during excavation or raveled from trench walls.
 - (3) Restore to proper subgrade with granular fill material or compacted backfill as approved by the Engineer.
- f. Trench Stabilization: Compact in lifts not exceeding 6 inches to approved firm condition with pneumatic or vibratory equipment.
- g. Trench Width:
 - (1) Excavate trench to a minimum width which will permit satisfactory jointing of the pipe and thorough tamping of bedding.
 - (2) Maintain trench widths below a plane 12 inches above top of pipe as follows:

<u>Nominal Pipe Size</u>	<u>Trench Width</u>	
	<u>Minimum</u>	<u>Maximum</u>
Less than 24"	Pipe od + 1'	Pipe od + 2'
14" to 60"	Pipe od + 2'	Pipe od + 4'

- (3) Maximum trench width limitations shall apply beginning 3 feet from manhole or structure walls.
- (4) Maximum width shall be as near the minimum specified as can be controlled by construction equipment and methods utilized.
- (5) Correct when overexcavated at no additional cost to the Owner.
 - (a) Use stronger pipe or higher class embedment.
 - (b) Obtain approval of Engineer before proceeding.

2A - SITE PREPARATION AND EARTHWORK: continued

- h. Trenching Under Existing Utilities: The pipe trench walls shall be maintained vertical under existing duct banks and other utilities. This shall be accomplished by driving steel H-section beams each side of the utility and placing timber lagging between the beams. All excavation under utilities shall be by hand methods.
 - i. Trenching Across Drainage Ditches: Open cuts through existing drainage ditches shall be provided with protection from flows entering the trench. Methods of blocking and disposing of flows shall be by methods as approved by the Engineer.
 - j. Test Pits:
 - (1) Excavate test pits sufficiently in advance of trenching to enable adequate planning of construction procedure.
 - (2) Locate as follows:
 - (a) Where unstable material is suspected that may require special protective measures.
 - (b) Where ground water may require special handling methods.
 - (c) Where indicated or otherwise approved.
 - (d) Where interference or conflict with other utilities or structures could affect alignment of pipe.
 - (e) Where advisable to assess adequacy of blasting pattern.
 - (3) With lateral dimension not less than minimum trench width specified for location excavated.
 - (4) To depth required to obtain information desired.
 - k. Fill Areas: Perform trenching in fill areas only after compacted fill has reached an elevation of not less than one foot above the top of the pipe.
3. Structures: Perform as specified for "Trenching," and as follows:
- a. Excavate area adequate to permit efficient erection and removal of forms.
 - b. Trim to neat lines where details call for concrete to be deposited against earth.
 - c. Excavate by hand in areas where space and access will not permit use of machines.
 - d. Notify Engineer immediately when excavation has reached the depth indicated. Do not proceed further until approved.
 - e. Restore bottom of excavation to proper elevation in areas overexcavated, as follows:
 - (1) For structures supported by caissons, with compacted embankment.
 - (2) For structures supported by footings, with concrete.

K. BACKFILLING:

- 1. Trenches: Perform as specified for "Embankment," this section, with the following additional provisions:
 - a. Complete promptly after approval to proceed.
 - (1) Upon completion of pipe embedment.
 - (2) Only after concrete encasement (when required) has attained 70 percent of design strength.
 - b. Use hand methods to a plane 12 inches above top of pipe.
 - c. Use approved mechanical methods where hand backfill is not required.
 - d. Until compacted depth over conduit exceeds 3 feet, do not drop fill material over 5 feet. Distance may then be increased 2 feet for each additional foot of cover.

2A - SITE PREPARATION AND EARTHWORK: continued

- e. Insure thorough compaction of fill under and around the conduit for the full length.
 - f. Accomplish without inundation or flooding.
 - g. Backfill failing to meet required densities shall be removed or scarified and recompactd as necessary to achieve specified results.
 - h. All backfill under existing utilities shall be granular pipe embedment, vibratory compacted to 70% relative density.
2. Granular Pipe Embedment:
- a. Granular pipe embedment material shall be as specified for granular fill material.
 - b. Place granular bedding to conform to the following:
 - (1) Level bottom layer at proper grade to receive and uniformly support pipe barrel throughout its length.
 - (2) Form shallow depression under each joint to facilitate grouting.
 - (3) Form depression under each joint such that no part of bell or coupling is in contact with trench when pipe is placed in position.
 - (4) Add second layer simultaneously to both sides of the pipe with care to avoid displacement.
 - (5) Complete promptly after grouting of joint and approval to proceed.
 - (6) Substitute for any part of earth backfill to within 2 feet of final grade at Contractor's option.
 - c. Compact granular bedding as follows:
 - (1) In lifts not exceeding 12 inches in compacted depth.
 - (2) Rod, spade, or use pneumatic or vibratory equipment as follows:
 - (a) As required to obtain not less than 70 percent relative density as determined by ASTM Method D2049, STP 479, or USBR E-12.
 - (b) Throughout depth of embedment.
 - d. Include arch or total concrete encasement as follows:
 - (1) In locations indicated or where approved by Engineer to correct overwidth trench condition.
 - (2) Form to dimensions indicated or construct full width of trench.
 - (3) Place 4000 psi concrete, plain or reinforced, conforming to DIVISION 3, as required.
 - (4) Start and terminate encasement at a pipe joint.
 - (5) Install keyed construction joints coincident with pipe joints at 30- to 36-foot intervals. Provide separation of at least 75 percent of cross-section area at construction joints. Do not run horizontal steel through joint.
 - (6) Suitably support and block pipe to maintain position and prevent flotation.
 - (7) Place promptly after installation of granular bedding.
 - (8) Protect against damage by heavy equipment with layer of earth.
 - e. Include concrete cradle as follows:
 - (1) In locations indicated and where designated by Engineer to reinforce unstable trench bottom.
 - (2) Place on undisturbed trench bottom or on stabilized subbase.
 - (3) Form to dimensions shown or construct full width of trench.
 - (4) Place 4000 psi concrete, plain or reinforced, conforming to DIVISION 3, as required.
 - (5) Start and terminate cradle at a pipe joint.
 - (6) Place without horizontal construction joints other than indicated.

2A - SITE PREPARATION AND EARTHWORK: continued

- (7) Suitably support and block pipe to maintain position and prevent flotation.
- (8) Provide anchorage where indicated.
- 3. Earth Pipe Embedment:
 - a. Earth pipe embedment shall be as indicated and shall be used at impervious trench checks.
 - b. Shape trench bottom to fit the pipe and backfill throughout depth of trench with compacted impervious materials.
- 4. Structures:
 - a. Backfill only after concrete has attained 70 percent design strength.
 - b. Backfill adjacent to structures only after, in the opinion of Engineer, a sufficient portion of the structure has been built to resist the imposed load.
 - c. Remove all debris from excavation prior to placement of material.
 - d. Use material free of gravel, rock, or shale particles larger than 2 inches within one foot of structure.
 - e. Perform backfilling simultaneously on all sides of structures.
 - f. Place backfill in level layers within compacting ability of equipment used.
 - g. Exercise extreme care in the use of heavy equipment in areas adjacent to structures.
 - h. Accomplish compaction without inundation or flooding.
 - i. Compact to 70 percent of relative density at optimum moisture.

L. EMBANKMENT:

- 1. Placement:
 - a. Place embankment to the contours and elevations indicated, using suitable approved material from excavations or borrow areas.
 - b. Place fill material in 12-inch maximum layers (uncompacted depth) in areas requiring 70 percent relative density. Fill material shall be placed uniformly on the entire length of the embankment.
 - c. Place embankment only on ground surfaces which have been compacted by rolling, roughened by discing or scarifying to 6 inches deep, wetted or dried as required to obtain correct moisture content, and approved by Engineer.
 - d. Do not place snow, ice or frozen earth in fill and do not place fill on a frozen surface.
- 2. Compaction: Obtain compaction by normal methods and equipment during the placing and grading of layers or to the minimum density specified for particular locations.

M. SUBGRADE PREPARATION:

- 1. General:
 - a. Excavate or backfill as required to construct subgrades to the elevations and grades indicated.
 - b. Remove all unsuitable material and replace with approved fill material, and perform all wetting, drying, shaping, and compacting required to prepare a suitable subgrade.
- 2. Subgrade for Fills and Embankments: Roughen by discing or scarifying and wet or dry top 6 inches as required to insure bond with fill or embankment.

2A - SITE PREPARATION AND EARTHWORK: continued

3. Subgrade for Roadways, Railroads, Drives, Parking Areas:
 - a. Extend subgrade the full width of the surfaced area plus one foot outside the edges of the overlying course to be placed.
 - b. Compact subgrade embankments to 70 percent relative density.
4. Subgrades for Concrete Slabs on Grade:
 - a. Compact subgrade in embankment excavation areas to 70 percent relative density.
 - b. Place granular fill material on compacted subgrade in areas and to thickness as indicated. Compact by rolling and tamping until firm.

N. TOPSOILING:

1. Place topsoil on all areas indicated and on approved waste areas.
2. Subgrade Treatment:
 - a. Clear site of vegetation heavy enough to interfere with proper grading and tillage operations.
 - b. Clear surfaces of all stones or other objects larger than 3 inches in thickness or diameter, all roots, brush, wire, grade stakes, or other objectionable material.
 - c. Loosen subgrade by discing or scarifying to a depth of 2 inches wherever compacted by traffic or other causes to permit bonding of the topsoil to the subgrade.
3. Placement:
 - a. Distribute over required areas without compaction other than that obtained with spreading equipment.
 - b. Place to extent material is available within following limits:
 - (1) Not less than 4 inches in depth.
 - (2) Do not exceed 6 inches in depth.
 - c. Shape cuts, fills and embankments to contours shown.
 - d. Grade to match contours of adjacent areas and permit good natural drainage.
 - e. With gentle mound over trenches.
4. After topsoil has been spread, clear surface of stones or other objects larger than 2 inches in thickness or diameter and all other objects that might interfere with planting and maintenance operations.
5. Protect topsoiled areas from the elements until grass is established. Repair eroded areas as required.
6. Keep paved areas clean. Promptly remove topsoil or other dirt dropped on surfacing.

O. FILTER BLANKET:

1. Foundation Preparation:
 - a. Areas on which filter blankets are to be placed shall be uniformly trimmed and dressed to conform to cross sections indicated within an allowable tolerance of plus or minus 1 inch from the theoretical slope lines and grades.
 - b. Where such areas are below the allowable minus tolerance limit they shall be brought to grade by filling with filter blanket material.
 - c. Slopes shall be approved by Engineer prior to placing filter blanket materials.
2. Placement of Filter Blanket Materials:
 - a. Place on the slopes within the limits as indicated.

2A - SITE PREPARATION AND EARTHWORK: continued

- b. Material shall be spread uniformly on the prepared base, in a neat and satisfactory manner to a thickness of six (6) inches.
- c. Placing or spreading of material by methods which will tend to segregate particle sizes within the filter will not be permitted.
- d. Any damage to the surfaces of the filter blanket foundation during the placing of the filter blanket material shall be repaired before proceeding with the Work.
- e. Compaction of the filter blanket material will not be required, but it shall be finished to present a reasonably even surface free from mounds, depressions or windrows.

P. RIPRAP:

1. Foundation Preparation:

- a. Trim and dress areas requiring riprap to conform to cross sections indicated within an allowable tolerance of plus or minus 2 inches from the theoretical slope lines and grades.
- b. Where such areas are below the allowable minus tolerance limit, they shall be brought to grade by filling with riprap.

2. Placement of Riprap:

- a. Place on the slopes within the limits as indicated.
- b. Place riprap on the prepared base in such a manner as to produce a reasonably well graded mass of rock with a minimum practicable percentage of voids.
- c. Place to its full course thickness in one operation in a manner to avoid displacing the base material.
- d. Finished riprap shall be free from objectionable pockets of small stones and clusters of larger stones. Hand place only if necessary to secure the desired results.
- e. A tolerance of plus or minus 4 inches from the slope lines and grades will be allowed to the extremes that such a tolerance shall not be continuous over an area greater than 200 square feet.
- f. Maintain the riprap protection until accepted and replace any material displaced by any cause.
- g. Filter point style mats of Fabriform as manufactured by Construction Techniques, Inc., or approved equal is considered an acceptable alternate to riprap provided it is installed in accordance with manufacturer's recommendations. Mat thickness shall be subject to the approval of the Engineer.

Q. WEED KILLER:

- 1. Shall be placed in the areas indicated and specified.
- 2. Shall be used in accordance with manufacturers recommendations.

R. MAINTENANCE AND REPAIR:

1. Maintenance:

- a. Protect newly graded and topsoiled areas from actions of the elements.
- b. Settling or erosion occurring prior to landscaping shall be filled and repaired and grades reestablished to the required elevations and slopes.

2. Correction of Settlement:

2A - SITE PREPARATION AND EARTHWORK: continued

- a. Under provisions of the guarantee, Contractor is responsible for correcting any settlement in excess of the amount of the specified grading tolerance for the specific areas of embankments or backfill and damages created thereby within one year after acceptance of the Work.
- b. Make repairs within 10 days from and after due notification by Owner of embankment or backfill settlement and resulting damage.
- c. Make own arrangements for access to the site for purposes of repair.

S. CLAY LINER:

1. Placement:
 - a. Place clay liner to contours and elevations indicated, using stockpiled silty clay or other suitable cohesive liner material from excavations or borrow areas as approved by Engineer.
 - b. Place material in 8-inch maximum layers (uncompacted depth) in all areas requiring clay liner.
 - c. Place material only on ground surfaces which have been compacted by rolling, roughened by discing or scarifying to 6 inches deep, wetted or dried as required to obtain correct moisture content, and approved by Engineer.
 - e. Placement of clay liner on or near concrete storm sewer through Bottom Ash - Scrubber Sludge Pond is to be accomplished with equipment whose gross axle weight is not to exceed 60,100 pounds.
 - f. Do not place snow, ice or frozen earth in clay liner or on frozen surface.
2. Compaction: Obtain compaction by normal methods and equipment during the placing and grading of layers or to the minimum density specified for particular locations.
3. Liner Protection:
 - a. Protect Liner against hydrostatic uplift pressures during construction and until all ponds have been filled to a minimum depth of 6 feet of water. Contractor shall not use potable water supplied by the City of Sikeston for the purpose of filling the ponds.
 - b. During filling of the ponds take adequate measures to prevent erosion of Liner material.
 - c. Contractor shall submit as part of the dewatering plan as specified in Section 2A-3.F.7, a plan for the protection of the installed clay liner against hydrostatic uplift pressure.

* * * * *

2B - STORM DRAINAGE SYSTEM:

2B-1 GENERAL

A. DESCRIPTION:

1. This Section includes storm drainage pipe and appurtenances, manholes, and inlet and outlet structures.
2. Related Work Specified Elsewhere:
 - a. Site Preparation and Earthwork: SECTION 2A.
 - b. Concrete: DIVISION 3.

B. QUALITY ASSURANCE:

1. Applicable Standards:
 - a. American Society for Testing and Materials (ASTM):
 - (1) A48 - Gray Iron Castings.
 - (2) C14 - Concrete Sewer, Storm Drain and Culvert Pipe.
 - (3) C76 - Reinforced Concrete Culvert, Storm Drain and Sewer Pipe.
 - (4) C443 - Joints for Circular Concrete Sewer and Culvert Pipe, Using Flexible, Watertight, Rubber Gaskets.
 - (5) C478 - Precast Reinforced Concrete Manhole Sections
 - (6) C506 - Reinforced Concrete Arch Culvert, Storm Drain, and Sewer Pipe.
 - b. American Association of State Highway and Transportation Officials (AASHTO):
 - (1) M36 - Zinc Coated (Galvanized) Corrugated Iron or Steel Culverts and Underdrains.
 - (2) M190 - Bituminous Coated Corrugated Metal Culvert Pipe and Arches.
 - c. American Water Works Association (AWWA):
 - (1) M9 - Installation of Concrete Pipe.
2. Acceptable Manufacturers: Specified in PART 2G-2.

C. COMPLIANCE SUBMITTALS:

1. Submit as specified in DIVISION 1.
2. Includes, but not limited to, the following:
 - a. Layout drawings.
 - b. Specifications.
 - c. Complete details of pipe fittings and specials.
 - d. Bill of material.

2B-2 MATERIALS

A. REINFORCED CONCRETE:

1. Conform to applicable requirements of DIVISION 3.
2. Concrete shall be 4,000-psi concrete.

B. IRON CASTINGS: Conform to ASTM A48, of the type and size specified and as indicated.

1. Inlet frames and grates shall be as follows:
 - a. No. R-4896-5 Type A for Type I drop inlets as manufactured by Neenah Foundry Company.
 - b. No. 1001233 for Type II drop inlets as manufactured by Armco Steel Corporation.
 - c. No. R-6670-B2 Type Y for drop inlets.

2B - STORM DRAINAGE SYSTEM: continued

C. CORRUGATED METAL PIPE (CMP):

1. Pipe shall conform to AASHTO M190 and shall be of full circle lock seam or welded type. Coating shall be as follows:
 - a. Coal runoff pipe (SS-16, A, B, C, and D), bottom ash and scrubber sludge pond overflow pipe, fly ash overflow pipes #1 and #2 coating shall be Type D.
 - b. All other storm sewer pipes shall be Type A unless otherwise specified.
2. End sections shall be galvanized metal with toe plates.
3. Pipe shall be of size, length and gauge thickness as indicated.
4. Coupling bands for all CMP's shall conform to AASHTO M190 except as follows:
 - a. Coupling bands for CMP's with Type D coating shall be hugger type which mesh with the corrugations of the adjacent ends and which are supplemented by o-ring type neoprene gaskets.

D. REINFORCED CONCRETE PIPE:

1. Design of circular pipe to conform to ASTM C76 except as modified herein.
2. Furnish in lengths of not less than 8 feet, except fittings, closure pieces and specials.
3. Joints shall be rubber and concrete to conform to ASTM C443. Rubber gaskets shall be of O-ring cross section.
4. Select an independent testing laboratory to perform testing and inspection of all material except reinforcing steel. Laboratory shall be acceptable to Owner.

2B-3 PERFORMANCE

- A. TRENCHING AND BACKFILLING: Perform trenching and backfilling of trenches as specified in SECTION 2A.
- B. EXCAVATION, FILLING, AND BACKFILLING FOR STORM DRAINAGE STRUCTURES: Perform as specified in SECTION 2A.
- C. PIPE INSTALLATION: All pipe shall be carefully laid true to lines and grades indicated. Any pipe which is not in true alignment or which shows undue settlement after laying shall be taken up and relaid at the contractor's expense.
 1. Corrugated metal pipe:
 - a. Install to conform to manufacturer's recommendations.
 - b. Lift or roll pipe to protect bituminous coating. Do not drag over gravel or rock. Avoid striking rocks or hard objects when lowering into trench.
 - (1) Pipe on which bituminous coatings have been damaged may be rejected at the site of the work regardless of previous approvals.
 - c. Join pipe sections with firmly bolted coupling bands of the same material as the pipe.
 2. Reinforced Concrete Pipe:
 - a. Install to conform to AWWA M9 and as follows:
 - b. Perform jointing to conform to pipe manufacturer's recommendations.
 - c. Clean joints thoroughly, and coat bell and spigot and gasket with recommended lubricant before jointing.

2B - STORM DRAINAGE SYSTEM: continued

- d. Check position of rubber gasket with feeler prior to shoving pipe home.
- e. Fill exterior pipe with a 1:2 cement mortar of pouring consistency and cover with a waterproof paper or cloth diaper wired in position. Rod mortar with a stiff wire curved to the radius of the pipe.
- f. Fill interior of joint with stiff mix of 1:1 cement mortar troweled into place to provide a continuous smooth surface across joint (pipe 24 inches in diameter and larger).

D. STORM DRAINAGE STRUCTURES:

1. Reinforced Portland Cement Concrete: All reinforced portland cement concrete storm drainage structures shall have a paved invert and a smooth grade from pipe invert to pipe invert in structures having more than one pipe.
 - a. Cast-in-place: Conform to all applicable requirements of DIVISION 3.
 - b. Precast: Structures shall be of precast construction where indicated or as approved by Engineer. Precast structures shall have cast-in-place reinforced concrete base conforming to DIVISION 3.
 - (1) Precast manholes: Conform to ASTM C478. Joints shall be of rubber and concrete conforming to ASTM C443, paragraph 18. Rubber gaskets shall be of the O-ring type.

E. DRAINAGE PIPE ABANDONMENT (CMP):

1. Remove exposed sections of pipe (along with end sections, if present).
2. Fill pipe with concrete as to allow no large air voids to exist inside the CMP.
3. Cover both ends and allow concrete to cure.

* * * * *

2C - SEEDING

2C-1 GENERAL

A. DESCRIPTION:

1. This Section includes seedbed preparation, seeding, mulching, netting and fertilizing of areas within topsoil limits.

B. QUALITY ASSURANCE:

1. Applicable Standards:
 - a. American Association of State Highway and Transportation Officials (AASHTO).
 - (1) M140 - Emulsified Asphalt.

C. SUBMITTALS:

1. Certificates:
 - a. Seed shall be accompanied by certificate from vendor that seed meets requirements of these specifications.
 - b. Fertilizer shall be accompanied by certificate from vendor that fertilizer meets requirements of these specifications.

2C-2 MATERIALS

A. SEED:

1. Seed shall conform to all applicable laws of the State of Missouri.
2. Seed shall be labeled according to the U.S. Department of Agriculture Federal Seed Act and shall be furnished in containers with tags showing seed mixture, purity, germination, weed content, name of seller, and date on which seed was tested.
 - a. Seed shall meet the following minimum percentage requirements for purity and germination:

<u>Seed Name</u>	<u>Purity</u>	<u>Germination</u>
Alta Fescue	95	85
Perennial Rye Grass	98	90
Redtop	90	80

- b. Moldy seed or seed that has been damaged in storage shall not be used.

B. FERTILIZER:

1. Fertilizer shall be an inorganic 10-20-0 commercial grade.
 - a. Uniform in composition.
 - b. Free flowing and suitable for application with approved equipment.
2. Deliver to site in labeled bags or containers.

C. MULCH: (May be any of the following at Contractor's option)

1. Vegetative Mulch: Mulch shall be straw with stalks of wheat, rye, oats, or hay from fields of timothy, redtop, bromegrass, or other approved materials, and shall be partially decomposed.
2. Asphalt Emulsion: Conform to AASHTO M140, type SS-1.
3. Wood Cellulose Fiber:
 - a. Mulch shall not contain germination or growth inhibiting ingredients.
 - b. Mulch shall be dyed an appropriate color to aid in visual inspection.
 - c. Mulch material shall be easily and evenly dispersed when agitated in water.

2C - SEEDING: continued

- d. Supply in packages of not more than 100 pounds gross weight, and be marked by the manufacturer to show the air dry weight content.
- D. EROSION CONTROL NETTING: May be any of the following at Contractor's option.
1. Plastic Netting:
 - a. The netting shall be an extruded rectangular mesh plastic:
 - Color: Black or green.
 - Weight: 2.6 lbs/1000 sq ft ($\pm\frac{1}{2}$ lb).
 - Width: 7 $\frac{1}{2}$ ', 12', 15' (-0+4%).
 - Length: 2500 ft.
 - Mesh Opening: 3/4" x 1" approximately.
 - b. The netting shall be rolled on a 3-inch outside diameter cardboard core and paper wrapped in trailer loads or less.
 - c. The netting shall be as manufactured by Conweb Corporation or approved equal.
 - d. The staples shall be of No. 11 gauge, or heavier, steel wire, "U" shaped square topped and not less than 6 inches long.
 2. Jute Netting:
 - a. Jute netting shall consist of a uniform, open, plain weave mesh of smolder-resistant, unbleached single jute yarn.
 - (1) Yarn shall be of loosely twisted construction and shall not vary in thickness by more than one-half its normal diameter.
 - (2) Jute mesh shall be furnished in rolled strips and shall be as follows:
 - (a) Minimum width of 42 inches.
 - (b) 5.5 wrap yarns by 3.5 filling yarns per inch.
 - (3) Staples shall be of No. 11 gauge, or heavier, steel wire, "U" shaped and not less than 6 inches in length.

2C-3 PERFORMANCE

- A. SEEDBED:
1. Dispose of any growth, rocks, or other obstructions which might interfere with tilling, seeding, sodding, or later maintenance operations.
 2. Thoroughly loosen and pulverize topsoil to a depth of at least three inches.
 3. Maintain tilled areas until seeded and mulched, or sodded to provide a smooth area with no gullies or depressions.
- B. FERTILIZING:
1. Apply fertilizer at the rate of 300 pounds per acre to properly prepared seedbeds and sodbeds.
 2. Incorporate fertilizer into the soil to a depth of at least 2 inches by discing, harrowing or raking, except where applied hydraulically on slopes steeper than 2 horizontal to 1 vertical.

2C - SEEDING: continued

C. SEEDING:

1. Seed mixture and rate of application shall be as follows:

<u>Seed Name</u>	<u>Pounds Per Acre</u>
Alta Fescue	90
Perennial Rye or Redtop	<u>10</u>
Total	100

2. Seasonal Limitations: Perform seeding only during the following seasons:

- a. March 15 to May 15.
- b. August 10 to September 30.

3. Methods of Application:

- a. Dry Seeding: Accomplish sowing by use of approved equipment, having drills no more than 4 inches apart.
 - (1) Drill seed to an average depth of one-half inch.
 - (2) Overlap successive seed strips to provide uniform coverage. Repeat where skipped areas appear after a show of green.
- b. Hydraulic Seeding: Mix seed with water and constantly agitate. Do not add seed to water more than 4 hours before application.
 - (1) On slopes of 2 horizontal to 1 vertical or flatter, apply seed separately from fertilizer. Cover seed with soil to an average depth of one-half inch by raking or other approved methods.
 - (2) On slopes steeper than 2 horizontal to 1 vertical, seed and fertilizer may be applied in a single operation. Incorporation into the soil will not be required.

D. MULCHING:

1. Apply a mulch covering to all seeded areas.
2. Apply vegetative mulch at the rate of 2½ tons per acre by means of a mechanical spreader or other approved methods with asphalt emulsion.
3. Apply asphalt emulsion mulch at the rate of 250 gallons per acre when applying vegetative mulch.
 - a. Firm and adequately moisten the seedbed prior to application of the mulch.
 - b. Temperature of mulch at time of application shall be between 125 and 175 degrees F.
 - c. Hand spray near structures.
 - d. Do not use in areas where netting is indicated.
4. Apply wood cellulose fiber mulch hydraulically at the rate of 1000 gallons per acre.
 - a. Mulch and seed may be applied in a single operation.
 - b. Apply mulch to achieve a uniform coverage of the soil surface.
5. Immediately following the application of the mulch, water the seeded area in one watering, in sufficient amount to penetrate the seedbed to a minimum depth of 2 inches. Perform so as not to cause erosion or damage to the seeded surface.

2C - SEEDING: continued

E. NETTING:

1. Install netting where indicated. Install netting immediately following mulching operations.
2. Roll netting loosely over the required areas. Lifting and stretching of the material will not be permitted.
3. Secure netting by staples spaced every 1 - 2 feet apart along top and bottoms and no more than 4 feet apart, along sides and across remaining unanchored netting forming an "X" pattern.
4. Lap joints in the direction of water flow.
5. After the netting is secured in place by staples, press firmly against the surface of the soil by tamping or by rolling with an approved smooth-wheel hand roller (for Jute netting only).
6. Any seeded or mulched areas disturbed by the installation of the netting shall be repaired at the Contractor's expense.

F. MAINTENANCE:

1. Mow grass to a height of 2 inches whenever average height of grass exceeds 5 inches.
2. Remove weeds by pulling or chemical treatment.
3. Erect and maintain signs or barricades to exclude traffic from seeded areas.
4. Seeded Areas: Perform maintenance until the acceptance of the completed contract.
 - a. Water seeded areas as required by good practice, and as necessary to obtain a flourishing cover.
 - b. Any portion of the seeded surface which becomes gullied or otherwise damaged, or the seeding becomes damaged or destroyed, shall be repaired at the Contractor's expense.

G. MEASUREMENT AND PAYMENT:

1. Time of Completion: Completion time for seeding and sodding shall not apply to provisions for liquidated damages with respect to contract completion time. Payment for seeding will be withheld until such work is accepted.

* * * * *

2D - TEMPORARY FENCE (Woven and Barbed Wire):

2D-1 GENERAL

A. DESCRIPTION:

1. This Section covers woven-wire and barbed wire fencing with steel posts.
2. Related Work Specified Elsewhere:
 - a. Concrete: DIVISION 3.

B. QUALITY ASSURANCE:

1. Applicable Standards:
 - a. American Society for Testing and Materials (ASTM):
 - (1) A153 - Zinc Coating (Hot-Dip) on Iron and Steel Hardware.
 - b. American Steel Wire Gauge (ASWG).
 - c. Federal Specifications (FS):
 - (1) RR-F-183 - Fence Posts, Gates, and Accessories.
 - (2) RR-F-191 - Fencing, Wire and Post, Metal.
 - (3) RR-F-221 - Fencing, Wire (Barbed-Wire, Woven Wire and Wire Netting), Fence Posts and Accessories:

C. COMPLIANCE SUBMITTALS:

1. Submit as specified in DIVISION 1.
2. Include the following:
 - a. Certification that woven-wire and barbed-wire fencing materials meet Specifications.
 - b. Fabrication and erection drawings on gate(s) and accessories.

2D-2 MATERIALS

A. GENERAL:

1. Materials of manufacturers' standard products where such products conform to Specifications.

B. STEEL LINE POSTS:

1. 1-3/8 inches by 1-3/8 inches by 7/64-inch tee posts with anchor plates.
2. Minimum length of 8 feet.
3. Aluminum or baked-enamel finish.

C. WIRE FABRIC:

1. Conform to FS RR-F-221, Type II, Woven-Wire, Style 4, No. 11 Farm Fence.
2. 47-inch height with 10 horizontal wires, and stays 6 inches on center.
3. Top and bottom horizontal wires: No. 9 gauge.
4. Intermediate and stay wires: No. 11 gauge.
5. Zinc-coated, Class 1.

D. BARBED WIRE:

1. Conform to FS RR-F-221, Type I, 2-point pattern, round barbs spaced 4 inches oc.
2. Strand Size: No. 12½ gauge.
3. Barb Size: No. 14 gauge.
4. Zinc-coated, Class 1.

2D - TEMPORARY FENCE (Woven and Barbed Wire): continued

E. GATES AND ACCESSORIES:

1. Conform to RR-F-183, swing type.
2. Gate Size: 60 inches height (including end-member extensions) x width indicated.
3. Gate Frame:
 - a. 1½-inch od tubular steel, zinc-coated.
 - b. Two intermediate center braces and diagonal truss rods as required to provide ample strength and free from sag and twist.
 - c. End members with frame extended above top members and furnished with clips for attachment of barbed wire.
 - d. Joints welded and zinc-coated, or watertight rigid connections.
4. Gate Fabric:
 - a. Conform to RR-F-191, Type A, chain link zinc-coated, Class 1, 2-inch mesh.
 - b. Barbed-wire top as indicated.
5. Latches and Keepers:
 - a. Forked-latch type arranged for padlocking.
 - b. Keeper designed for securing and supporting free end of gate in full-open position.
6. Hinges:
 - a. Heavy pattern, malleable, and of adequate strength for gate size, zinc-coated.
 - b. Welded to gate frame.
 - c. Arranged so gate may be swung back parallel with the fence.

F. CONCRETE: As specified in DIVISION 3.

2D-3 PERFORMANCE

A. INSTALLATION:

1. Posts:
 - a. Set corner and gate posts in concrete as indicated.
 - b. Brace corner and gate posts as indicated.
2. Fencing:
 - a. Attach woven-wire fence to outside of posts with not less than 5 galvanized ties per steel line post.
 - b. Mount two strands of barbed wire above the woven-wire fencing; bottom strand 6 inches above top of woven wire and top strand 6 inches above bottom strand.
 - c. Attach barbed wire to the outside of posts with galvanized ties to steel line posts.
 - d. Install gates with required hardware. Arrange keepers to support and secure free end of gate in full-open position.

* * * * *

2E - FENCES AND GATES -SECURITY TYPE

2E-1 GENERAL

A. DESCRIPTION:

1. This Section covers chain-link fabric fence, gates and motor operator.
2. Related Work Specified Elsewhere:
 - a. Concrete: DIVISION 3.
 - b. Site Preparation: DIVISION 2.

B. QUALITY ASSURANCE:

1. Applicable Standards:
 - a. Federal Specifications (FS):
 - (1) FF-B-575 - Bolts, Hexagon and Square.
 - (2) RR-F-191 - Fencing, Wire and Post, Metal (Chain-Link Fence Fabric, Chain-Link Fence Gates, Chain-Link Fence Posts, Top Rails and Braces and Chain-Link Fence Accessories).
 - (3) RR-F-221 - Fencing, Wire (Barbed Wire, Woven Wire and Netting, Fence Post and Accessories).
 - b. Acceptable Manufacturers:
 - a. Fences and Gates:
 - (1) Structo Corporation.
 - (2) Anchor Fence Division, Anchor Post Products Inc.
 - (3) Broski Bros. Inc.
 - (4) U.S. Steel Supply Division, U.S. Steel Corp.
 - b. Motor Operated Gate:
 - (1) Richards Wilcox Division of Hupp Corporation.
 - (2) Robot Industries, Inc.
 - (3) Vemco Products, Inc.
 - (4) Rusco, Inc.

C. SUBMITTALS:

1. Compliance Submittals:
 - a. Submit as specified in DIVISION 1.
 - b. Includes, but not limited to, the following:
 - (1) Plan layout.
 - (2) Details illustrating fence height, sizes of posts, rails, braces, gates, and hardware list.
 - (3) Erection procedures.

2E-2 EQUIPMENT AND MATERIALS

A. GENERAL:

1. Manufacturer's standard materials where such materials conform to these Specifications.
2. Conform to FS RR-F-191 except as indicated or specified otherwise.
3. Fence Height: 7'-0". Gate width as indicated.
4. Finish for framework and appurtenances: Galvanized with minimum weight for zinc per square foot as follows:
 - a. Pipe: 1.8 ounces.
 - b. Square Tubing: 2.0 ounces.
 - c. H-Sections: 2.0 ounces.
 - d. Hardware and accessories: Conform to FS RR-F-191.

2E - FENCES AND GATES - SECURITY TYPE: continued

- e. Fabric 2.0 ounces heavy weight.
- f. Barbed Wire: 0.80-ounce.

5. All materials furnished shall comply with the above requirements.

B. FABRIC:

- 1. No. 9-gauge, 2-inch diamond mesh chain-link fabric.
- 2. Top and bottom selvage twisted and barbed.
- 3. Fabric fastenings of 9-gauge galvanized wire ties.

C. POSTS, TOP RAIL AND BRACES: Minimum size and weight as follows:

- 1. Posts:
 - a. End, Angle, Corner or Pull Posts: 2.875 inches od at 5.79 pounds per foot.
 - b. Line Posts: 2.375 inches od at 3.65 pounds per foot or 2.25 inches x 1.95 inches x .143-inch H-Section at 4.10 pounds per foot.
 - c. Gate Posts: 4.0 inches od at 9.10 pounds per foot.
- 2. Top Rail:
 - a. 1.660 inch od at 2.27 pounds per foot or roll formed section at 192 pounds bending strength.
 - b. 18-foot minimum length of each section.
 - c. Expansion type couplings for each joints.
- 3. Post Bracing:
 - a. Diagonal truss rods 3/8-inch in diameter equipped with truss tightener.
 - b. Horizontal Braces: 1.660-inch od at 2.27 pounds per foot or H-Section at 2.27 pounds per foot.
- 4. Post Tops:
 - a. Designed as a weathertight closure cap for tubular posts.
 - b. Malleable iron or pressed steel.
- 5. Barbed Wire Supporting Arms:
 - a. Single arm at 45 degrees with vertical, sloping to outside of fence.
 - b. Constructed for attaching three rows of barbed wire to each arm and designed as a weathertight closures cap for tubular posts.
 - c. Designed for 300-pound minimum pull down load.
 - d. Attached to steel posts or integral with post top.
 - e. Provided with openings to receive top rail.
 - f. Malleable iron or pressed steel.
- 6. Stretcher Bars:
 - a. One piece, full height of fabric.
 - b. 3/16-inch x 3/4-inch, galvanized.
 - c. Bands of galvanized steel or malleable iron.
- 7. Bolts:
 - a. Zinc coated.
 - b. Conform to FS FF-B-575.

D. BARBED WIRE:

- 1. Two-strand, 12½-gauge wire with 4-point barbs 5 inches oc.
- 2. Conform to FS RR-F-221, Type I, Style 2.
- 3. Three rows required.

2E - FENCES AND GATES - SECURITY TYPE: continued

E. GATES: Manual-Swing

1. Framing:

- a. Frames of tubular members, 1.90-inch od at 2.72 pounds per foot.
- b. Intermediate horizontal and vertical members for proper gate operation and for attachment of fabric, hardware and accessories.
- c. Frames assembled by welding or watertight galvanized steel rigid fittings.
- d. Diagonal cross bracing of 3/8-inch diameter adjustable truss rods to provide frame rigidity.
- e. Gate end members extended one foot above top members to receive 3 rows of barbed wire.

2. Hardware:

- a. Hinges of pressed or forged steel, or malleable iron, non-lift-off type, 2 pair per leaf.
- b. Latches and Gate Stops: Double leaf
 - (1) Plunger-bar type latch, full gate height, designed to engage gate stop of flush-plate type with anchors.
 - (2) Locking device and padlock eyes an integral part of latch.
 - (3) Keeper to automatically engage gate leaf and secure free end of gate in full (90 degrees) open position.
- c. Latches: Single leaf
 - (1) Forked type to permit operation from either side of gate.
 - (2) Padlock eye as integral part of latch.

F. GATES: Motor-Operated

1. General:

- a. Framing: Same as specified for "GATES: Manual-Swing," this Section.
- b. Two (2) sliding gate, 24-foot width per leaf.
- c. One (1) double-swing gate, 12-foot width per leaf.

2. Operator:

- a. One electric motor operator gate mechanism for operating one or each leaf of gate.
- b. Suitable for outdoor use with all parts suitably protected against corrosion.
- c. Necessary limit and indicating light switches, linkages and appurtenances to provide a complete operation. Air circuit breaker type reversing motor starter with 120-volt control transformer capable of supplying local and remote control stations. All mounted in a NEMA Type 4 enclosure.
- d. Flexible hinged connections to conduit if required.
- e. Gate Opener:
 - (1) Capable of fully opening or closing the gate in approximately five seconds or less or 75 feet per minute for sliding gate.
 - (2) Designed for operation on 460-volt, 3-phase, 3-wire ungrounded.
- f. Automatic Locking Device:
 - (1) Designed so that the last few inches of gate travel causes a latch to engage a latch plate mounted in roadway at gate's center.
 - (2) Designed to prevent opening of gate from the outside without card.
- g. Disengaging device to permit manual operation in case of power failure.

2E - FENCES AND GATES - SECURITY TYPE: continued

- h. Richard-Wilcox No. 1510 operator with heavy-duty gear unit and No. 1510 locking device for double-swing gate.
 - i. Richard Wilcox No. 1295 operator with 1-hp drive motor for sliding gate.
3. Conduit and Cable:
- a. Interconnecting wiring between controls and gate operator using 90° C rated, type THHN, insulated copper cable installed in a rigid steel conduit system.
 - b. Provide power to operators from the construction power center. Cable shall be 75° C rated, type THWN, direct buried approximately 30 inches. Final 60 feet to gate operator shall be installed in a buried rigid steel conduit system.
 - c. All conduit in contact with the earth or concrete to be PVC coated.
4. Control Systems:
- a. Unsupervised entrance control at all gates by weatherproof card-key station post-mounted outside of gate on west or north side of road 10 feet from gate. Mounting height to be 4 feet above shoulder. Gate to close after adjustable 15-second to 5-minute delay after card removal. Card reader to be Richard-Wilcox No. 1295-CK.
 - b. Unsupervised exit control at all gates by strip-type driveway pressure switch. Gate to close after adjustable 15-second to 5-minute delay
 - c. Supervised control at one sliding gate by a open-close-stop-pushbutton station located in the guardhouse. Find mounting height and location to be determined later by Engineer's Resident Representative. Close and stop pushbutton to override all unsupervised controls.
 - d. Provide a total of sixteen (16) cards, two (2) coded for each of the possible eight combinations.
 - e. Provide one (1) electrically operated coding and laminating machine complete with all necessary auxiliary equipment and materials, including cardstock and plastic laminate, for the Owner to produce one hundred (100) key cards in any or all of the possible eight combinations.

G. CONCRETE: As specified in DIVISION 3.

H. CRUSHED ROCK: Gradation of 3/4-inch to 1-inch sizes.

2E-3 PERFORMANCE

A. PREPARATION:

- 1. Grading: Perform final grading prior to installation of fence.
- 2. Placing Crushed Rock:
 - a. Place under the fence 6 inches below grade and 2 feet wide centered along post lines.
 - b. Place and spread prior to installing fabric.

B. INSTALLATION:

- 1. Fence:
 - a. Follow general contour of ground and properly align. Install as indicated.
 - b. Posts:
 - (1) Set in concrete bases. Trowel finish tops of footings and dome to direct water away from posts.
 - (2) Install plumb and in straight alignment.
 - (3) Space 10 feet center-to-center maximum.
 - (4) Temporarily brace until concrete in bases has set.

2E - FENCING AND GATES - SECURITY TYPE: continued

- c. Post Bracing:
 - (1) Install at each end post pull and gate post, and each side of each corner post.
 - (2) Install after concrete in post bases has set.
 - (3) Install so posts are plumb when diagonal rod is under tension.
- d. Top Rails:
 - (1) Run continuously through post caps or barbed wire supporting arms.
 - (2) Install expansion couplings at each joint.
- e. Fabric:
 - (1) Stretch taut with equal tension on each side of line posts.
 - (2) Fasten to top rail and steel posts with wire ties.
 - (3) Space wire ties at 12 inches oc maximum on posts and at 24 inches oc maximum on top rail.
- f. Stretcher Bars:
 - (1) Thread through or clamp to fabric 4 inches oc.
 - (2) Secure to posts with metal bands spaced 15 inches oc maximum.
 - (3) Install at each gate, pull and end post, and each side of corner post.
- g. Post Tops and Barbed Wire Supporting Arms: Install on each post.
- h. Barbed Wire:
 - (1) Attach 3 rows to each barbed wire supporting arm. Pull wire taut and fasten securely to each arm.
 - (2) Install 3 rows above fabric and on extended gate end members of swing gates.
- 2. Gates: Manual-Swing
 - a. Install plumb, level, and free swinging through full opening without interference.
 - b. Install all hardware.
 - c. Install keepers, ground set items and flush plate in concrete to engage gate stop.
 - d. Adjust and lubricate as necessary for smooth operation.
- 3. Gates: Motor-Operated
 - a. Include all devices, wiring and appurtenances required for a complete system and satisfactory operation.
 - b. Install to conform to manufacturer's instructions and as indicated.
 - c. Test and adjust system for proper operation.
- 4. Repairing Damaged Coatings:
 - a. Repair any damaged coatings in the shop or field by recoating with compatible and similar coating.
 - b. Apply per manufacturer's recommendations.

* * * * *

2F FOUNDATION PILING

2F-1 GENERAL

- A. DESCRIPTION: This Section includes timber foundation piling.
- B. QUALITY ASSURANCE:
1. Applicable Standards:
 - a. American Society of Testing and Materials (ASTM).
 - (1) D25 - Standard Specification for Round Timber Piles.
 - (2) D390 - Coal-Tar Creosote for the Preservative Treatment of Piles, Poles, and Timbers for Land and Fresh Water Use.
 - (3) D1760 - Pressure Treatment of Timber Products.
 - b. American Wood Preservers Association (AWPA).
 - (1) M4 - Standard for the Care of Pressure Treated Wood Products.
- C. SUBMITTALS:
1. Required Records:
 - a. Include the following for each pile:
 - (1) Name of structure and pile number.
 - (2) Length before driving.
 - (3) Length from point to cutoff after driving.
 - (4) Cutoff elevation.
 - (5) Driving resistance for the last 10 feet of driving.
 - (6) Date of driving.
 - (7) Depth of predrilling performed.
 - (8) Any heaving of redriving data.
 - b. Submit records to the Engineer each day.
- D. HANDLING AND FIELD PROTECTION: Handle piles in accordance with AWPA M4.

2F-2 EQUIPMENT AND MATERIALS

- A. PILES:
1. Round timber piles conforming to ASTM D25 with a minimum butt circumference of 44 inches.
 2. Southern Pine, pressure treated in accordance with ASTM D1760 using coal-tar creosote conforming to ASTM D390.
 3. The minimum allowable compressive stress parallel to the grain shall be not less than 800 psi.
 4. Strapping of the pile at both the butt and the tip will be required if driving causes excessive brooming or damage to the pile. The Engineer will determine if strapping is required. The straps, if required, will have a minimum tensile strength of 5100 pounds and the clips will have a tensile strength of not less than 80 percent of the tensile strength of the strap.
- B. PILE DRIVING EQUIPMENT:
1. Hammer shall be an approved steam or air hammer with a minimum rated driving energy of 15,000 foot pounds per blow and a ram weight of 5000 pounds.
 2. Contractor shall submit details of the hammer and cushion (if used) to the Engineer for approval 14 days prior to the driving of any piles.

2F - FOUNDATION PILING: continued

3. Operate hammer only at speeds and under conditions recommended by hammer manufacturer.
4. Use boiler or compressor with sufficient capacity to operate the hammer continuously at full rated speed and energy.
5. Mount a pressure gauge on the steam or air supply in a position such that it can be clearly read by the pile driver operator.
6. Use fixed leads, secured to the pile driving rig by rigid bracing, and extending to the lowest point hammer must reach to drive piling.
7. Protect piles during driving by a cap and cushion of approved design.
8. Trim and shape pile heads to properly fit cap.

2F-3 PERFORMANCE

A. DRIVING PROCEDURE:

1. Do not drive piles until inspected and approved for driving.
2. Drive each pile continuously and without voluntary interruption until the specified driving resistance has been obtained.
3. Drive piles in a sequence which will minimize heaving of the adjacent piles.

B. PENETRATION AND DRIVING RESISTANCE:

1. Drive piles to elevation 268 (MSL) or to a minimum driving resistance of 20 blows/foot above elevation 268 and below elevation 273.
2. If a driving resistance of twenty (20) blows per foot is encountered with the pile tip above elevation 273 (MSL), the Engineer will determine the acceptability of the pile and may at his option reject the pile and require predrilling for the remainder of the piles to be installed. Discontinue driving immediately on any pile that encounters a driving resistance of twenty (20) blows per foot or greater.

C. JETTING: Jetting will not be permitted without written approval of the Engineer.

D. PREDRILLING:

1. Predrilling will be done only when directed or approved by the Engineer.
2. Where required, perform predrilling in advance of driving to elevation 283.0 (MSL) with a continuous flight helical auger.
3. Do not drill hole larger than the pile.
4. Remove waste from drilling operations from the site.

E. HEAVING:

1. Check heaving on a selected pile within any group or cluster.
2. Check by comparison of elevations of typical pile before and after driving adjacent piles.
3. Heaving shall be considered to have occurred to all piles within a group or cluster when the typical check pile heaves.
4. Redrive all piles within a group or cluster when the typical check pile heaves.
5. Drive to indicated penetration or maximum driving resistance.

2F - FOUNDATION PILING: continued

F. CUTOFF:

1. Cut off piles perpendicular to vertical axis of pile within $\frac{1}{2}$ inch of cutoff elevation indicated.
2. Immediately after making final cutoff, treat the cut area in accordance with AWWA M4.
3. Remove waste pile material from jobsite.
4. Perform cutoff for all piles whether the indicated cutoff elevation is above or below then-existing grade.
5. If excavation is required to achieve pile cutoff, remove excavated material from jobsite.

G. DRIVING TOLERANCE: After driving the pile shall have the following:

1. A variation from vertical or specified batter of not more than $\frac{1}{2}$ inch per foot.
2. A variation from plan location of head at cutoff of not more than 2 inches.

H. SPLICING: Splicing of piles will not be permitted.

I. REQUIRED RECORDS:

1. Include the following for each pile:
 - a. Name of structure.
 - b. Bridge bent number and pile number.
 - c. Cutoff elevation and tip elevation.
 - d. Length of each pile.
 - e. Driving resistance for the last 10 feet of driving.
 - f. Date of driving.
 - g. Depth to which predrilling or jetting was performed.
 - h. Heaving or redriving data.
2. Submit records to the Engineer in triplicate.

J. FIELD MARKING AND ELEVATIONS: Provide an elevation reference point and mark each pile to permit determination of the pile elevation and the driving resistance of each pile for the final 10 feet of driving.

K. REJECTED PILES:

1. The Engineer will determine the acceptability of all piles driven and may, at his option, reject piles which do not conform to the plans and specifications, or which have been damaged during driving.
2. Rejected piles shall be withdrawn and a new pile driven at the indicated location.

2F-4 PAYMENT

- A. The lump sum bid shall be based on an estimated total number of 14 piles having an estimated aggregate bid length of 490 lineal feet in place.
- B. Adjust payment at the unit prices set forth in the proposal for any increase or decrease of the aggregate pay length set forth in A. above due to change in length of individual piles or to change in number of piles.
- C. No payment will be made for rejected piles.

* * * * *

2G - SUBDRAIN

2G-1 GENERAL

A. DESCRIPTION:

1. This section includes preparation activities and materials for construction of subdrains.
2. Related Work Specified Elsewhere:
 - a. Site Preparation and Earthwork: Section 2A.

B. QUALITY ASSURANCE:

1. Applicable Standards:

- a. American Society for Testing and Materials (ASTM):
 - (1) C117 - Test for Materials Finer than No. 200 Sieve in Mineral Aggregate by Washing.
 - (2) C131 - Test for Abrasion of Coarse Aggregates by Use of Los Angeles Machine.
 - (3) C136 - Test for Sieve or Screen Analysis of Fine and Coarse Aggregates.
 - (4) D423 - Test for Liquid Limit of Soils.
 - (5) D424 - Test for Plastic Limit and Plasticity Index of Soils.
 - (6) D2321 - Underground Installation of Flexible Thermoplastic Sewer Pipe.
 - (7) D3034 - Type PSM Poly (vinyl chloride) (PVC) Sewer Pipe and Fittings.
 - (8) 1970, 5th Edition, Special Procedures for Testing Soil and Rock for Engineering Purposes:
 - (a) STP-479 - Burmister Method.
 - (b) D2049 - Relative Density of Cohesionless Soils.
- b. American Association of State Highway and Transportation Officials (AASHTO):
 - (1) T99 - Test for the Moisture Density Relations of Soils Using a 5.5-Pound (2.5 Kg) Rammer and a 12-Inch Drop (305 mm).
- c. U.S. Department of Interior, Bureau of Reclamation, Earth Manual, 1st Edition.
 - (1) E-12 - Relative Density of Cohesionless Soils Part A.
- d. Missouri State Highway Department Standard Specifications for Road and Bridge Construction.
- e. Missouri Standard Specification for Highway Construction.

2. Samples and Testing:

- a. Tests to determine conformance with all requirements for material quality and properties specified herein will be performed by an independent laboratory approved by the Engineer and compensated by the Contractor.
- b. Obtain representative samples of material in accordance with ASTM D75 for testing. Furnish Engineer sufficient material for testing from each sample at the time obtained.
- c. Furnish specific schedule for sampling to provide Engineer the opportunity to observe sampling.
- d. Quality control testing will be performed during construction by a testing laboratory retained by the Owner.

2G - SUBDRAIN: continued

C. COMPLIANCE SUBMITTALS:

1. Submit as specified in DIVISION 1.
2. Includes, but not limited to, the following:
 - a. Layout drawings.
 - b. Specification.
 - c. Complete details of pipe slotting and pipe fittings.
 - d. Bill of material.

2G-2 MATERIALS

A. SLOT-PERFORATED POLYVINYL CHLORIDE (PVC):

1. The pipe shall be slotted with at least two (2) rows of slots, cut perpendicular to the axis of the pipe with the centerlines of the rows separated by one-third the circumference of the pipe. Slots shall have a width of 1/6" and shall have a length, as measured the inside circumference, of 1". Spacing of the slots shall be at 3/4" along the axis of the pipe. Slots shall conform in such a way that inflow of water through the slots will not be impeded by excessive residual material from the slotting procedure. The pipe shall be 6" diameter pipe.

B. SUBDRAIN MATERIAL:

1. Aggregate shall be crushed stone or crushed gravel, free from lumps or balls of clay or other objectionable matter, and reasonably free from thin and elongated pieces of dirt. Aggregates shall consist of angular fragments, durable and sound, and shall be reasonably uniform in density and quality.
2. Percentage of wear shall not exceed 50 after 500 revolutions as determined by ASTM C131.
3. Aggregate shall contain 75 percent by weight of pieces with two or more fractured surfaces if material is crushed gravel.
4. Portion of aggregate passing No. 40 sieve shall be as follows:
 - a. Liquid Limit: Not more than 25 determined by ASTM D423.
 - b. Plastic Index: Not more than 6 determined by ASTM D424.
5. Gradation shall not vary from low limit on one sieve to high limit on adjacent sieve or vice versa. Test by ASTM C136 and C117, and conform to the following (The Contractor may choose either gradation at his option):

<u>Sieve Size</u>	<u>Percent Passing</u>
1½-inch	100
½-inch	55-90
No. 10	20-50
No. 20	15-35
No. 100	0-10
No. 200	0-3

2G-3 PERFORMANCE

- A. TRENCHING AND BACKFILLING: Perform trenching and backfilling of trenches as specified in Section 2A.

2G SUBDRAIN: continued

B. SUBDRAIN MATERIAL PLACEMENT:

1. Subdrain material shall be as specified.
2. Place subdrain material to conform to the following:
 - a. Level bottom layer at proper grade to receive and uniformly support pipe barrel throughout its length.
 - b. Form shallow depression under each joint to facilitate grouting.
 - c. Form depression under each joint such that no part of bell or coupling is in contact with trench when pipe is placed in position.
 - d. Add second layer simultaneously to both sides of the pipe with care to avoid displacement.
 - e. Complete promptly after jointing of pipe and approval to proceed.
 - f. Backfill to limits shown on drawings.
3. Compact subdrain material as follows:
 - a. In lifts not exceeding 12 inches in compacted depth.
 - b. Rod, spade, or use pneumatic or vibratory equipment as follows:
 - (1) As required to obtain not less than 70 percent but not more than 80 percent relative density as determined by ASTM Method D2049, STP 479, or USBR E-12.
 - (2) Throughout depth of embedment.

- C. PIPE INSTALLATION: Conform to ASTM D2321 for thermoplastic sewer pipe, manufacturer's recommendations for PVC, and as specified in Section 17D.

* * * * *

DIVISION 3 - CONCRETE

3A - FORMS

3A-1 GENERAL

A. DESCRIPTION:

1. This Section includes formwork for concrete.
2. Related Work Specified Elsewhere:
 - a. Concrete: SECTION 3C.
 - b. Steel Reinforcement: SECTION 3B.

B. QUALITY ASSURANCE:

1. Applicable Standards:
 - a. American Concrete Institute (ACI):
 - (1) ACI 318 - Building Code Requirements for Reinforced Concrete.
 - (2) ACI 347 - Recommended Practice for Concrete Formwork.

3A-2 EQUIPMENT AND MATERIALS

A. MATERIALS FOR FACING:

1. Where concrete will be exposed to view after construction:
 - a. Smooth finish exterior grade plywood at least 5/8-inch thick.
 - b. Steel.
2. Where concrete will not be exposed to view after construction:
 - a. Exterior grade plywood at least 5/8-inch thick.
 - b. Steel.
 - c. Wood fiberboard.
 - d. Dressed lumber free of loose knots.
3. Treat forms to prevent bonding to concrete with lacquer, form oil or other acceptable material. Material shall not stain or cause injury to exposed concrete surfaces or affect them in any manner to prevent bond of specified surface application.
4. Clean forms of sawdust, dust, dirt, and other foreign materials.

B. FORM TIES:

1. Break-back, coil, or screw-type, except where otherwise specified.
2. Water seal coil type in walls below grade and walls of water-bearing structures.
3. Coil-type shall leave conical depression in concrete.
4. Space as required against pressure of fresh concrete.

C. CHAMFER STRIPS:

1. 3/4-inch chamfer except where otherwise indicated.
2. Place in all forms to provide chamfer where concrete will have exposed projecting corners.

3A-3 PERFORMANCE

A. FORM CONSTRUCTION:

1. Conform to ACI 318 and ACI 347.
2. Adequately brace, stiffen and support forms to prevent perceptible deflection or settlement, and to hold plumb or level and true to line.
3. Construct sufficiently tight to prevent mortar leakage.

3A - FORMS: continued

4. Avoid offsets between adjacent forms and construct so that shores, braces and stiffening members are in line with those below.
5. Space studs and stringers as required to support facing against concrete pressure but not more than 12 inches for 5/8-inch plywood or 16 inches for 3/4-inch plywood.
6. Use wales, strongbacks, shores and bracing as required.
7. Form all necessary openings or chases for piping, ductwork and similar items where indicated or as required for the Work.
8. Construct forms to be removable in sections without marring concrete surface.
9. Surface of forms shall provide smooth, dense, plane surface to finished concrete where exposed to view.
10. Contractor shall be responsible for structural adequacy of formwork.

B. TIME IN PLACE FOR FORMS:

1. No shores, bracing, supports or other formwork shall be loosened or removed until the concrete members supported thereby have acquired sufficient strength to support safely their own weight and any other possible loads.
2. The minimum time between concrete placement and form removal shall be determined either by field-cured test specimens or in accordance with the time specified for the member involved.
3. If Contractor elects to determine the required time by means of test specimens, all costs in connection therewith shall be his responsibility.
4. Test specimens shall be made, field-cured and tested as specified in SECTION 3C. No forms or supports shall be loosened or removed until tests indicate strength of members as follows:

<u>Structural Member</u>	<u>Percent of design compressive or flexural strength</u>
Unshored slab and beam forms for forms which can be removed without disturbing shores	70
Slab or beam shoring	85
Wall, column and beam side forms	40

5. If field-cured test cylinders or beams are not used as the basis for determination of time in place for formwork, the following criteria shall apply:

<u>Structural Member</u>	<u>Time in Place for Forms*</u>
Slab or beam shoring	12 days
Slab forms or beam soffits	7 days
Wall, column and beam side forms	18 hours

* These periods are a cumulative number of days or fractions thereof, not necessarily consecutive, during which the temperature of the concrete surface is above 50 degrees F.

- C. REMOVAL OF FORMS: Remove forms in a manner to avoid damage to the structure, with particular care for corners and edges.

* * * * *

3B - STEEL REINFORCEMENT

3B-1 GENERAL

A. DESCRIPTION:

1. This Section includes steel reinforcement bars, ties, bolsters, chairs supports and accessories.
2. Related Work Specified Elsewhere:
 - a. Concrete: SECTION 3C.
 - b. Forms: SECTION 3A.

B. QUALITY ASSURANCE:

1. Applicable Standards:
 - a. American Society for Testing and Materials (ASTM):
 - (1) A82 - Cold Drawn Wire.
 - (2) A185 - Welded Steel Wire Fabric for Concrete Reinforcement.
 - (3) A615 - Deformed Billet Steel Bars for Concrete Reinforcement.
 - b. American Concrete Institute (ACI):
 - (1) ACI 315 - Manual of Standard Practice for Detailing Reinforced Concrete Structures, as modified by interim reports.
 - (2) ACI 318 - Building Code Requirements for Reinforced Concrete.
 - c. American Welding Society (AWS):
 - (1) AWS D12.1 - Recommended Practice for Welding Reinforcing Steel, Metal Inserts and Connections in Reinforced Concrete Construction.
 - (2) AWS B3.0 - Standard Qualification Procedures for Welders.

C. SUBMITTALS:

1. Compliance Submittals:
 - a. Submit as specified in DIVISION 1.
 - b. Include, but not limited to, the following:
 - (1) Complete bar schedule, bar details and erection drawings to conform to ACI 315.
 - (2) Each type of bar marked with identification corresponding to identification tag on bar.
 - (3) Erection drawings shall be clear, easily legible and to a minimum scale of:
 - (a) 1/4-inch = 1 foot.
 - (b) 1/8-inch = 1 foot if bars in each face are shown in separate views.
 - (4) Size and location of all openings.

D. DELIVERY, STORAGE AND HANDLING:

1. Store steel reinforcement blocked up off the ground and in orderly stacks.
2. Store only bars with the same identifying label in the same stack.

E. TESTING:

1. Perform at the mill for each heat.
2. Submit certified test results to Engineer upon request.

3B - STEEL REINFORCEMENT: continued

3B-2 EQUIPMENT AND MATERIALS

A. REINFORCEMENT BARS, TIES AND STIRRUPS:

1. Materials:
 - a. Conform to ASTM A615, Grade 60 except as otherwise specified.
 - b. Column ties and stirrups of any size and all #3 bars shall conform to ASTM A615, Grade 40 unless otherwise indicated.
 - c. Cold-drawn wire for spiral column ties shall conform to ASTM A82.
2. Fabrication of Bars:
 - a. Fabricate with cold bends conforming to the recommended dimensions shown in ACI 318.
 - b. Field fabrication will be allowed only if Contractor has equipment to properly fabricate steel.
 - c. Attach metal tags with identifying mark.
 - d. Contractor may at his option continue steel reinforcement through openings in walls and slabs, then field-cut the opening.

B. WELDED WIRE FABRIC:

1. Conform to ASTM A185 using bright basic wire conforming to ASTM A82.
2. Wire gauges #11 and smaller shall be galvanized.

C. BOLSTERS, CHAIRS AND ACCESSORIES:

1. Conform to ACI 315 and the Manual of Standard Practices of the Concrete Reinforcing Steel Institute.
2. Provide all spacers, bolsters, chairs, ties, and other devices necessary to properly space, place, support and fasten steel reinforcement in place during the concrete placement.
3. Metal accessories shall be galvanized or plastic coated where legs will be exposed in finished concrete surfaces.
4. Do not use rocks, broken bricks, wood blocks, or concrete fragments for support of steel reinforcement.

D. PRECAST CONCRETE BLOCK BAR SUPPORTS:

1. May be used only for bar supports in slabs on ground.
2. Blocks shall be made with a minimum of nine sacks of cement per cubic yard and have a compressive strength of 6,000 psi in seven days.
3. Each block shall have a minimum of 9 square inches of bearing area. Space as required by the particular condition of weight, bearing surface and rigidity of the steel reinforcement.

3B-3 PERFORMANCE

A. PLACEMENT OF STEEL REINFORCEMENT:

1. Place in accordance with Chapter 7 of ACI 318 and the Manual of Standard Practice of the Concrete Reinforcing Steel Institute.
2. Tie securely with 16-gauge or larger annealed iron wire.
3. Place to maintain concrete to conform to Article 7.14 of ACI 318 unless otherwise indicated.
4. Splice steel to conform to Chapter 7 of ACI 318.

3B - STEEL REINFORCEMENT: continued

- a. Lapped splices shall be not less than 30-bar diameters for A615, Grade 40 steel or 42-bar diameters for A615, Grade 60 steel unless otherwise indicated.
 - b. Use arc-weld splices:
 - (1) For bar sizes No. 14 and No. 18.
 - (2) For bars smaller than No. 14 where indicated.
 - (3) In other locations at Contractor's option.
 - c. Cadweld splices may be used as an alternative to arc-welded splices.
 - d. Arc-welds shall be full penetration butt welds using low-hydrogen type electrodes of Class AWS A5.5 Class E90XX-D1, G or M for shielded metal-arc welding.
5. Lap welded wire fabric not less than the length of one mesh plus 2 inches unless otherwise indicated.

* * * * *

3C - CONCRETE

3C-1 GENERAL

A. DESCRIPTION:

1. This Section includes concrete for all structures and equipment foundations indicated, grout, expansion materials, and moisture barrier.
2. Related Work Specified Elsewhere:
 - a. Forms: SECTION 3A.
 - b. Steel Reinforcement: SECTION 3B.

B. QUALITY ASSURANCE:

1. Applicable Standards:
 - a. American Society for Testing and Materials (ASTM):
 - (1) C31 - Making and Curing Concrete Compression and Flexure Test Specimens in the Field.
 - (2) C33 - Concrete Aggregates.
 - (3) C39 - Compressive Strength of Cylindrical Concrete Specimens.
 - (4) C40 - Organic Impurities in Sands for Concrete.
 - (5) C42 - Obtaining and Testing Drilled Cores and Sawed Beams of Concrete.
 - (6) C78 - Test for Flexural Strength of Concrete (Using Simple Beam with Third-Point Loading).
 - (7) C88 - Soundness of Aggregates by Use of Sodium Sulfate or Magnesium Sulfate.
 - (8) C94 - Ready-Mixed Concrete.
 - (9) C143 - Slump of Portland Cement Concrete.
 - (10) C150 - Portland Cement.
 - (11) C172 - Sampling Fresh Concrete.
 - (12) C192 - Making and Curing Concrete Test Specimens in the Laboratory.
 - (13) C231 - Air Content of Freshly Mixed Concrete by the Pressure Method.
 - (14) C233 - Testing Air-Entraining Admixtures for Concrete.
 - (15) C260 - Air-Entraining Admixtures for Concrete.
 - (16) C309 - Liquid Membrane-Forming Compounds for Curing Concrete.
 - (17) C494 - Chemical Admixtures for Concrete.
 - (18) D1752 - Preformed Expansion Joint Fillers for Concrete.
 - b. American Concrete Institute (ACI):
 - (1) ACI 211.1 - Recommended Practice for Selecting Proportions for Normal and Heavyweight Concrete.
 - (2) ACI 211.2 - Recommended Practice for Selecting Proportions for Structural Lightweight Concrete.
 - (3) ACI 214 - Recommended Practice for Evaluation of Compression Test Results of Field Concrete.
 - (4) ACI 304 - Recommended Practice for Measuring, Mixing, Transporting and Placing Concrete.
 - (5) ACI 305 - Recommended Practice for Hot-Weather Concreting.
 - (6) ACI 306 - Recommended Practice for Cold-Weather Concreting.
 - (7) ACI 309 - Recommended Practice for Consolidation of Concrete.
 - (8) ACI 318 - Building Code Requirements for Reinforced Concrete.
 - (9) ACI 506 - Recommended Practice for Shotcreting.
 - c. Associated General Contractors (AGC) of America, Mixer Manufacturers Bureau Concrete Mixer Standards.
 - d. National Bureau of Standards (NBS) Specifications for Scales.

3C - CONCRETE: continued

- e. National Ready-Mix Concrete Association, "Truck Mixer, and Agitator Standards of the Truck Mixer Manufacturers' Bureau."
- 2. Acceptable Manufacturers: Specified in PART 3C-2.

C. SUBMITTALS:

- 1. Compliance Submittals:
 - a. Submit as specified in DIVISION 1.
 - b. Includes, but not limited to, the following:
 - (1) Grouts.
 - (2) Expansion joint materials.
 - (3) Sealants.
 - (4) Waterstops.
 - (5) Moisture barrier.
- 2. Test Reports:
 - a. Submit as specified in DIVISION 1 and PART 3C-2.

- D. DELIVERY, STORAGE AND HANDLING: Handle and store all materials as specified in DIVISION 1 and PART 3C-2.

3C-2 EQUIPMENT AND MATERIALS

A. COMPOSITION OF CONCRETE:

- 1. Portland cement.
- 2. Fine aggregate.
- 3. Coarse aggregate.
- 4. Mixing water.
- 5. Water-reducing-type admixture.
- 6. Air-entraining-type admixture.
- 7. Set-retarding-type admixture, when required.

B. CONCRETE MATERIALS:

- 1. Cement:
 - a. Portland Cement Type I. Conform to ASTM C150.
 - b. Perform testing at the mill for each carload and furnish certified test results to Engineer upon request.
 - c. Ship cement in suitable bags or in properly designed trucks or rail cars for bulk cement.
 - d. Store cement in stacks not more than 5 bags high, 12 inches minimum from walls or ground, or in suitable bins or silos for bulk cement.
 - e. Protect from dampness and foreign materials.
- 2. Fine Aggregate:
 - a. Conform to ASTM C33.
 - (1) Approved service record of at least 3 years.
 - (2) Limits of fineness modulus shall be 2.5 to 3.1.
 - b. Store aggregates in a manner to prevent intrusion of foreign matter and permit free drainage. Storage on ground will be permitted if bottom 6 inches of pile is discarded.
- 3. Coarse Aggregate:
 - a. Crushed stone or processed natural gravel containing no organic materials.
 - b. Conform to ASTM C33.

3C - CONCRETE: continued

- (1) Approved service record of at least 3 years.
 - (2) Loss of weight shall not exceed 12 percent after five cycles of sodium sulfate soundness test.
 - (3) Grading Requirements:
 - (a) From 1-inch to No. 4 for all concrete unless otherwise specified.
 - c. Batching Requirements:
 - (1) Coarse aggregate which includes any size larger than 1 inch shall be batched in not less than two bins with larger sizes separated from smaller sizes.
 - (2) Prevent aggregate segregation after final screening by handling to conform to ACI 304.
 - d. Store aggregate in a manner to prevent intrusion of foreign matter and permit free drainage. Storage on ground will be permitted if bottom 6 inches of pile is discarded.
4. Mixing Water:
- a. Only potable water will be acceptable without testing.
 - b. Clean and free from injurious amounts of oil, acids, alkalies, organic materials, or other deleterious substances.
 - c. Shall produce concrete with at least 95 percent of the strength of similar specimens made with water selected by Engineer.
5. Admixtures:
- a. Water Reducing Type:
 - (1) Conform to ASTM C494, Type A.
 - (2) Conform to manufacturer's recommendations for use.
 - (3) Approved service record of at least 5 years.
 - (4) Technical assistance of the manufacturer's field representative shall be furnished upon request.
 - b. Air-Entraining Type:
 - (1) Conform to ASTM C260.
 - (2) Approved service record of at least 5 years.
 - (3) Conform to manufacturer's recommendations for use.
 - (4) Technical assistance of the manufacturer's field representative shall be furnished upon request.
 - (5) Testing of air-entraining admixtures shall conform to ASTM C233.
 - c. Other Admixtures: Used only with Engineer's written concurrence.
- C. LABORATORY TESTING OF MATERIALS FOR USE IN CONCRETE:
1. An approved independent testing laboratory shall be selected and paid by Contractor to perform all required laboratory tests of materials proposed for use in the production of concrete and to determine mix proportions when laboratory trial batches are required.
 2. The laboratory shall report the results of the testing and mix designs as follows:
 - a. Engineer, Kansas City Office (1 copy).
 - b. Resident Project Representative, Field Office (1 copy).
 - c. Contractor (copies as required).
 - d. Concrete supplier (copies as required).
 3. Contractor shall deliver representative samples of all proposed concrete materials to the laboratory for the following testing:
 - a. Fine Aggregate:
 - (1) ASTM C33 as amended by Paragraph B2.

3C - CONCRETE: continued

- (2) ASTM C40.
- (3) ASTM C88.
- b. Coarse Aggregate:
 - (1) ASTM C33 as amended by Paragraph B3.
 - (2) ASTM C88.
- c. Mixing water, if other than potable water is proposed for use and in the opinion of Engineer there is reason to suspect its acceptability:
 - (1) With the design mix the laboratory shall make two concrete test cylinders using proposed water and two concrete test cylinders using potable water conforming to ASTM C192.
 - (2) All cylinders shall be tested conforming to ASTM C39. Age of cylinders at test shall be 28 days unless an earlier age is authorized.

D. CONCRETE QUALITIES REQUIRED:

- 1. Compressive Strength:
 - a. Minimum 28-day strength = 4000 psi for all construction unless otherwise indicated.
 - b. Minimum 28-day strength = 3000 psi for fill concrete and seal coats.
- 2. Slump of concrete shall be $3\frac{1}{2}$ inches plus or minus 1 inch.
- 3. Air Content:
 - a. $\frac{3}{4}$ - to 1-inch maximum size aggregate: 5 to 7 percent.

E. CONCRETE MIX PROPORTIONS:

- 1. Concrete shall be homogeneous, readily placeable and uniformly workable; proportioned to conform to ACI 211.1.
- 2. Mix proportions for all concrete unless otherwise specified shall be selected preferably on the basis of field experience; but in the case where sufficient or suitable strength test data is not available, concrete shall be proportioned on the basis of laboratory trial mix design.
 - a. Field experience using test results within the preceding 90 days with the materials to be employed may be the basis of mix proportioning provided that not less than 30 consecutive satisfactory compressive strength tests on concrete using the proposed materials with a similar mix are available. A compressive strength test is defined as the average 28-day compressive strength of two companion cylinders made conforming to ASTM C172 and ASTM C31 and tested conforming to ASTM C39. The standard deviation of such tests shall be computed as a basis for design of the mix. The design average strength shall exceed the specified strength in accordance with the following formulae:
 - (1) When standard deviation is less than 500 psi,
Design Average Strength = Specified Minimum Strength + 1.343
x Standard Deviation.
 - (2) When standard deviation is greater than 500 psi,
Design Average Strength = Specified Minimum Strength - 500 + 2.326
x Standard Deviation.
 - (3) Submit previous test data, calculated standard deviation, and the proposed mix proportions to Engineer for approval prior to placing concrete.

3C - CONCRETE: continued

- b. When laboratory trial batches are used as a basis for determining mix proportions, all such work shall be performed by the laboratory specified in Article C, this Part.
 - (1) Laboratory trial batches shall be used to establish a water-cement ratio compression strength curve with at least three points, each representing the strength of a separate trial batch. At least one point shall be above and one below the strength required. Each point on the curve shall represent the average of at least three specimens tested at 28 days or an earlier age when approved by Engineer. The slump and air content shall be at the maximum limits specified in Article D, this Part.
 - (2) A point on the water-cement ratio compressive strength curve shall be selected that will provide an average strength at least 1200 psi greater than the specified minimum strength.
 - (3) Laboratory reports establishing mix proportions shall be sent to Engineer, and his approval obtained prior to placing all concrete.

F. MEASUREMENT OF MATERIALS:

- 1. General Requirements:
 - a. Conform with ACI 304.
 - b. Measure materials within one percent by weight for aggregates and cement, and within 1½ percent by volume or weight for water.
- 2. Apparatus:
 - a. Beam or springless dial-type scale conforming with NBS - "Specifications for Scales."
 - b. Volumetric measurement of water shall be performed with an approved automatic valve.

G. MIXING OF CONCRETE:

- 1. Conform to ACI 304.
- 2. Mixer:
 - a. Conform to Mixer Manufacturers Bureau Concrete Mixer Standards, AGC, adequate to handle one or more full-sack batches.
 - b. Charge with 5 percent to 10 percent of the mixing water both in advance and after the addition of aggregates and cement.
 - c. Charge with remaining water uniformly with the other materials.
 - d. Avoid charging in excess of manufacturer's rating.
 - e. Discharge mixed concrete completely prior to recharging.
- 3. Mixing Time:
 - a. Start immediately when all ingredients except the last of the water are in the mixer.
 - b. Minimum mixing time shall conform with mixer manufacturer's instructions, but be not less than the following:

<u>Capacity of Mixer</u> <u>Cubic Yards</u>	<u>Minimum Time of</u> <u>Mixing, Minutes</u>
1 or less	1 minute
2	1¼
3	1½
4	1-3/4
5	2
6	2¼

Add 15 seconds' mixing time for each additional cubic yard of concrete.

3C - CONCRETE: continued

4. Mixing of Concrete at Plant Off Jobsite:

- a. Mix concrete in central mixer or truck mixer. Transport in truck mixer turning at agitation speeds only.
- b. Water added to concrete having a slump below the specified minimum shall be at Contractor's risk. If the water added produces a slump greater than the specified maximum, the concrete will be rejected.
- c. Truck mixer shall conform to "Truck Mixer and Agitator Standards of the Truck Mixer Manufacturers Bureau," of the National Ready-Mix Concrete Association.
- d. Ready-mixed concrete shall be produced and delivered conforming to ASTM C94 as applicable.
- e. Contractor shall furnish Engineer with a concrete delivery ticket for each load of concrete. The ticket shall have the following information recorded:
 - (1) Ticket number.
 - (2) Time batched.
 - (3) Time arrived on jobsite.
 - (4) Amount of rock, sand, cement, and water (total).
 - (5) Mix number.
 - (6) Amount of all water added at jobsite by Contractor.

H. GROUT:

1. Plain Grout:

- a. 1 part portland cement to 2 parts sand by volume.
- b. Keep water to a minimum as required for placing by the dry packing method.
- c. Place after the mixed grout has been allowed to stand for two hours.
- d. The sand and cement shall be as specified for concrete.

2. Nonshrinking Grout:

- a. Required for setting handrail posts, for setting equipment recommended by the manufacturer to be set with nonshrinking grout, and in other places indicated.
- b. Grout shall be as manufactured by one of the following:
 - (1) Masterflow 713 grout, Master Builder's Company, Cleveland, Ohio.
 - (2) Saurereisen F-100, Saurereisen Cements Company of Pittsburgh, Pennsylvania.
 - (3) Five Star grout, U. S. Grout Corporation of Old Greenwich, Connecticut.
- c. Prepare and place conforming to manufacturer's written instructions.

3. Grout for Bonding:

- a. 1 part cement to 1½ parts sand by weight.
- b. Keep water to a minimum.
- c. Place immediately.

I. CONCRETE ACCESSORIES:

1. Water Stops:

- a. Serrated polyvinyl chloride equal to one of the following:
 - (1) Servicized/Durajoint Type 13, W.R. Grace Company.
 - (2) Vulco VP 1300, Vulcan Metal Products Company.
- b. Water Stop Sealant: Two component polysulfide system as manufactured by one of the following:
 - (1) Hornflex L, W. R. Grace Company.
 - (2) Sikaflex Polysulfide Sealant, Sika Chemical Corporation.
 - (3) Synthacalk GC-2, Pecora, Inc.

PHSIKEMO(33)
052378

3C - CONCRETE: continued

2. Expansion Joints and Joint Fillers:
 - a. Expansion Joint Filler: Premolded cork of thickness indicated and conforming to ASTM D1752, Type II.
 - b. Polyurethane Joint Filler: Closed cell expansion joint filler - Rescor or approved equal.
 - c. Construction Adhesive:
 - (1) Shall be compatible to joint filler, neoprene bearing pad and concrete bonding-surface.
 - (2) Equal to Tuff-Bond No. 90 manufactured by Goodloe E. Moore Co., Danville, Illinois.
 - d. Bond Breaker: Cover completely the vertical and horizontal edges of the joint filler with polyethylene strip prior to sealing joint.
 - e. Sealant:
 - (1) Shall be a two-component Epoxy Base Pourable Sealant equal to Para-Caulk, manufactured by Parawax Company, Council Bluffs, Iowa.
3. Preformed Contraction Joints: QUICK JOINT T-shaped plastic strip as manufactured by Quickjoint of LaHabra, California.
4. Dovetail Anchor Slots: 24-gauge zinc alloy, 1-inch wide back x 1-inch deep x 5/8-inch throat as manufactured by one of the following:
 - a. Heckmann Building Products, Inc.
 - b. Hohmann & Barnard, Inc.
 - c. Gateway Products.

3C-3 PERFORMANCE

A. FIELD TESTING:

1. Field Testing of Concrete and Making of Concrete Test Cylinders:
 - a. Contractor shall furnish test equipment and trained personnel to perform all required field tests and make the required concrete test cylinders. The prescribed tests shall be made in the presence of or with the concurrence of Engineer.
 - b. Concrete sampling for tests and cylinder making shall be done conforming to ASTM C172.
 - c. Perform slump tests conforming to ASTM C143 to maintain control of quality.
 - d. Remove aggregate larger than 1½ inches, by wet screening through a screen having 1½-inch square openings, from all samples prior to slump tests.
 - e. Perform air tests conforming to ASTM C231.
 - f. Prepare concrete test cylinders for laboratory testing as follows:
 - (1) Obtain cylinder molds from the laboratory.
 - (2) Do not use concrete used in making slump or air tests.
 - (3) Remove aggregate larger than 1½ inches from sample.
 - (4) Make not less than one set of cylinders (6 cylinders) from each day's pour for each 150 cubic yards of concrete or fraction thereof nor less than one set for each 5,000 square feet of slab top surface area.

- (5) Test cylinders shall be made and cured for the first 24 hours in accordance with ASTM C31.
 - (6) Pack cylinders in crates padded with foam rubber or damp sawdust. Keep continuously moist and at proper temperature during transit and deliver to laboratory designated by Owner immediately after the one-day "on-the-jobsite" curing period.
2. Preparation and Testing of Field-Cured Test Cylinders and Beams:
- a. In addition to concrete test cylinders specified in the preceding Article, Contractor may prepare cylinders or beams to be field-cured and tested as a basis for determining time in place for formwork.
 - b. Cure field-cured test cylinders or beams on the project site under the same conditions as the concrete which the test specimens represent until proposed time of form removal.
 - c. Deliver concrete cylinders to the laboratory for immediate testing.
 - d. Field-cured flexural test specimens (beams) may be delivered to the laboratory for testing or may be tested at the jobsite on test apparatus furnished by Contractor.
 - e. Field testing of flexural test specimens shall conform to ASTM C78 and be observed by Engineer. Design flexural strength shall be 20 percent of the specified design compressive strength.
 - f. The average strength of two cylinders or beams of the same age shall be considered as one test.
3. Laboratory Testing of Concrete During Construction:
- a. An independent testing laboratory will be selected and paid by Owner to perform the required laboratory tests and statistical evaluations of concrete being used in the work.
 - b. The laboratory will report the results of all testing and statistical evaluations as specified in DIVISION 1.
 - (1) Engineer, Kansas City Office (1 copy).
 - (2) Resident Project Representative, Field Office (1 copy).
 - (3) Contractor (2 copies).
 - (4) Concrete Supplier (1 copy).
 - c. Testing Field-Made Concrete Test Cylinders:
 - (1) The laboratory shall start curing the test cylinders conforming to ASTM C192 immediately upon receipt from Contractor.
 - (2) The laboratory shall test all cylinders conforming to ASTM C39, testing two at 7 days of age and two at 28 days of age. The average strength of the two cylinders (same age) shall be used as the result of the test.
 - (3) When the average compressive strength of the two 7-day tests is less than 70 percent of the specified minimum 28-day compressive strength, two cylinders shall be tested at 14 days.
 - (4) If the average strength of the two 14-day tests is less than 85 percent of the minimum 28-day compressive strength, the Contractor may, at his discretion and expense, and with Engineer's approval, take field cores on the 15th day after placement of the potentially low-strength concrete and within 24 hours have the laboratory test these cores (ASTM C42). The potentially low-strength concrete

3C - CONCRETE: continued

will be accepted if the average of the core tests is 85 percent or greater of the specified 28-day compressive strength.

- (5) Contractor may, at his expense, make additional cylinders and have 3-day compression tests made of critical concrete placements where an early knowledge of strength is beneficial.
4. Compliance With Strength Provisions:
 - a. The laboratory shall maintain and submit with each test report a current statistical evaluation (average strength and standard deviation - ACI 214) of the concrete quality, starting when ten each of 7- and 28-day tests have been performed. The evaluation shall be based on a moving average of the latest 10 test results.
 - (1) Should the statistical data indicate an unacceptable combination of average strength and standard deviation, Contractor shall take immediate corrective action. Noncompliance after two warnings from Engineer will be sufficient to refuse additional concrete from the noncomplying concrete supplier.
 - (2) Should the statistical data indicate an excessive margin of safety, the concrete mix may be modified subject to approval.
 - b. Contractor shall have the right to observe all phases of concrete cylinder curing and testing. Should Contractor observe any deviations from the prescribed testing procedures that he considers detrimental to concrete strength test results, he shall immediately notify Engineer in writing so that corrective measures may be taken.

B. LOW-STRENGTH CONCRETE:

1. Low-Strength Concrete:
 - a. Defined as concrete whose 28-day test (average of two cylinder breaks) is less than the minimum 28-day strength required.
 - b. Additional curing and tests, if required by Engineer, shall be performed by Contractor at Contractor's expense.
 - c. Remove and replace with acceptable concrete when the quality and location of the low-strength concrete is such that Engineer considers the strength or durability of the structure is impaired and so orders.
2. Potentially Low-Strength Concrete:
 - a. Defined as concrete whose 7-day and 14-day test (average of two cylinders) is less than 70 percent and 85 percent respectively of the specified minimum 28-day compressive strength. The designated percentage for strength shall be adjusted if the history of the cement being used in the concrete mix produces a higher or lower compressive strength at the 7-day and 14-day tests.
 - b. Potentially low-strength concrete shall remain accessible with no other work performed that relates to, or depends upon, the questionable concrete until a final decision as to the disposition of the concrete is made by Engineer.
3. Construction delays caused by low-strength or potentially low-strength concrete shall not relieve Contractor from liquidated damages for late completion even though extensions of time may be granted.

3C - CONCRETE: continued

C. HOT-WEATHER CONCRETING:

1. Conform to ACI 305 when temperature is 90 degrees F or above, or is likely to rise above 90 degrees F within the 24-hour period after placing.
2. Concrete shall have an in-place temperature 85 degrees F or lower.
3. Cool concrete by shading and water fogging for a minimum period of 24 hours, starting immediately after placing.

D. COLD-WEATHER CONCRETING:

1. Conform to ACI 306 when the temperature is below 40 degrees F or is likely to fall below 40 degrees F during the 24-hour period after placing.
2. Do not expose fresh concrete to carbon monoxide or carbon dioxide fumes from heaters or engines.
3. Place concrete in temperatures recommended in Table I of ACI 306.

E. PLACING OF CONCRETE:

1. General Requirements:
 - a. Conform to ACI 304.
 - b. Bonding surfaces shall be clean, free of laitance and foreign materials.
 - c. Face horizontal bonding surfaces with 1-inch-thick coat of fresh "grout for bonding," wet all other surfaces.
 - d. Place concrete on properly prepared and unfrozen subgrade and only in dewatered excavation and forms.
 - e. Use forms for all concrete except where otherwise indicated or specified.
 - f. Avoid placing concrete that has partially hardened or has been contaminated by foreign materials.
 - g. Prevent mud or foreign materials from entering the concrete or forms during placement operations.
2. Conveying:
 - a. Convey concrete from the mixer and deposit in place by methods which will prevent the segregation or loss of materials.
 - b. Equipment for chuting, pumping, and pneumatically conveying concrete shall be of such size and design as to provide a practically continuous flow of concrete at the delivery end.
 - c. Aluminum conveying equipment shall not be used.
3. Depositing:
 - a. Place concrete in continuous horizontal lifts not to exceed 18 inches, and place concrete against bulkheads and keyways at vertical joints.
 - b. Maximum free drop of concrete shall be 5 feet in walls 10 inches or less in thickness with 1-foot additional drop allowed for each inch of wall thickness over 10 inches, with a maximum drop of 10'-0".
 - c. When moisture barrier is used, keep lapped joints closed and take precautions to avoid puncturing the barrier.
4. Consolidation of Concrete:
 - a. Consolidate concrete in conformance with ACI 309. Characteristics and application of concrete vibrators shall be as set forth in Table I of the Report.

3C - CONCRETE: continued

- b. Provide an adequate number of vibrators of sufficient capacity to keep up with the maximum rate of concrete placement. Keep on hand adequate standby equipment in good condition.
 - c. Vibrate concrete only until the concrete is thoroughly consolidated and the voids filled as evidenced by the leveled appearance of the concrete at the exposed surface and the embedment of the surface aggregate.
 - d. Insert internal vibrators vertically to the full depth of the layer being placed and into the previous layer where not hardened. Do not drag vibrators through the concrete. Insert and withdraw vibrator slowly with the vibrator running continuously so that no hole will be left in the concrete. Avoid flow of concrete from one location to another by use of a vibrator.
 - e. Consolidate concrete layer to full depth when using a surface vibrator. Use thinner layers or more powerful vibrator if necessary to achieve complete consolidation.
 - f. Use form vibrators only where sections are too thin or where sections are inaccessible for internal vibrators.
5. Time Requirements:
- a. Place concrete at a sufficient rate to assure that lifts below have not taken initial set before fresh concrete is deposited.
 - b. Place concrete within forty-five minutes after mixing, except that this period may be extended to ninety minutes maximum if weather conditions are favorable and Engineer concurs.
- F. CURING OF CONCRETE: Cure all concrete by one of the following methods:
- 1. Leaving in forms for a minimum of 7 days. Keep formwork wet to prevent drying of concrete surfaces.
 - 2. Use of saturated bats, soaker hoses, or sprinkler for a minimum of 7 days. Keep concrete continuously wet.
 - 3. Using one coat of a liquid membrane forming compound conforming to ASTM C309, Type 1. Curing compound used on floors to be painted or tiled shall be guaranteed not to interfere with application of paint or adhesives for tile after 28-day curing period. Curing compound shall be applied immediately after removal of forms (which have been continuously wet); or in case of a slab, after the concrete has been finished and is hardened sufficiently to walk on.
 - 4. Using polyethylene sheets applied in full contact with surfaces, and maintain in an approved manner for a minimum of 7 days.
 - 5. The curing methods recommended in ACI 305 and ACI 306 shall be followed for concrete placed during hot or cold weather.
- G. JOINTS:
- 1. Construction Joints:
 - a. Location:
 - (1) Locate joints not indicated or specified to least impair the strength of the structure.

3C - CONCRETE: continued

- (a) Locate construction joints in floors, beams, and girders of "Cast-in-place" construction near the center of spans except that if a beam intersects a girder at this point, the joint in the girder shall be offset a distance equal to twice the beam width and adequate shear reinforcement shall be provided.
 - (b) Construction joints in slabs supported on either steel or pre-cast concrete beams may be located near midspan or on the beam center line provided shear studs or other embedded items do not make this impractical.
 - (c) Locate joints to limit the length of all concrete placements to not more than 40'-0", except as indicated.
 - (2) Obtain Engineer's approval of joints located by Contractor prior to preparation of reinforcing steel drawings.
 - b. Preparation of Construction Joints:
 - (1) Clean and break laitance or other foreign material from bonding surface.
 - (2) Bed horizontal joints with 1 inch of grout for bonding.
 - (3) Tighten forms remaining in place (where applicable) to prevent seepage between forms and hardened concrete.
 - c. Construction of Joints:
 - (1) Provide water stops and shear keys as indicated or specified and as required in any new construction joint requested by Contractor.
 - (2) Delay construction at a joint a minimum of sixteen hours where placement is continued past joint except where otherwise indicated or approved.
 - (3) Take precautions to insure tight, well-bonded construction joints with no air pockets or voids.
 - d. Water Stops:
 - (1) Install in all construction joints where indicated.
 - (2) Install conforming to manufacturer's printed instructions. Take special precautions to avoid bending or displacing water stop while placing concrete around it.
 - (3) Use elastomeric water stops where indicated. Clean and prime the joint surfaces prior to installing the water stop material.
 2. Expansion Joints:
 - a. Location: As indicated.
 - b. Install expansion joint filler of premolded cork of the thickness indicated.
 - c. Cover completely the top surface of the joint filler with a poly-ethylene strip bond breaker prior to sealing joint.
 - d. Seal top ½-inch of expansion joint with joint sealing compound applied conforming to manufacturer's instructions.
- H. OPENINGS AND INSERTS IN CONCRETE:
1. Openings Through Concrete: Provide openings through concrete as indicated and for the proper installation of all equipment, piping, wiring, ductwork and similar items, installed under this contract.
 2. Installation of Embedded Items:
 - a. Provide for accurate installation of edge plates, inserts, sleeves, conduit, anchors, bolts, angle guards, stair nosings, dowels, floor drains, equipment drains, thimbles, anchor slots, metal reglets,

3C - CONCRETE: continued

- nailing strips, blocking grounds, and other devices as indicated and as required for items installed under this Contract.
- b. Securely fix floor drains in place to prevent flotation while placing concrete. Uniformly and accurately slope finish floor slab toward the drains.
 - c. Install flashing reglets in locations as indicated.
 - d. Install dovetail anchor slots in concrete walls, columns, and beams, requiring a masonry finish. Install anchor slots vertically spaced on 2-foot centers.
 - e. Concrete Inserts:
 - (1) Install concrete inserts where indicated or as required for piping, equipment, and other items installed under this contract.
 - (2) Concrete inserts shall be as specified in other DIVISIONS, or if not so specified, as selected by Contractor and approved by Engineer.

I. FINISHES:

1. Slab Finish:

a. Screeding:

- (1) Use screed of true undeflected straightedge with screed rails set true and adequately braced.
- (2) Screed shall be constantly carried on rails, never lifted to reduce load.
- (3) Immediately after concrete placement, recheck screed rails for proper elevation.

b. Hard-Troweled Finish:

- (1) Use on all floors and other unformed surfaces unless otherwise specified or indicated.
- (2) Float with mechanical float. Hand floating will be permitted only in areas inaccessible to mechanical float.
- (3) Test surface with straightedge and eliminate high or low spots exceeding 1/8-inch in 10 feet, except at floor drains.
- (4) Avoid excessive working of the concrete and particularly avoid troweling before surface water has disappeared.
- (5) Trowel with steel trowel (mechanical or hand) to obtain a smooth, dense finish after concrete has hardened to ring under trowel.
- (6) Do not add sand or cement to the floor surface.

c. Float Finish:

- (1) Top surface of bridge decks shall have wood-float finish.

d. Broom Finish:

- (1) Use on all outdoor slabs such as pavement, sidewalks, and in other areas indicated.
- (2) Perform as float finish except that in addition the surface shall have a stiff-bristle broom drawn across the previously finished surface.
- (3) Finish so that corrugations will be uniform in appearance, not more than 1/16 inch in depth, and perpendicular to the direction of traffic.

3C - CONCRETE: continued

J. DEFECTIVE SURFACES:

1. Definition: Defined as any concrete surface showing misalignment, rock pockets, poor joints, holes from ties, voids, honeycomb, or any other defective area.
2. Repairing:
 - a. Chip surface back to minimum depth of one-half inch, chip edges perpendicular to surface, prewet depression and brush with neat cement immediately before patching.
 - b. Patch surfaces using mortar with same sand-cement ratio as original concrete and with minimum water for placing. Use approximately 20 percent white cement to match concrete color. Allow mortar to stand one hour before using.
 - c. Compact mortar into depressions, leaving mortar slightly higher than surface for one hour. Strike mortar flush with surface.
 - d. Apply mortar to tie holes with hammer and ramming rod and strike flush with surface.
 - e. Moist-cure for 3 days or use curing compound.

K. EQUIPMENT BASES:

1. Construct equipment bases, pads, and foundations as indicated for all equipment installed under this Contract or, when not indicated, conforming to equipment manufacturer's requirements.
2. Reinforce conforming to typical detail unless otherwise indicated.
3. Equipment bases shall include concrete, reinforcing steel, form work as required, anchor bolts, and grout for equipment installed under this contract.
4. Finish top area of bases from anchor bolts to forms with a steel-troweled finish.

* * * * *

3D - PRECAST CONCRETE BRIDGE UNITS

3D-1 GENERAL

A. DESCRIPTION:

1. This Section includes precast and concrete deck for bridge.
2. Related Work Specified Elsewhere:
 - a. SECTION 3B - Metal Reinforcement.
 - b. SECTION 3C - Concrete.

B. QUALITY ASSURANCE:

1. Applicable Standards:
 - a. American Association of State Highway and Transportation Officials (AASHTO), Standard Specifications for Highway Bridges.
 - b. Prestressed Concrete Institute (PCI) MNL-116-70 Manual for Quality Control for Plants and Production of Precast, Prestressed Concrete Products.
2. Manufacturer of prestressed units shall be:
 - a. Featherlite Pre-Cast Corp., Memphis, Tennessee, Choctaw, Inc., Montgomery, Alabama or approved equal.
 - b. Previously experienced in the manufacture of precast members similar to those indicated for at least three years.

C. COMPLIANCE SUBMITTALS:

1. Submit as specified in DIVISION 1.
2. Show the erection plan, connection details, fabrication details, reinforcing steel, pick-up points, and all related details for complete installation.
3. Submit design calculations or certification that the load capacity of the precast units equals or exceeds the indicated shear and moment values.

D. DELIVERY, STORAGE AND HANDLING:

1. Shall conform to the requirements of PCI, MNL-116-70.
2. All necessary permits for transportation routes and methods shall be secured by and at the expense of the Contractor.
3. All members shall be inspected prior to unloading and any member that has been excessively damaged in transit will be rejected.

3D-2 MATERIALS

- A. CONCRETE: Shall conform to SECTION 3C.
- B. REINFORCEMENT: Shall conform to SECTION 3B.

3D-3 PERFORMANCE

A. FABRICATION:

1. Production procedures for the manufacture of precast girders shall be in accordance with PCI, MNL-117-70.
2. Dimensional tolerance shall conform to PCI, MNL-116-70.

3D - PRECAST CONCRETE BRIDGE UNITS: continued

3. Finish:

- a. Precast units shall have straight, true edges and surfaces free from honeycomb or voids.
- b. Top surface shall have wood-float finish.
- c. Underside of members shall have smooth finish as derived from steel forms.

B. ERECTION:

1. Erect in accordance with the applicable provisions of PCI and AASHTO. Handle precast units in such manner to prevent excessive stresses or damage from chipping, cracking, etc.
2. Install members according to details on approved compliance submittals, in such manner that will prevent excessive bending about either axis.
3. Members shall be erected by experienced workmen and set in position within allowable tolerance by crane, lifting only at approved pick-up points.
4. Anchorage shall be as indicated.
5. Precast units that are damaged during erection such that their structural integrity is impaired will be rejected. Minor spalls shall be repaired subject to Engineer's approval.

* * * * *

3E - PRESTRESSED, PRECAST CONCRETE BRIDGE GIRDERS

3E-1 GENERAL

A. DESCRIPTION:

1. This Section includes precast, prestressed concrete girders for roadway bridge.
2. Related Work Specified Elsewhere:
 - a. SECTION 3A - Forms.
 - b. SECTION 3B - Metal Reinforcement.
 - c. SECTION 3C - Concrete.

B. QUALITY ASSURANCE:

1. Applicable Standards:
 - a. American Society for Testing and Materials (ASTM):
 - (1) A416 - Uncoated Seven-Wire Stress Relieved Strand, Grade 270 with $\frac{1}{2}$ " nominal diameter.
 - b. American Association of State Highway and Transportation Officials (AASHTO), Standard Specifications for Highway Bridges.
 - c. Prestressed Concrete Institute (PCI) MNL-116-70 Manual for Quality Control for Plants and Production of Precast, Prestressed Concrete Products.
2. Manufacturer of prestressed units shall be:
 - a. Stites Concrete, Inc., Dexter, Missouri or approved equal.
 - b. An active member of the Prestressed Concrete Institute, certified under the PCI Plant Certification Program.
 - c. Previously experienced in the manufacture of precast, prestressed members similar to those indicated for at least three years.

C. COMPLIANCE SUBMITTALS:

1. Submit as specified in DIVISION 1.
2. Show the erection plan, connection details, fabrication details, prestressing strands, reinforcing steel, pick-up points, camber and all related details for complete installation.

D. DELIVERY, STORAGE AND HANDLING:

1. Shall conform to the requirements of PCI, MNL-116-70.
2. All necessary permits for transportation routes and methods shall be secured by and at the expense of the Contractor.
3. All members shall be inspected prior to unloading and any member that has been excessively damaged in transit will be rejected.

3E-2 MATERIALS

A. CONCRETE: Shall conform to SECTION 3C except as follows:

1. Concrete strength:
 - a. 4,000 psi at transfer of prestressing force.
 - b. 5,000 psi at 28 days.
2. Air entrainment: 4 to 6 percent.
3. Concrete shall use normal weight aggregate.

B. REINFORCEMENT: Shall conform to SECTION 3B with the addition of ASTM A416.

3E - PRESTRESSED, PRECAST CONCRETE BRIDGE GIRDERS: continued

3E-3 PERFORMANCE

A. FABRICATION:

1. Production procedures for the manufacture of precast, prestressed girders shall be in accordance with PCI, MNL-116-70.
2. Dimensional tolerance, shall conform to PCI, MNL-116-70.
3. Finish:
 - a. Precast units shall have straight, true edges and surfaces free from honeycomb or voids.
 - b. Top surface shall have wood-float finish.
 - c. Underside of members shall have smooth finish as derived from steel forms.

B. ERECTION:

1. Erect in accordance with the applicable provisions of PCI and AASHTO. Handle precast units in such manner to prevent excessive stresses or damage from chipping, cracking and etc.
2. Install members according to details on approved compliance submittals, in such manner that will prevent excessive bending about either axis.
3. Members shall be erected by experienced workmen and set in position within allowable tolerance by crane, lifting only at approved pick-up points.
4. Anchorage shall be as indicated. No drilled or explosive-driven inserts, anchors or drive-ins of any type shall be used in prestressed units.
5. Precast units that are damaged during erection such that their structural integrity is impaired will be rejected. Minor spalls shall be repaired subject to Engineer's approval.

* * * * *

DIVISION 4 - NOT USED

DIVISION 5 - METALS: STRUCTURAL AND MISCELLANEOUS

5A - STEEL

5A-1 GENERAL

A. DESCRIPTION:

1. This Section includes fabrication and erection of the following:
 - a. Structural steel as defined in AISC Manual, Code of Standard Practice.
 - b. Miscellaneous steel items as indicated.

B. QUALITY ASSURANCE:

1. Applicable Standards:
 - a. American Institute of Steel Construction (AISC):
 - (1) Manual of Steel Construction.
 - (2) Quality Criteria and Inspection Standards.
 - b. American Welding Society Structural Welding Code (AWS D1.1 Code).
 - c. American Society for Testing and Materials (ASTM):
 - (1) A6 - General Requirements for Delivery of Rolled Steel Plates, Shapes, Sheet Piling and Bars for Structural Use.
 - (2) A36 - Structural Steel.
 - (3) A53 - Welded and Seamless Steel Pipe.
 - (4) A106 - Seamless Carbon Steel Pipe for High Temperature Service.
 - (5) A108 - Cold-Finished Carbon Steel Bars and Shafting.
 - (6) A120 - Black and Hot-Dipped Zinc-Coated (Galvanized) Welded and Seamless Steel Pipe for Ordinary Uses.
 - (7) A123 - Zinc (Hot-Galvanized) Coatings on Products Fabricated from Rolled, Pressed, and Forged Steel Shapes, Plates, Bars and Strip.
 - (8) A153 - Zinc Coating (Hot Dip) on Iron and Steel Hardware.
 - (9) A264 - Stainless Chromium - Nickel Steel Clad Plate, Sheet and Strip.
 - (10) A307 - Low-Carbon Steel Externally and Internally Threaded Standard Fasteners.
 - (11) A325 - High-Strength Bolts for Structural Steel Joints, Including Suitable Nuts and Plain Hardened Washers.
 - d. Research Council on Riveted and Bolted Structural Joints of the Engineering Foundation "Specifications for Structural Joints Using ASTM A325 Bolts or A490 Bolts" as approved by AISC.
 - e. Steel Structures Painting Council (SSPC) - Steel Structures Painting Manual.
2. Acceptable Manufacturers: Specified in part 5A-2 and 5A-3.
3. Welder Qualifications:
 - a. Welders shall be previously qualified (within the past twelve months) by passing the tests prescribed in the AWS Standard Qualification Procedure, or by passing such other tests as the Engineer may accept.
 - b. Submit two certified copies of the qualification records to Engineer as evidence of qualification to the above-mentioned code.
4. Inspection: Material or workmanship will be subject to inspection in the shop and field.

5A - STEEL: continued

C. SUBMITTALS:

1. Compliance Submittals:
 - a. Submit as specified in DIVISION 1.
 - b. Includes, but not limited to, the following:
 - (1) Fabrication and erection drawings for all work.
 - (2) All necessary information for the fabrication, including filler metal for welds, of the component part of the structure, presented on drawings to conform to recognized standard practice, AISC Manual Part 5, and AWS Code.
 - (3) Drawings indicating stud shear connector spacing regardless of whether connectors are shop applied or field applied.
 - (4) Drawings showing each piece including anchor bolts marked for identification to correspond to erection drawings.
 - (5) Fabricator's drawings may include reproductions from Contract Drawings but responsibility for checking all dimensions shown remains with Contractor. Reproducibles of Contract Drawings will be furnished to Contractor as specified in DIVISION 1.
- D. DELIVERY, STORAGE AND HANDLING: Handle and store all steel and appurtenances as specified in DIVISION 1.

5A-2 MATERIALS

A. GENERAL:

1. Steel: Conform to ASTM A36, as designated in the AISC Manual, Part 1, unless otherwise indicated or specified.
2. Connection Bolts, Nuts and Washers: Conform to ASTM A325, unless otherwise indicated or specified.
3. Anchor Bolts:
 - a. Conform to ASTM A307 using A36 steel, unless otherwise indicated to be stainless steel or high strength.
 - b. Machine Bolts: Conform to ASTM A307.
4. Handrail: Conform to ASTM A53, Type E or S, Grade B; ASTM A106, Grade B; or ASTM A120 (with minimum yield strength of 33,000 psi).
5. Pipe for Structural Uses: Conform to ASTM A53, Type E or S, Grade B, or ASTM A106, Grade B.
6. Grating:
 - a. Main bars: Conform to ASTM A108, Grade 1015
 - b. Cross bars: Conform to ASTM A108, Grade 1010.
7. Welding:
 - a. Use E70 electrodes for shielded metal arc welding and E7 series electrodes for submerged arc.
 - b. Select filler metal as required by AISC Manual, Part 5, Section 1.17.
8. Galvanizing: Galvanize steel after fabrication to conform to ASTM A123 and ASTM A153, where indicated or specified.

B. STEEL FABRICATION:

1. Fabricate all steel to conform to AISC specifications, codes and standards.

5A - STEEL: continued

2. Permissible variations for sweep, camber, length and cross-section of all steel members shall conform to ASTM A6, AISC "Manual of Steel Construction, Part 1" and AISC "Quality Criteria and Inspection Standards" unless indicated otherwise.
3. Provide grout holes in baseplates having the least dimension greater than 24 inches.
4. Shop Milling:
 - a. Perform at the base of columns and at the top of column baseplates, except that rolled-steel bearing plates 4 inches thickness or less may be straightened by pressing.
 - b. Perform on butted ends for bolted column splices. Shop milling is not required for welded column splices with penetration welds.
 - c. Perform at ends of columns which butt against a plate.
5. Welding:
 - a. All welding shall be shielded metal arc or submerged arc.
 - b. Conform to AWS Code, AISC Manual Part 4 and the AISC Quality Criteria and Inspection Standards.
 - c. Inspection of welds will be in accordance with the AWS Code to determine the acceptability of welds. Correct defective welds.
6. Shop Connections:
 - a. Weld, rivet, or bolt at Contractor's option except when otherwise indicated or specified.
 - b. Shop portions of connections may be welded equivalent to any bolted connection specified if Engineer concurs.
 - c. Welded connections shall be as indicated or in accordance with acceptable alternative designs.
 - (1) Welds of connection angles to beam webs shall conform with AISC Manual Part 4, Tables III and IV with particular regard for minimum web thickness. Provide longer connection angles or reinforce web as required.
 - (2) All butt joint groove welds shall be complete penetration welds unless otherwise indicated and shall conform to the applicable standards in AISC Manual Part 4 with special emphasis on maintaining root opening. Accomplish this for single-bevel butt joint welds by using backup plates or by chipping out and welding on the opposite side.
 - (3) Prepare weld bevels with a mechanically guided cutting torch or by grinding.
 - (4) Remove all run-out tabs.
 - d. Bolted connections shall conform with AISC Manual Part 4.
 - (1) All bolted connections shall be made with 3/4-inch bolts, nuts and washers unless otherwise indicated or specified.
 - (2) Capacity of beam connections shall be equal to that specified in AISC Manual Part 4, Tables I and II for 3/4-inch ASTM A325 bolts in friction-type connections with the number of bolt rows indicated.
 - (3) Use no less than the minimum number of rows of bolts for a given beam size as required by Tables 1 and 2 of AISC Manual, Part 4.
7. Provisions for Field Connections:
 - a. Provide with bolted connections unless otherwise indicated or specified.

5A - STEEL: continued

- b. Provide for field welding only when so indicated or when detail clearances make bolting impractical.
 - c. Provide all members to be field welded with bolted erection connections adequate to resist erection stresses prior to field welding.
- C. COLUMN BASE AND EQUIPMENT ANCHOR BOLTS:
- 1. Furnish for all columns and equipment furnished and installed under this Contract, (and as required to install all equipment furnished by others for installation under this Contract unless otherwise indicated).
 - 2. Galvanize after fabrication where indicated.
- D. HANDRAIL:
- 1. 1½-inch nominal (1.9-inch outside diameter) round black standard-weight pipe.
 - 2. Post spacing shall not exceed 6 feet from center to center.
 - 3. Form and weld all handrail. Grind all welds smooth and even with the surface of the pipe, including field welds required for erection.
 - 4. Carefully form all handrail where change of direction or elevation occurs.
 - 5. Handrail posts shall be vertical (plumb) unless otherwise indicated.
- E. EDGE ANGLES AND PLATES:
- 1. Furnish around openings as indicated.
 - 2. Keep plates flush at intersections and fillet-weld to give a neat appearance at the exposed intersecting surfaces.
 - 3. Hot-dip galvanize after fabrication where indicated.
 - 4. Properly align, level and plumb before concrete is placed.
- F. KICK PLATES:
- 1. Furnish at the edge of uncovered openings and at the edge of walkways and platforms, except as otherwise indicated.
 - 2. Hot-dip galvanize after fabrication where indicated.
- G. STEEL FLOOR GRATING:
- 1. One-piece, resistance-welded steel construction without notching of bearing or cross bars before welding.
 - 2. Main Bars:
 - a. Thickness: 3/16-inch.
 - b. Depth: As indicated.
 - c. Spacing: Not more than 1-3/16 inches on centers.
 - d. Configuration of Top Surface of Main Bars: Plain unless otherwise indicated.
 - 3. Cross Bars:
 - a. Spacing: 4 inches on centers.
 - b. One of the following shapes:
 - (1) Hexagon with 5/16-inch diameter of inscribed circle.
 - (2) Rectangular 1/2-inch x 3/16-inch.
 - (3) Square 1/4-inch with spiral twist.
 - (4) Round 21/64-inch diameter.

5A - STEEL: continued

4. Fabrication:

- a. Main bars shall be vertical within a tolerance of 0.10-inch per inch of depth.
- b. Longitudinal bow (before fastening to supports) shall be less than 1/200 of the length.
- c. Transverse bow before fastening to supports shall be less than 3/8-inch in 3 feet.
- d. Crossbars shall not deviate from a straight line perpendicular to the main bars by more than 3/16-inch in 3 feet.
- e. Crossbars shall match crossbars of adjacent sections to form a continuous pattern of straight lines.
- f. Panel width and length tolerances shall be $\pm\frac{1}{4}$ inch.
- g. Provide all openings in grating indicated and as required for installation of all piping, wiring and equipment installed under this Contract.
- h. Band all openings 4 inches and larger with a metal bar same size as main bearing bar. Weld to each bearing bar with a 3/16-inch fillet weld 3/4-inch long. Tack weld to all crossbars.
- i. Trim-band all locations as follows:
 - (1) Open end of grating at head of a ladder.
 - (2) Manway opening.
 - (3) Hinged sections.
 - (4) Grating panels with four crossbars or less.
 - (5) Other locations as indicated.

5. Shop Finish:

- a. Paint with manufacturer's standard black paint by spray, dipping, or flow coating unless otherwise indicated.
 - b. Galvanize where indicated.
6. Manufacturer: Grating shall be manufactured by one of the following:
- a. Blaw Knox, Pittsburgh, Pennsylvania.
 - b. Dravo Corporation, Pittsburgh, Pennsylvania.
 - c. IKG Industries.
 - d. Klemp Corporation, Chicago, Illinois.
 - e. Borden Metal Products Company, Elizabeth, New Jersey.

H. CONCRETE AND MASONRY ANCHORS:

1. Manually expanded anchor type.
2. Furnish sizes indicated and install to conform to manufacturer's printed instructions.
3. Anchors shall be manufactured by one of the following:
 - a. Phillips Drill Company, Inc., Michigan City, Indiana.
 - b. Star Expansion Industries Corporation, Mountainville, New York.
 - c. U.S. Expansion Bolt Company, York, Pennsylvania.

5A-3 PERFORMANCE

A. PREPARATION:

1. Field-check location and elevation of column anchor bolts and footings before erecting structural steel columns.
2. Contractor shall submit the method and sequence of erection for acceptance.

5A - STEEL: continued

B. STEEL ERECTION:

1. Erect all steel to conform to AISC specifications, codes and standards, AISC Quality Criteria and Inspection Standard or any local, State or Federal Codes which may exceed such requirements.
2. Protect steel from entrapped water that can cause damage from freezing or corrosion.
3. Column Baseplates:
 - a. Grout under baseplates with a flowable nonshrink grout, taking special care not to disturb their grade and alignment.
 - b. Flowable non-shrink grout shall be one of the following:
 - (1) Masterflow 713 grout, Master Builders Company, Cleveland, Ohio.
 - (2) Saurereisen F100, Saurereisen Cement Company, Pittsburgh, Pennsylvania.
 - (3) Five Star Grout, U. S. Grout Corporation, Old Greenwich, Connecticut.
 - c. Cut off exposed edges of the grout at 45 degrees along the edges of the baseplates after grout has acquired its initial set.
4. Erection Bracing:
 - a. Provide all necessary temporary struts, ties, cables, temporary flooring, planking and scaffolding in connection with the erection of the structural steel or support of erection machinery.
 - b. Place as required to maintain proper position against loads from erection equipment, construction material and wind.
 - c. Leave bracing in place until sufficient steel connections, concrete slabs, exterior walls, and roof decks are in place to insure stability of the structure.
5. Connections:
 - a. Unless otherwise indicated, or clearance is insufficient, connections shall be bolted friction type.
 - b. Tighten high-strength bolts to correct bolt tension in accordance with AISC Manual, Part 5, "Specification for Structural Joints using A325 or A490 Bolts."
 - c. Furnish the inspecting wrench and one man to assist the Engineer when inspections are performed.
 - d. Provide Skidmore-Wilhelm Bolt-Tension calibrator or approved equal for adjusting inspection wrench and/or calibrated wrench in accordance with AISC Manual, Part 5.
 - e. Load Indicators:
 - (1) The use of load indicators is an acceptable alternative to the requirements of paragraph 6.c. and 6.d. above in determining specified minimum bolt tension.
 - (2) Use Coronet Load Indicators as manufactured by Cooper and Turner, Inc., East Hartford, Connecticut, or an approved equal.
 - (3) Install in accordance with manufacturer's written instructions.
 - f. Welded Connections:
 - (1) Make welded connections as indicated and leave all erection bolts in place after completion of welding unless otherwise indicated.
 - (2) Reinforce connections when members requiring fillet welds are not in contact.
 - (3) Use backup bars or spacer bars on all butt welds where root opening exceeds 3/16-inch.
 - (4) Remove all run-out tabs.

5A - STEEL: continued

6. Welding and Welders:
 - a. The requirements for erection welding and welders shall be the same as specified for steel fabrication.
 - b. All welds shall be stamped with a mark identifying the welder. Remove welders from work after two defective welds.
7. Protect pipe sleeves, other anchorage members and concrete bases from deleterious materials at all times, and from water which may cause ice damage during freezing weather.
8. Handrail:
 - a. Form and weld all handrail. Grind all welds smooth and even with the surface of the pipe.
 - b. Carefully fit all handrail where change of direction or elevation occurs.
 - c. Install all rails and posts plumb, level, straight and true and in alignment.
 - d. Top rail shall clear all fixed objects by at least 3 inches vertically and horizontally.
 - e. Furnish and install plates, bolts, and additional items as indicated or required for fastening to supporting members.
9. Grating:
 - a. Space fasteners as required to overcome irregularities and maintain grating contact with supports. Minimum anchorage of each panel will be two fasteners at each end and one fastener at each intermediate support.
 - b. Where indicated as fixed, and if not galvanized, fasteners shall be 3/16-inch fillet welds 3/4-inch long.
 - c. Unless indicated as fixed, or if galvanized, fasten with galvanized clips using welding studs.
 - d. All grating shall be removable unless otherwise indicated.

* * * * *

DIVISION 6 - NOT USED

DIVISION 7 - NOT USED

DIVISION 8 - NOT USED

DIVISION 9 - NOT USED

DIVISION 10 - NOT USED

DIVISION 11 - NOT USED

DIVISION 12 - NOT USED

DIVISION 13 - NOT USED

DIVISION 14 - NOT USED

DIVISION 15 - NOT USED

DIVISION 16 - NOT USED

DIVISION 17 - YARD PIPING

17A - GENERAL REQUIREMENTS

17A-1 GENERAL

A. DESCRIPTION:

1. This Division includes furnishing all material, equipment, and labor for the complete installation of all yard piping, including the following:
 - a. Wall Piping for Cooling Tower Basin.
 - b. Sanitary Sewer Systems and Storage Pond Overflow Systems.
 - c. Potable Water Piping for Guard House.

B. QUALITY ASSURANCE:

1. Applicable Standards: As specified in each applicable SECTION.
2. Acceptable Manufacturers: As specified in each applicable SECTION.

17A-2 EQUIPMENT AND MATERIALS

- A. PIPING AND OTHER MATERIAL: As indicated and as specified in each applicable SECTION.

17A-3 PERFORMANCE

A. FIELD MEASUREMENTS:

1. Make all field measurements necessary to determine line and grade and insure installation of all piping as indicated.
2. Perform all required field or shop cutting and fitting.

- B. INSTALLATION: As specified in SECTION 17E.

- C. CONNECTIONS: Install all manholes, and other accessories as indicated and as specified.

* * * * *

17B WALL PIPING FOR COOLING TOWER BASIN

17B-1 GENERAL

A. DESCRIPTION:

1. This Section includes piping to be cast in the walls of the cooling tower basin.

B. QUALITY ASSURANCE:

1. Applicable Standards:
 - a. American Society for Testing and Materials (ASTM):
 - (1) A139 - Electric-Fusion (ARC)-Welded Steel Pipe.
 - (2) A283 - Low and Intermediate Tensile Strength Carbon Steel Plates of Structural Quality.
 - b. American Water Works Association (AWWA):
 - (1) C200 - Steel Water Pipe 6 Inches and Larger.
 - c. Steel Structures Painting Council (SSPC).
2. Acceptable Manufacturers: As specified in Part 17B-2.

C. SUBMITTALS:

1. Compliance Submittals:
 - a. Submit as specified in DIVISION 1.
 - b. Include, but not limited to the following:
 - (1) Specifications.
 - (2) Complete details of pipe.
 - (3) Wall thickness of pipe.
 - (4) Ultimate strength, elastic limit, and modulus of elasticity of steel.
 - (5) Bills of Materials.

17B-2 EQUIPMENT AND MATERIALS

A. STEEL PIPE:

1. Manufacture in accordance with AWWA C200 using material conforming to ASTM A283, Grade C, or using material conforming to ASTM A139, Grade A or B.
2. Manufacturer shall be experienced in the design and fabrication of large diameter steel pipe.
3. Pipe inside diameter: 48 inches.
4. Pipe wall thickness: 3/8-inch.
5. Shop Tests:
 - a. Conduct all tests standard with the manufacturers and as specified.
 - b. Hydrostatic Test: Each section of pipe shall be hydrostatically tested in accordance with the applicable codes and standards. In lieu of hydrostatic testing, the Contractor may, at his option, conduct nondestructive tests such as radiographic examination, dye penetrant; or magnafluxing to check weld integrity. Test shall be conducted prior to application of protective coating.
 - c. Submit copies of reports to the Engineer for all shop tests conducted.
6. Protective Shop Coating: Apply a shop prime coat of Koppers P-1500 Inorganic Zinc No. 3 to the exterior and interior surfaces of steel pipe. Prior to application of coating, pipe shall be blasted to a minimum of SSPC-SP-10 (Near-White Blast Cleaning). Apply coating in strict accordance with manufacturer's recommendations maintaining a

17B WALL PIPING FOR COOLING TOWER BASIN: continued

minimum dry thickness of 2 mils. Apply coating to within six inches of pipe ends.

7. Ship steel wall pipes to field with temporary spiders in each piece and strutted to maintain 48-inch vertical and horizontal inside diameters.
8. Protective Field Coating: Apply one coat of Koppers P-1500 Inorganic Zinc No. 3 to all damaged surfaces of coating after pipe is installed.

B. ABS COUPLING:

1. Conform to requirements of SECTION 17C - SANITARY SEWER SYSTEMS AND STORAGE POND OVERFLOW SYSTEMS for ABS PIPE.
2. To be used only where indicated.

C. DUCTILE IRON WALL PIPE: Conform to requirements of SECTION 17C - SANITARY SEWER SYSTEMS AND STORAGE POND OVERFLOW SYSTEMS for DUCTILE IRON PIPE.

17B-3 PERFORMANCE

- A. INSTALLATION: All pipe is to be cast in place as indicated and as specified in Section 17E.

* * * * *

17C SANITARY SEWER SYSTEMS AND STORAGE POND OVERFLOW SYSTEMS

17C-1 GENERAL

A. DESCRIPTION:

1. This Section includes piping and accessories for the Sanitary Sewer Systems and the Storage Pond Overflow Systems.
2. Related Work Specified Elsewhere:
 - a. Pipe Installation: SECTION 17E.
 - b. Field Testing: SECTION 17F.

B. QUALITY ASSURANCE:

1. Applicable Standards:
 - a. American National Standards Institute (ANSI):
 - (1) A21.4 - Cement Mortar Lining for Cast-Iron Pipe and Fittings for Water.
 - (2) A21.10 - Gray-Iron and Ductile-Iron Fittings, 2-Inch Through 48-Inch, for Water and Other Liquids.
 - (3) A21.11 - Rubber Gasket Joints for Cast-Iron and Ductile-Iron Pressure Pipe and Fittings.
 - (4) A21.15 - Flanged Cast-Iron and Ductile-Iron Pipe with Threaded Flanges.
 - (5) A21.51 - Ductile Iron Pipe, Centrifugally Cast, in Metal Molds or Sand-Lined Molds for Water or Other Liquids.
 - b. American Society for Testing and Materials (ASTM):
 - (1) C32 - Sewer and Manhole Brick (Made from clay or shale).
 - (2) C270 - Mortar for Unit Masonry.
 - (3) C443 - Joints for Circular Concrete Sewer and Culvert Pipe, Using Rubber Gaskets.
 - (4) C478 - Precast Reinforced Concrete Manhole Sections.
 - (5) D2680 - Acrylonitrile-Butadiene-Styrene (ABS) Composite Sewer Piping.
 - (6) D2751 - Acrylonitrile-Butadiene-Styrene (ABS) Sewer Pipe and Fittings.

C. SUBMITTALS:

1. Compliance Submittals:
 - a. Submit as specified in DIVISION 1.
 - b. Include, but not limited to, the following:
 - (1) Layout drawings.
 - (2) Specifications.
 - (3) Complete details of pipe, fittings and specials.
 - (4) Bills of Materials.
2. Test Reports: Submit as specified in PART 17C-2.

D. DELIVERY AND HANDLING: As specified in PART 17C-2.

17C-2 EQUIPMENT AND MATERIALS

- A. GENERAL REQUIREMENTS: Furnish pipe of materials, joint types, sizes, and strength classes indicated or specified. Higher strengths may be furnished at Contractor's option.
- B. Pipe for relocation of existing sanitary sewer system and 6-inch SD4 shall be ABS pipe as specified herein.

17C - SANITARY SEWER SYSTEMS AND STORAGE POND OVERFLOW SYSTEMS: continued

C. ABS PIPE:

1. Pipe with diameter 8 inches and larger shall be composite pipe conforming to ASTM D2680 as specified and modified herein.
2. Pipe with diameter smaller than 8 inches shall conform to ASTM D2751, and wall thickness class shall be SDR 23.5.
3. Joints:
 - a. Type OR at walls.
 - b. Type SC (elsewhere).
4. Design and Manufacturer: Factory attach joint elements to pipe.
5. Inspection and Testing:
 - a. Primarily by manufacturer's quality control personnel.
 - b. Perform to avoid, insofar as possible, delivery of defective pipe.
 - c. May be witnessed by Owner, Engineer, or approved independent testing laboratory.
 - (1) Independent testing laboratory, when utilized, shall be retained by Owner at no expense to Contractor.
 - (2) Contractor and manufacturer shall cooperate with Owner's inspection and test personnel. Permit unrestricted access, furnish reasonable space and facilities, and provide adequate advance notice of test schedule.
 - d. Contractor shall provide 3 copies each of certified test reports to Engineer.
 - (1) Include stiffness and deflection, stiffness and deflection after acid conditioning, dimension, and hydrostatic joint tests.
 - (2) Furnish prior to delivery.
6. Handling and Delivery:
 - a. Do not deliver until tests on representative specimens have been performed.
 - b. Use equipment and methods adequate to preserve quality of pipe and to protect joint elements.

D. CORRUGATED METAL PIPE:

1. Shall conform to requirements of SECTION 2B for CORRUGATED METAL PIPE.
2. To be used only where indicated.

E. DUCTILE-IRON PIPE:

1. General:
 - a. Pipe: Conform to ANSI A21.51 or ANSI A21.15 for flanged pipe.
 - b. Minimum thickness class specified based on 60-42-10 grade iron.
 - c. To be used only where indicated.
2. Joints:
 - a. Mechanical or push-on-type joints conforming to ANSI A21.11 for all buried pipe unless otherwise specified or indicated.
 - b. Flanged joints for all interior and exposed exterior pipe except where otherwise specified or indicated.
3. Fittings:
 - a. Conform to ANSI A21.10 with pressure rating as specified.
 - b. Fittings shall be ductile-iron or gray iron at manufacturer's option.
 - c. Fittings for pipe with mechanical joint shall have mechanical joints.

17C - SANITARY SEWER SYSTEMS AND STORAGE POND OVERFLOW SYSTEMS: continued

- d. Fittings for pipe with push-on joints shall be mechanical joint or push-on-type joint.
- e. Include all specials, taps, plugs, flanges, adapters and wall fittings as required and as indicated.
- 4. Lining: Line all pipe, fittings and specials with cement-mortar to conform to ANSI A21.4.
- 5. Coating: Coat all pipe, fittings and specials with manufacturer's standard coating.

<u>Pipe Diameter</u>	<u>PIPING TABLE</u> <u>Pipe Class</u>	<u>Fitting Class</u>
24-inch	50	150

F. MANHOLES:

- 1. Manhole materials shall conform to requirements of DIVISION 3 - Concrete, except as follows:
 - a. Mortar: Conform to ASTM C270, Type M.
 - b. Sewer Brick: Conform to ASTM C32, Grade SM.
- 2. Precast Concrete Manholes: Precast units shall meet the following requirements:
 - a. Equal or exceed provisions of ASTM C478. Manhole design and construction shall be approved in writing by the Engineer.
 - b. Include risers, cone, cover and frame, and steps. Base shall be cast-in-place concrete in conformance with DIVISION 3 - CONCRETE.
 - c. Rubber gaskets shall be of the O-ring type.
 - d. Join manhole sections with rubber and concrete joints conforming with ASTM C443.
 - e. Install manhole steps at 16 inches on center vertical.
- 3. Manhole Covers and Frames: As indicated on the drawings.
- 4. Manhole Steps: No. 3232 as manufactured by Clay & Bailey or approved equal.
- 5. Apply two coats of Koppers Bitumastic No. 50 to the exterior surface.

G. SLIDE GATES:

- 1. Slide gates shall be Armco Model 5-00 Fabricated Steel Slide Gates or approved equal. Slide gates shall be of the flat-back style.
- 2. All steel parts shall be galvanized.
- 3. Shall have handwheel operators.

H. FLY ASH POND OVERFLOW MEASUREMENT:

- 1. Furnish and install Kennison Nozzle, instruments, and all accessories, indicated or required, for measuring and recording Fly Ash Pond Overflow #1.
- 2. Kennison Nozzle:
 - a. Kennison Nozzle shall be a BIF Product Series 135 Kennison Open Flow Nozzle or approved equal.
 - b. Design Data:
 - (1) Line Size: 24-inch.
 - (2) Operating Range: 0.5 cfs to 10 cfs.
 - c. Shall include a manual vent cleaner installed on the left side of the nozzle looking downstream.
 - d. The inlet end shall be flanged with ANSI 125 pound standard drilling.

17C - SANITARY SEWER SYSTEMS AND STORAGE POND OVERFLOW SYSTEMS: continued

- e. The nozzle shall be installed level in both lengthwise and crosswise directions.
- f. Shall include a BIF model STKN sediment tank.
- 3. Furnish, install and calibrate one (1) Foxboro Co. 3100 Series float and cable instrument for monitoring fly ash pond overflow with the following specifications:
 - a. Model No. 3183.
 - b. Float Travel: 24-inches.
 - c. Installation: Kennison Open Flow Nozzle
 - d. Cable: 25-foot nylon coated AISI Type 304 Stainless Steel.
 - e. Type of cam: Linear.
 - f. Scale Range: 0-6.5 MGD.
 - g. Optional Features:
 - (1) Provide a 24E Integrator with a linear cam and relay output for a remote counter furnished by others.
 - (a) Supply voltage shall be 120V, 60 Hz.
 - (2) Provide two (2) Type 70 contacts for alarm - High flow and Low flow.
 - (3) Provide an 8-9inch diameter AISI Type 304 Stainless Steel float.
 - h. Tag: OAHF/FR-1.

17C-3 PERFORMANCE

- A. INSTALLATION: As specified in DIVISION 17E.

* * * * *

17D - POTABLE WATER

17D-1 GENERAL

A. DESCRIPTION:

1. This Section includes piping and accessories for the potable water for the Guard House.
2. Related Work Specified Elsewhere:
 - a. Pipe Installation: SECTION 17E.
 - b. Field Testing: SECTION 17F.

B. QUALITY ASSURANCE:

1. Applicable Standards:
 - a. American National Standards Institute (ANSI):
 - (1) B16.3 - Malleable-Iron Screwed Fittings, 150 and 300 pound.
 - (2) B16.5 - Steel Pipe Flanges and Flanged Fittings.
 - (3) B16.21 - Nonmetallic Gaskets for Pipe Flanges.
 - b. American Society for Testing and Materials (ASTM):
 - (1) A47 - Malleable Iron Castings.
 - (2) A53 - Welded and Seamless Steel Pipe
 - (3) A120 - Black and Hot Dipped Zinc-Coated (Galvanized) Welded, and Seamless Steel Pipe for Ordinary Uses.
 - (4) A307 - Carbon Steel Externally and Internally Threaded Standard Fasteners.
 - c. American Water Works Association (AWWA):
 - (1) C500 - Gate Valves - 3 Inches Through 48 Inches, for Water and Other Liquids.
 - (2) M11 - Design and Installation of Steel Pipe.
2. Acceptable Manufacturers: As specified in PART 17D-2.

C. SUBMITTALS:

1. Compliance Submittals:
 - a. Submit as specified in DIVISION 1.
 - b. Include, but not limited to the following:
 - (1) Layout drawings.
 - (2) Specifications.
 - (3) Complete details of pipe, fittings and specials.
 - (4) Bills of Materials.

17D-2 EQUIPMENT AND MATERIALS

A. STEEL PIPE:

1. General:
 - a. Pipe: Conform to ASTM A120 or A53.
 - b. Wall thickness class - Schedule 80.
 - c. Size - 2-inch.
2. Joints:
 - a. Threaded joints for 2-inch pipe.
 - b. Flanges where specified or indicated shall conform to applicable provisions of ANSI B16.5 - Class 150.
3. Fittings and Specials:
 - a. Threaded fittings and unions: 300-pound malleable iron conforming to ASTM A47 and ANSI B16.3.
 - b. Include all adapters, outlets, taps, plugs, and other specials as required to complete installation as specified or indicated.

17D - POTABLE WATER: continued

4. Coating:

- a. Hot-dip galvanize all pipe inside and outside as specified in ASTM A53 or A120.

B. GATE VALVE:

1. General:

- a. Valve shall be buried and located on the potable water line to the Guard House.
- b. Valve shall be a 2-inch, horizontal, NRS (Nonrising Stem Seal) type with flanged ends and AWWA operator type nut.
- c. Valve shall be delivered to the plant site with tag identifying it as Valve No. PW8-1.

2. Acceptable Manufacturers:

- a. American-Darling Division, American Cast Iron Pipe Company.
- b. Clow Corporation.
- c. Kennedy Valve Manufacturing Company, Inc.
- d. Ludlow-Rensselaer Valve Company.
- e. M & H Valves, Dresser Industries, Inc.
- f. Mueller Company.

3. Design:

- a. Conform to AWWA C500 and as specified.
- b. Double-disc type.
- c. Nonrising stem seals shall be double O-ring type.

4. Operators:

- a. All valves shall open counterclockwise.

5. Testing:

- a. Testing shall be performed conforming to AWWA C500.
- b. Furnish affidavit of compliance.

6. Shop Painting:

- a. Prepare surfaces and paint or coat all valves, valve boxes and all related accessories standard of the manufacturer.
- b. Paint and coatings shall be suitable for the service intended.
- c. Submit type of paint or coating proposed with drawings and data prior to fabrication.

C. VALVE BOXES:

1. Acceptable Manufacturers:

- a. Clay and Bailey.
- b. Clow Corporation.
- c. Mueller Company.
- d. Tyler Company.

2. Provide for all buried valves.

3. Design:

- a. Boxes shall be three-piece screw type with 5½-inch shaft.
- b. Provide extension stem to bring operating nut within 2 feet of valve box top.
- c. Drop cover shall be marked "water."

17D - POTABLE WATER: continued

D. GASKETS AND BOLTING MATERIALS:

1. Provide all gaskets, bolts, lubricant, and other accessories required to install pipe, fittings and specials complete and ready for service.
2. Gaskets for Flanged Joints: Conform to ANSI B16.21, 1/8-inch thick full face red rubber.
3. Bolts for Flanged Joints: Conform to ASTM A307, Grade B. Nut and bolt heads shall be hexagonal.

17D-3 PERFORMANCE

- A. INSTALLATION: Conform to AWWA M11 for steel pipe, and SECTION 17E.

* * * * *

17E - PIPE INSTALLATION

17E-1 GENERAL

A. DESCRIPTION:

1. This Section includes the installation of piping and accessories specified in this Division.
2. Related Work Specified Elsewhere.
 - a. Site Work: DIVISION 2.

B. QUALITY ASSURANCE:

1. Applicable Standards:
 - a. American Water Works Association (AWWA):
 - (1) C600 - Installation of Gray and Ductile Cast Iron Water Mains and Appurtenances.
 - (2) C601 - Disinfecting Water Mains.
 - (3) M11 - Design and Installation of Steel Pipe.

C. HANDLING:

1. Handle pipe in a manner to insure installation in sound, undamaged condition using proper equipment, tools, and methods as follows:
 - a. Suitable slings or skids.
 - b. Without hooks in contact with joint surfaces.
 - c. Provisions for preventing contact with adjacent units during moving or storage.
 - d. Protection for all pipe ends such as beveled ends, flanges, mechanical joints, plain ends, threads, etc., prior to shipping to jobsite.
2. Pipe damaged during transporting or handling which, in the opinion of the Engineer, cannot be satisfactorily repaired will be rejected.

17E-2 EQUIPMENT AND MATERIALS

- A. EQUIPMENT AND MATERIALS: As specified in each applicable Section.

17E-3 PERFORMANCE

A. PIPE INSPECTION AND REPAIR:

1. All pipe shall be subject to the approval of the Engineer.
2. Repair all concrete or mortar coatings with an epoxy grout applied as recommended by the manufacturer. Prepare cracks in lining by routing or grooving an opening 7/8 of the lining thickness in depth and a minimum of 1/2-inch wide at the surface.
3. Pipe sections damaged by handling which, in the opinion of the Engineer, cannot be satisfactorily repaired shall be rejected.

B. CLEANING:

1. Thoroughly clean interior of all pipe, fittings, and joints before installation.
2. Exclude foreign matter during discontinuances of installation as follows:
 - a. Close ends with snug-fitting board containing several small holes near the center.
 - b. Prevent water from filling trench.
 - c. Remove all water, mud, sand, and other undesirable materials from trench prior to removal of end board.

17E - PIPE INSTALLATION: continued

3. Do not place tools, clothing, or other materials at any time in pipe.
4. Check air in pipe for gas after prolonged periods of enclosure, and replace with fresh air before resuming construction.
5. Visually inspect, remove all struts, and sweep clean or flush clean immediately prior to final fitting of system.

C. LAYING:

1. Lay pipe according to the plans and laying schedule prepared by pipe manufacturer and as follows:
 - a. Lay pipe such that fittings and other appurtenances are at the required locations.
 - b. Construct field connections true to line, facing, and position without undue strain on the pipe, fittings, and equipment.
 - c. Do not permit laying of pipe in water or on blocks except when encasement is to be provided.
 - d. Brace or anchor as required to prevent displacement of pipe during embedment or encasement operations.
 - e. Perform only when weather and trench conditions are suitable.
 - f. Install ductile-iron pipe conforming to AWWA C600.
 - g. Install ABS pipe conforming to manufacturer's recommendations.
 - h. Conform to lines, grades and elevations as indicated.
 - i. Maintain alignment and grade with batter boards at intervals as necessary but not to exceed 50 feet.
 - j. Install steel pipe conforming to AWWA M11.

D. PROTECTIVE FIELD COATINGS:

1. Ductile-Iron Pipe: Coat all joints with two coats of Koppers Bitumastic 505.
2. Steel Pipe: Coat all buried flanged joints and tapping saddle with Koppers Bitumastic 505.

E. EXCAVATION, TRENCHING, BEDDING AND BACKFILLING: Conform to DIVISION 2 and as follows:

1. Excavate to provide alignment and depth as indicated.
2. Remove rock and other obstructions to provide clearance of trench width and depth as specified.
3. Utilize sheeting as required to insure that trench width does not exceed maximum width specified for type of pipe being installed.
4. Overexcavate and backfill to foundation grade with approved compacted material as directed by the Engineer, if necessary to assure firm pipe foundation.
5. Adequately drain trenches during installation and maintain in dewatered condition throughout installation, bedding, and backfill operations except for subaqueous installations.
6. Provide with bell holes where required for joints.
7. Backfill only with material approved by the Engineer. Backfill and compact by hand in 6-inch layers to a point one foot above the top of pipe.
8. Place remainder of backfill and compact as specified in DIVISION 2.
9. Do not remove sheeting until pipe is laid, tested, repaired, if necessary, and backfill is compacted 2 feet above the top of the pipe.

17E - PIPE INSTALLATION: continued

F. RELOCATION OF EXISTING SANITARY SEWER SYSTEM:

1. Relocation of the existing sanitary sewer system shall be done in conformance with DIVISION 1 - GENERAL REQUIREMENTS, as specified herein, and as indicated.
2. At no time shall service of the sanitary sewer system be interrupted.
3. The Contractor shall completely install the three new manholes over the existing sanitary sewers while the existing sanitary sewers are in service.
4. The portion of the existing sanitary sewer system which is to be abandoned shall not be taken out of service until the new sanitary sewers have been completely installed and put in service.

G. INSTALLATION OF POTABLE WATER PIPING FOR GUARD HOUSE:

1. Contractor shall coordinate connection to existing potable water system with Engineer and Owner.
2. Contractor shall perform connection to existing potable water system so as to minimize as much as possible the interruption of service of the system.
3. Disinfection of Pipelines for Conveying Potable Water:
 - a. Contractor shall provide all equipment and materials and perform conforming to AWWA C601.
 - (1) As modified herein.
 - (2) Include chlorination and final flushing.
 - b. Obtain approval of materials and acceptance of methods proposed for use.
 - c. May be conducted in conjunction with acceptance tests.
 - d. Owner will provide sampling and laboratory testing.
 - e. Dispose of flushing water without damage to public or private property.
 - f. Repeat disinfection procedure should initial treatment fail to yield satisfactory results.
 - (1) At no additional cost to Owner.
 - (2) Owner will provide water under terms stipulated for acceptance tests.

* * * * *

17F - FIELD TESTING

17F-1 GENERAL

A. DESCRIPTION:

1. This section includes requirements for hydrostatic testing of the systems.

17F-2 EQUIPMENT AND MATERIALS

A. GENERAL:

1. All equipment and materials used to perform the tests shall be subject to the approval of the Engineer.
2. Furnish all required materials and equipment for the testing to include, but not limited to, the following:
 - a. Necessary piping connections.
 - b. Test pumping equipment.
 - c. Water meter.
 - d. Pressure gauge.
 - e. Bulkheads, supports, struts, strong backs, etc.
 - f. All miscellaneous items required.

- B. WATER: Contractor shall be responsible for obtaining water for performing tests.

17F-3 PERFORMANCE

A. GENERAL:

1. All test methods shall be subject to the approval of the Engineer.
2. All tests shall be performed by the Contractor.
3. Protect all plant equipment and material from damage resulting from leakage during the tests, and repair or replace if damaged.
4. Do not proceed with test without approval of Engineer.

B. SPECIAL REQUIREMENTS:

1. Bulkhead and support piping during hydrostatic testing to prevent any damage to pipe or structures. Damage resulting from inadequate bulkhead or supports shall be repaired by the Contractor at his expense.
2. Fill pipeline, with adequate venting facilities installed and open, at a rate not exceeding the venting capacity.

C. HYDROSTATIC TESTING:

1. Apply after the pipeline has been completely filled with water.
2. Apply in such a manner that the required pressure can be obtained and maintained for the duration of the tests.
3. Measure at the low point in the system with a tested, properly calibrated, and approved pressure gauge and in accordance with the following table:

17F - FIELD TESTING: continued

<u>System</u>	Test	Duration of	<u>Leakage</u>
	<u>Pressure (psig)</u>	<u>Test</u>	
Sanitary Sewer	5	2 Hrs	0
Potable Water	Main Line Pressure	2 Hrs	0

D. AIR TESTS:

1. At the Contractor's option, the sanitary sewer systems may be air tested in lieu of hydrostatic tested.
 - a. Equipment and methods used to perform the tests shall be subject to approval of the Engineer.
 - b. Plug ends of pipe system and cap or plug all connections to withstand internal test pressures.
 - c. Introduce compressed air until internal air pressure is 4.0 psi greater than the average back pressure of ground water above the pipe.
 - d. Allow two minutes for air pressure to stabilize.
 - e. Time required for pressure to decrease from 3.5 to 2.5 psig greater than the average back pressure of any ground water above the pipe shall not be less than the time in the following table for the given diameters:

<u>Pipe Diameter</u> <u>(inches)</u>	<u>Minutes</u>
4	2.0
6	3.0
8	4.0
15	7.5

- E. REPAIRS: If the tests discloses leakage greater than that specified, the Contractor shall, at his expense:
1. Locate and repair the defective pipe, joint, or joints.
 2. Repeat the above tests until the leakage is within the specified allowance.

* * * * *

Phelps, Hogland & Phillips

Engineering
Company

12401 East 43rd. Street Independence, Missouri 64055
Tel: 816-373-9450

Burns & McDonnell

Engineers
Architects
Consultants

4600 East 63rd. Street Kansas City, Missouri 64141
Tel: 816-333-4375 Twx: 910-771-3059

Reply to: P. O. Box 173, Kansas City, Missouri 64141

November 14, 1978

Mr. Leroy Brown
Potashnik Construction, Inc.
P. O. Box 190
Cape Girardeau MO 63701

Re: Board of Municipal Utilities
Sikeston Power Station - Unit 1
Project 76-076-1
Contract 33 - Site Preparation II
‣ Request for Change Order Proposal (C03)

Dear Mr. Brown:

We request a proposal from you for adding, by change order to Contract 33 - Site Preparation II, the installation of steel pipe for two 48-inch diameter circulating water pipelines. The two pipelines, one 534 feet long and the other 50 feet long, are to be installed in the cooling tower basin as indicated on the enclosed drawing. The pipe material will be furnished by others, and delivered to the job site by February 15, 1979. Upon delivery at the site, the pipe would be received and unloaded by Potashnik. Pipe supports as indicated would be furnished and installed by Potashnik.

This change order to Contract 33 - Site Preparation II would require the following changes:

Specifications: Add the following section to DIVISION 17 -
Yard Piping:

DIVISION 17G - CIRCULATING WATER PIPE

17G-1 GENERAL:

A. DESCRIPTION:

1. This Division includes the unloading, installation, and field testing of piping and accessories for the Circulating Water system as indicated and as specified.

17G-1

RECEIVED

NOV 16 1978

SIKESTON
LIGHT & WATER

17G-1 GENERAL: continued

2. Equipment and materials furnished by others are as specified in this Division. The Contractor shall furnish all labor and all other equipment and materials needed for the complete installation of the Circulating Water system as indicated and as specified herein.

B. QUALITY ASSURANCE:

1. Applicable Standards:

- a. American Society for Testing and Materials (ASTM):
 - (1) A283 - Low and Intermediate Tensile Strength Carbon Steel Plates of Structural Quality.
- b. American Water Works Association (AWWA):
 - (1) C200 - Steel Water Pipe 6 Inches and Larger.
 - (2) C206 - Field Welding of Steel Water Pipe Joints.
 - (3) M11 - Design and Installation of Steel Pipe.
- c. American Welding Society (AWS).
- d. Steel Structures Painting Council (SSPC).

2. Qualification of Welders:

- a. Welding operators shall be qualified in accordance with AWS "Standard Qualification Procedure."
- b. Qualification tests shall be certified by the Contractor.
- c. All costs incident to qualification tests shall be paid by the Contractor.

C. SUBMITTALS:

1. Compliance Submittals:

- a. Submit as specified in DIVISION 1.
- b. Include, but not limited to, the following:
 - (1) Specification and Bill of Material for materials furnished by Contractor.
 - (2) Installation schedule.
 - (3) Complete details of pipe supports furnished by Contractor.

- D. Pipe manufacturer's layout drawings will be provided to the Contractor.

17G-2 PIPE MATERIAL

- A. PIPE MATERIAL FURNISHED BY OTHERS: Pipe materials furnished by others for the Circulating Water system is as shown on the drawings and will be as follows:

1. Pipe furnished will be manufactured in accordance with AWWA C200 using material conforming to ASTM A283, Grade B.
2. Pipe inside diameter is 48 inches. Pipe wall thickness is 3/8-inch.
3. Ends of pipe sections will be prepared for the following field weld joints:

17G-2 PIPE MATERIAL: continued

<u>Type of Weld</u>	<u>Number of Welds</u>
Lap Joint Field Weld	Twelve (12)
Butt Weld	Two (2)

4. Interior and exterior surfaces of the pipe will be coated with two (2) coats of Kopper's Bitumastic No. 300-M coal tar epoxy. Coatings will be applied to within six inches of pipe ends which will be field welded.
5. Delivery of pipe material furnished by others to the plant site is scheduled for February 15, 1979.

B. MATERIALS FURNISHED BY CONTRACTOR:

1. All materials for protective field coatings shall be furnished by Contractor and shall be as specified herein.
2. All materials for pipe supports shall be furnished by Contractor and shall be as indicated.

17G-3 PERFORMANCE:

A. RECEIPT AND UNLOADING OF MATERIALS FURNISHED BY OTHERS:

1. The Contractor shall unload all materials for the circulating water system in conformance with DIVISION 1 and as specified herein.
2. Upon delivery at the plant site and prior to unloading, the 48-inch diameter pipe will be tested for roundness and diameter by the furnishing contractor. The testing will be in the presence of the Engineer and only pipe which is approved by the Engineer shall be unloaded.

B. HANDLING:

1. Handle pipe in a manner to insure installation in sound, undamaged condition using proper equipment, tools, and methods as follows:
 - a. Suitable slings or skids.
 - b. Without hooks in contact with joint surfaces and protective coatings.
 - c. Provisions for preventing contact with adjacent units during moving or storage.
2. Pipe damaged during transporting or handling which, in the opinion of the Engineer, cannot be satisfactorily repaired will be rejected.

C. PIPE INSPECTION AND REPAIR:

1. All pipe shall be subject to the approval of the Engineer.
2. Pipe sections damaged by handling which, in the opinion of the Engineer, cannot be satisfactorily repaired shall be rejected. This shall include, but is not limited to, bent bells and spigots and similar damage.

17G-3 PERFORMANCE: continued

D. CLEANING:

1. Thoroughly clean interior of all pipe, fittings, and joints before installation.
2. Exclude foreign matter during discontinuances of installation as follows:
 - a. Close ends with snug-fitting board containing several small holes near the center.
3. Do not place tools, clothing, or other materials at any time in pipe.
4. Check air in pipe for gas after prolonged periods of enclosure, and replace with fresh air before resuming construction.
5. Visually inspect, remove all struts, and sweep clean or flush clean immediately prior to final fitting of system.

E. FIELD MEASUREMENTS: It shall be the responsibility of the Contractor to make all field measurements necessary to insure installation of all piping as shown and as specified herein.

F. LAYING:

1. Lay pipe according to the plans and laying schedule prepared by pipe manufacturer and as follows:
 - a. Lay pipe such that fittings and other appurtenances are at the required locations.
 - b. Construct field connections true to line, facing, and position without undue strain on the pipe, fittings, and equipment.
 - c. Do not permit laying of pipe in water.
 - d. Perform only when weather conditions are suitable.
 - e. Install steel pipe conforming to AWWA M11.
 - f. Conform to lines and elevations as indicated.
 - g. Install pipe supports as indicated.

G. WELDING OF STEEL PIPE:

1. Field welding shall be in accordance with AWWA C206, and performed only by qualified welders.
2. Field welding procedures utilizing continuous feed self-shielded flux-cored electrode will be allowed as approved by the Engineer.
3. Weld bottom half of pipe from the interior of the pipe for all field butt welds where line size permits reasonable access.
4. Lap weld joints shall be welded inside and outside.
5. Location of field welds is as indicated.

H. PROTECTIVE FIELD COATINGS:

1. Pipe Interior and Exterior Coatings:
 - a. All field weld joints shall be sandblasted to a minimum of SSPC-SP-10 (Near-White Blast Cleaning), after which two coats of Kopper's Bitumastic No. 300-M coal tar epoxy shall be applied in strict accordance with manufacturer's recommendations. A minimum dry thickness of 8.0 mils per coat shall be maintained.

17G-3 PERFORMANCE: continued

- b. Repair all damaged surfaces of interior coating after pipe is installed and all struts have been removed. All damaged surfaces shall be sandblasted and coated as specified herein for field weld joints.
2. Pipe Supports: All steel parts shall be coated as follows:
 - a. Prior to assembly and installation of supports: All surfaces of steel parts shall be sandblasted to a minimum of SSPC-SP-10 (Near-White Blast Cleaning), after which two coats of Kopper's Bitumastic No. 300-M coal tar epoxy shall be applied in strict accordance with manufacturer's recommendations. A minimum dry thickness of 8.0 mils per coat shall be maintained.
 - b. Repair all damaged surfaces of coating after pipe supports are installed. All damaged surfaces shall be sandblasted and coated as specified herein for coatings applied prior to assembly and installation of supports.
3. Steel wall pipes cast in the wall of the cooling tower basin shall be coated as follows:
 - a. Interior of steel wall pipes shall be coated with two coats of Kopper's Bitumastic No. 300-M coal tar epoxy, applied in strict accordance with manufacturer's recommendations. A minimum dry thickness of 8.0 mils per coat shall be maintained.
 - b. For that portion of the steel wall pipes which extend into the cooling tower basin, the exterior shall be coated with Kopper's Bitumastic No. 300M coal tar epoxy as specified herein for interior of steel wall pipes.
4. The Contractor shall furnish all materials for the protective field coatings.
5. Protective field coatings shall be subject to approval of Engineer.

I. FIELD TESTING COMPLETED JOINTS:

1. General:
 - a. Contractor shall furnish all required materials and equipment for the testing.
 - b. All tests shall be performed by the Contractor.
 - c. All equipment, materials, and methods used to perform the tests shall be subject to the approval of the Engineer.
 - d. Joints shall be tested prior to the application of protective field coatings.
 - e. Do not proceed with tests without approval of the Engineer.
2. Butt-welded Joints: All butt-welded field joints shall be tested in accordance with AWWA C206 by means of a vacuum-type look-box.
3. Lap-welded Joints: All lap-welded field joints shall be air tested in accordance with AWWA M11.
4. Repairs: If the tests disclose any leaks the Contractor shall, at his expense:

Potashnik Construction Company
Mr. Leroy Brown

November 14, 1978
Page 6

17G-3 PERFORMANCE: continued

- a. Repair the defective joints.
- b. Repeat the above tests following the repair of defective joints to insure all leakage is eliminated.
5. The pipe will be hydrostatically tested by the Owner after installation of the remainder of the circulating water system.

* * * * *

Drawings: Add UP18 - Circulating Water Piping in Cooling Tower Basin
(copy enclosed with this letter).

The installation of this pipe must be complete by March 15, 1979. Provisions for liquidated damages as called out on pages B-2 and A-2 of the Contract Documents, shall apply to work added by this change order. This change order in no way affects the scheduled completion dates for other parts of the Work.

Please review this change in the Work and submit prior to December 1, 1978, a lump sum proposal for adjustment of the Contract Price. Your proposal shall be accompanied by a quantity takeoff with unit prices.

This letter does not authorize work to proceed on any changes which result in adjustment to the Contract Price. Such authorization may be made by change order subsequent to receipt of your acceptable proposal.

If you have any questions regarding this matter, contact myself or Mr. Bob Petersen of this office.

Sincerely yours,

Jim Azzeh, P.E.

JAA/dap

Enclosures

cc: Mr. E. R. Inman
Mr. M. Hixon (w/enc)
Mr. A. P. Phillips (w/enc)
Mr. R. D. Petersen (w/enc)

DIVISION 18 - ROADS AND DRIVE SURFACING

18A - CRUSHED ROCK SURFACE COURSE

18A-1 GENERAL

A. DESCRIPTION:

1. This Section includes crushed rock surface course and method of depositing for the areas shown on the plans.
2. Related Work Specified Elsewhere:
 - a. Earthwork and Site Preparation: SECTION 2A.

B. QUALITY ASSURANCE:

1. Applicable Standards:
 - a. American Society for Testing and Materials (ASTM):
 - (1) C117 - Test for Materials Finer than No. 200 Sieve in Mineral Aggregate by Washing.
 - (2) C131 - Test for Abrasion of Coarse Aggregates by Use of Los Angeles Machine.
 - (3) C136 - Test for Sieve or Screen Analysis of Fine and Coarse Aggregates.
 - (4) D423 - Test for Liquid Limit of Soils.
 - (5) D424 - Test for Plastic Limit and Plasticity Index of Soils.
 - (6) 1970, 5th Edition, Special Procedures for Testing Soil and Rock for Engineering Purposes:
 - (a) STP-479 - Burmister Method.
 - b. American Association of State Highway and Transportation Officials (AASHTO):
 - (1) T99 - Test for the Moisture Density Relations of Soils Using a 5.5-Pound (2.5 Kg) Rammer and a 12-Inch Drop (305 mm).
 - c. U.S. Department of Interior, Bureau of Reclamation, Earth Manual, 1st Edition.
 - (1) E-12 - Relative Density of Cohesionless Soils Part A.
 - d. Missouri State Highway Department Standard Specifications for Road and Bridge Construction.
 - e. Missouri Standard Specification for Highway Construction.
2. Samples and Testing:
 - a. Tests to determine conformance with all requirements for material quality and properties specified herein will be performed by an independent laboratory approved by the Engineer and compensated by the Contractor.
 - b. Obtain representative samples of material in accordance with ASTM D75 for testing. Furnish Engineer sufficient material for testing from each sample at the time obtained.
 - c. Furnish specific schedule for sampling to provide Engineer the opportunity to observe sampling.
 - d. Quality control testing will be performed during construction by a testing laboratory retained by the Owner.

C. COMPLIANCE SUBMITTALS:

1. Submit as specified in DIVISION 1.
2. Includes, but not limited to, the following:
 - a. Test result reports from testing laboratory indicating conformance with the specifications.
 - b. Certification of conformance with the specification.

18A-2 EQUIPMENT AND MATERIAL

A. GENERAL: Crushed rock base course shall consist of aggregate specified.

B. AGGREGATE:

1. Aggregate shall be crushed stone or crushed gravel, free from lumps or balls of clay or other objectionable matter, and reasonably free from thin and elongated pieces of dirt. Aggregates shall consist of angular fragments, durable and sound, and shall be reasonably uniform in density and quality.
2. Percentage of wear shall not exceed 50 after 500 revolutions as determined by ASTM C131.
3. Aggregate shall contain 75 percent by weight of pieces with two or more fractured surfaces if material is crushed gravel.
4. Portion of aggregate passing No. 40 sieve shall be as follows:
 - a. Liquid Limit: Not more than 25 determined by ASTM D423.
 - b. Plastic Index: Not more than 6 determined by ASTM D424.
5. Gradation shall not vary from low limit on one sieve to high limit on adjacent sieve or vice versa. Test by ASTM C136 and C117, and conform to the following (The Contractor may choose either gradation at his option):

<u>Sieve Designation</u>	<u>Percent by Weight</u> <u>Passing Square-Mesh Sieve</u>	
	<u>No. 1</u>	<u>No. 2</u>
2-inch	-100	-
1½-inch	70-100	-100
1-inch	35-85	70-100
¾-inch	50-80	60-90
⅜-inch	40-70	45-75
No. 4	30-60	30-60
No. 10	15-45	15-45
No. 40	5-25	5-25
No. 200	3-12	3-12

C. EQUIPMENT:

1. General Requirements:
 - a. Maintain all equipment, tools, and machines used in the performance of the work required by this Section in a satisfactory working condition at all times.
 - b. Equipment shall be subject to the approval of the Engineer.
2. Power Rollers:
 - a. Rollers shall be self-propelled, three-wheel, or tandem-type with wheels equipped with adjustable scrapers.
 - b. Weight shall not be less than eight tons.
3. Tamping Rollers:
 - a. Rollers shall consist of one or more units arranged to adapt to uneven ground surfaces.
 - b. Rolling units of multiple type shall be pivoted on the main frame.
 - c. When fully loaded, rollers shall exert at least 300 psi on the combined areas of tamping feet in contact with the ground.
 - d. Each unit shall be equipped with a watertight cylindrical drum with length 48 inches or greater.

18A - CRUSHED ROCK SURFACE COURSE: continued

- e. Tamping feet shall project not less than 7 inches from drum surface, with feet spaced not less than 10 inches, nor more than 10 inches measured diagonally from center to center.
- 4. Rubber-Tired Rollers:
 - a. Rollers shall consist of two axles on which are mounted not less than nine pneumatic-tired wheels, mounted so the rear group of tires do not follow in the tracks of the forward wheels but will be centered between the forward wheels.
 - b. The axles shall be mounted in a rigid frame provided with a loading platform or body suitable for ballast loading.
 - c. Inflate tires uniformly.
 - d. May be self-propelled.
 - e. Tow with pneumatic-tired tractors or other pneumatic-tired equipment.
- 5. Blade Graders shall be self-propelled with a wheelbase of not less than 15 feet, and a blade of not less than 10 feet.
- 6. Sprinkling equipment shall consist of tank trucks, pressure distributors, or other similar equipment designed to apply water uniformly and in controlled quantities to variable width of surface.
- 7. Hauling equipment shall consist of pneumatic-tired vehicles and dump bodies suitable for dumping materials in windrows or layers on the subgrade.
- 8. Tampers shall be mechanical (of an approved type) and hand-operated, weight not less than 50 pounds, and have a face area of not more than 100 square inches.
- 9. Miscellaneous equipment shall consist of scarifiers, tractors, spring-tooth or spike-tooth harrows, windrow equalizers, spreaders, and other equipment suitable for construction of select material base course.

18A-3 PERFORMANCE

A. GENERAL REQUIREMENTS:

- 1. Stockpiles:
 - a. Clear and level storage sites prior to stockpiling.
 - b. Place in the manner and at locations designated by Engineer, providing separate stockpiles for materials from separate sources.
- 2. Cold-Weather Limitations:
 - a. Base-course construction shall be prohibited when atmospheric temperature is below 35 degrees F.
 - b. Do not place base course on frozen subgrade.
 - c. Protect base course and subgrade in freezing weather and repair areas damaged by freezing by reshaping and recompacting.
- 3. Preparation of Subgrade:
 - a. Clean of all foreign substances.
 - b. Correct any ruts or soft yielding spots or any areas with inadequate compaction.
 - c. Engineer will inspect for adequate compaction and surface tolerances.
- 4. Grade Control: Establish and maintain by means of grade stakes placed in lanes parallel to the centerline of the area to be surfaced and spaced so string lines may be stretched between stakes.

18A - CRUSHED ROCK SURFACE COURSE: continued

B. PLACING, SHAPING AND COMPACTION OF MATERIAL:

1. Placing:

- a. Deposit and spread material in a uniform layer and compact to the thickness indicated and as specified below. Spread material uniformly on the prepared subgrade from moving vehicles or spreader boxes.
- b. Level material to the required contour and grades with blade graders.
- c. Remove those portions of the layer which become segregated in spreading and replace with satisfactory material as requested by Engineer.
- d. Hauling, which may prove damaging to the subgrade or surfacing, will be restricted by the Engineer.
- e. Crushed rock surfacing becoming infiltrated with subgrade material shall be removed, with repairs made to the subgrade as required, and replaced with new crushed rock surface.

2. Shaping and Compacting Materials:

- a. Compact in layers no less than three nor more than six inches thick.
- b. Roll to specified compaction requirements throughout full depth of layer with tamping rollers, power rollers, rubber-tired rollers or combination.
- c. Shape and smooth by blading and rolling with power roller or rubber-tired roller, or both.
- d. Hand-tamp in places not accessible to rolling equipment.
- e. Aerate by blade graders, harrows, or other approved equipment when material is moistened by rain.

3. Degree of Compaction:

- a. Base compaction on weight per cubic foot of material passing 3/4-inch sieve and compact to at least 95 percent of maximum density at optimum moisture.
- b. Determine and control compaction in accordance with AASHTO T99 and other applicable standards.

4. Smoothness Test: Shall be as follows (except Construction Parking and Laydown Areas)

- a. Surface shall show no deviation in excess of 3/8-inch in any 10 feet when tested with a 10-foot straightedge applied parallel with and at right angles to the centerlines of the surfaced area.
- b. Correct any deviation in excess of this amount by loosening, adding or removing material, reshaping, watering, and compacting as requested by the Engineer.

C. MAINTENANCE: Maintain finished surface course in a condition satisfactory to the Engineer.

D. WAYBILLS AND DELIVERY TICKETS: Submit daily to the Engineer during progress of work.

* * * * *

18B - BITUMINOUS TACK COAT

18B-1 GENERAL

A. DESCRIPTION:

1. This Section shall consist of the application of liquid bituminous material to a previously laid asphaltic concrete base course.
2. Related Work Specified Elsewhere:
 - a. HOT-MIX ASPHALTIC CONCRETE PAVEMENT - SECTION 18D.
 - b. BITUMINOUS PRIME COAT - SECTION 18C.
 - c. CRUSHED-ROCK BASE AND SURFACE COURSE - SECTION 18A.

B. QUALITY ASSURANCE:

1. Applicable Standards:
 - a. American Society for Testing and Materials (ASTM):
 - (1) D140 - Sampling Bituminous Materials.
 - b. Missouri State Highway Department Standard Specifications for Roads and Bridges (MSHD).
 - c. Missouri Standard Specifications for Highway Construction (MSSHC).
2. Sampling and Testing:
 - a. Tests to determine conformance with all requirements for material quality and properties specified herein will be performed by an independent laboratory approved by the Engineer and compensated by the Contractor.
 - b. Obtain representative samples of material in accordance with ASTM D140 for testing. Furnish Engineer sufficient material for testing from each sample at the time obtained.
 - c. Furnish specific schedule for sampling to provide Engineer the opportunity to observe sampling.
 - d. Quality control testing will be performed during construction by a testing laboratory retained by the Owner.

C. SUBMITTALS:

1. Submit certificates as specified in DIVISION 1.
2. Certificates shall be prepared by a recognized testing laboratory and submitted to Engineer by Contractor for acceptance.
3. Submit for material specified.
4. Submit for each lot of material to be used.

18B-2 EQUIPMENT AND MATERIALS:

A. EQUIPMENT:

1. General Requirements:
 - a. Furnish and maintain all equipment, tools, and machines used in the performance of the Work required by this Section in satisfactory working conditions at all times.
 - b. All equipment designated for use in this Work shall be subject to approval of the Engineer.
2. Bitumen Distributor: Shall meet the same requirements as specified for "Bitumen Distributor," SECTION
3. Power Brooms and Power Blowers shall be of the industrial type and suitable for cleaning prepared bases.

18B - BITUMINOUS TACK COAT continued

B. MATERIAL:

1. Bituminous tack coat shall be Emulsified Asphalt grade SS-1H in accordance with the requirements set forth in MSSHC and MSHD.
2. Material shall be diluted by the addition of water in an equal amount to the original volume of Emulsified Asphalt prior to its use.

18B-3 PERFORMANCE

A. PREPARATION OF SURFACE:

1. Remove all loose and objectionable material from surface.
2. Surface shall be approved by Engineer prior to applying tack coat.
3. Correct any area deemed unsuitable by the Engineer as follows:
 - a. Asphaltic concrete base shall be removed to limits indicated by the Engineer and repaired as specified for "HOT-MIX ASPHALTIC CONCRETE PAVEMENT" SECTION 18D.
 - b. Repair of crushed-rock base, if so directed by the Engineer, shall be as specified for "CRUSHED-ROCK BASE AND SURFACE COURSE," SECTION 18A.
 - c. Repair of subgrade, if so directed by the Engineer, shall be as specified for "SUBGRADE PREPARATION," DIVISION 2, SECTION 2A.

B. APPLICATION OF BITUMINOUS TACK COAT:

1. Apply only when asphaltic base course is dry enough to permit uniform distribution and desired penetration.
2. Apply only when atmospheric temperature is 40 degrees F and rising and stop application when atmospheric temperature is 45 degrees F and falling.
3. Apply by means of an approved bituminous distributor.
4. Tack coat material shall be applied in an amount directed by the Engineer not to exceed 0.25 gallons of mixture per square yard. The rate of application being determined by the Engineer from evaluation of the existing surface.
5. Any spots that are missed in the initial application or any areas develop that do not have a uniform spread or penetration shall be hand sprayed, if so directed by the Engineer.
6. The Engineer may also require rolling with a pneumatic-tired roller to obtain uniformity in the tack coat coverage.
7. Tack coat shall be spread only far enough in advance to permit the construction to progress consistently, uniformly and continuously and shall not be applied so far in advance that the viscous quality will be reduced by traffic prior to placement of asphaltic concrete.
8. If directed by Engineer, areas deemed to have excess bituminous tack shall be blotted with approved material.
9. Tack coat that loses its viscous quality before being covered shall be renewed and any which has been damaged shall be replaced without additional cost to the Owner.

* * * * *

18C - BITUMINOUS PRIME COAT

18C-1 GENERAL

A. DESCRIPTION:

1. This Section shall consist of the application of liquid bituminous material, having penetrating properties, to a prepared granular type base.
2. Related Work Specified Elsewhere:
 - a. Crushed-Rock Base and Surface Course - SECTION 18A.
 - b. Site Preparation and Earthwork - DIVISION 2, SECTION 2A.

B. QUALITY ASSURANCE:

1. Applicable Standards:
 - a. American Society for Testing and Materials (ASTM):
 - (1) D140 - Sampling Bituminous Materials.
 - b. Federal Specifications (FS):
 - (1) SS-A-706c(1) - Asphalt; (For Use In) Road and Pavement Construction.
 - c. Missouri State Highway Department Standard Specifications for Roads and Bridges (MSHD):
 - d. Missouri Standard Specifications for Highway Construction (MSSHC).
2. Samples and Testing:
 - a. Tests to determine conformance with all requirements for material quality and properties specified herein will be performed by an independent laboratory approved by the Engineer and compensated by the Contractor.
 - b. Obtain representative samples of material in accordance with ASTM D140 for testing. Furnish Engineer sufficient material for testing from each sample at the time obtained.
 - c. Furnish specific schedule for sampling to provide Engineer the opportunity to observe sampling.
 - d. Quality control testing will be performed during construction by a testing laboratory retained by the Owner.

C. SUBMITTALS:

1. Compliance Submittals:
 - a. Submit as specified in DIVISION 1.
 - b. Includes, but not limited to, the following:
 - (1) Test result reports from testing laboratory indicating conformance with the specifications.
 - (2) Certification of conformance with the specifications.

18C-2 EQUIPMENT AND MATERIALS

A. EQUIPMENT:

1. General Requirements:
 - a. Furnish and maintain all equipment, tools and machines used in performance of the Work required by this Section in satisfactory working condition at all times.
 - b. All equipment designated for use in this Work shall be subject to approval by the Engineer.
2. Bitumen Distributor:
 - a. Distributor shall be of the pressure type with insulated tanks.

18C - BITUMINOUS PRIME COAT

- b. The use of gravity distributors will not be permitted.
- c. The distributor shall be designed and equipped with the necessary accessories and instruments to provide for the uniform application of bituminous material on various widths of surface at readily determined and controlled rate of 0.05 to 2.0 gallons per square yard.
- d. The maximum allowable variation from any specified rate of application shall not exceed 10 percent.
- e. Distributor and booster tanks shall be so maintained at all times that no dripping of bituminous material will occur from any part of the equipment.
- f. The minimum equipment for an approved distributor truck shall be as follows:
 - (1) A positive displacement-type bitumen pump powered so that uniform distribution of the bituminous material at the rate specified will be obtained. No bypassing of the material to the tank during distribution operations will be permitted. The speed of the pump shall be controlled either by the driver or by the operator on the rear of the truck. A metering device shall be provided to furnish accurate information as to the amount of material being pumped in order to insure accurate control of the spread.
 - (2) A heating device, as an integral part of the truck, which will heat the material to, and maintain it at, the required temperature. The device shall be of a low-pressure type with separate low pressure blower and high-pressure spray nozzle to provide fast and adequate heating before and during the spreading operations.
 - (3) A pump or other device for circulating and agitating the bituminous material during the heating process.
 - (4) Devices and charts to provide for accurate and rapid predetermination and control of the amount of bituminous material being applied, including a tachometer of the auxiliary wheel type, reading speed in feet per minute, and a suitable instrument for recording, in feet, the total distance traveled.
 - (5) A dial indicator, mounted in full view of the operator, that will show accurately the quantity of bituminous material in the tank.
 - (6) An accurate thermometer, mounted on the tank and capable of being read from the ground, that will show the temperature of the bituminous material in the tank.
 - (7) A full circulating swinging spray bar capable of spraying various widths of from 6 inches to at least 12 feet. When extensions are used, they shall also be of the full circulating type. The spray bar shall have a minimum lateral movement to each side of 6 inches and shall have adjustments to permit the surface to be treated from various heights.
 - (8) A pressure gauge, pump tachometer or other approved device for controlling the amount of bituminous material being pumped through the spray bar.
 - (9) A hand hose and nozzle attachment to be used for spotting skipped areas, and areas inaccessible to the distributor.
 - (10) Spray-bar nozzle valves which are operated by levers so that all valves may be quickly opened or closed in one operation by the operator at the rear of the distributor.
 - (11) Dual pneumatic tires. Dual axles will not be permitted unless they are equipped with dual tires.

18C -- BITUMINOUS PRIME COAT

3. Heating Equipment (Storage Tanks):

- a. Steam coils and equipment for producing steam, or approved type retort heater manufactured for heating asphaltic products, at Contractor's option, so designed that steam will not be introduced into the material.
- b. An armored thermometer with a range from 100 to 400 degrees F, fixed to tank in a manner such that it can be easily read from the ground and will continuously indicate temperature of bituminous material.

B. MATERIALS:

1. Bituminous prime coat shall be either RC 250 or RT 2 conforming to the requirements of MSSHC and MSHD.

18C-3 PERFORMANCE:

A. PREPARATION OF SURFACE:

1. Remove all loose and objectionable material from surface.
2. Surface shall be approved by Engineer prior to application of prime coat.
3. Correct any ruts, soft-yielding spots or any other areas deemed unsuitable by the Engineer as follows:
 - a. For subgrade repair as specified for "SUBGRADE PREPARATION," DIVISION 2, SECTION 2A.
 - b. For crushed-rock base course repair as specified for "CRUSHED-ROCK BASE AND SURFACE COURSE," SECTION 18A.
4. Sprinkle surface with water immediately in advance of application of prime coat, if surface is excessively dry.

B. APPLICATION OF BITUMINOUS PRIME COAT:

1. Apply by means of an approved bituminous distributor.
2. Apply bituminous prime coat only when atmospheric temperature in the shade is above 40 degrees F, and the atmospheric and surface conditions are such as will permit satisfactory penetration and adhesion of prime coat.
3. The approximate quantity of bituminous prime to be used shall be 0.50 of a gallon per square yard, with the determination of the exact amount to be used, being made by the Engineer at the time of application.
4. The bituminous prime coat shall be uniformly applied at the rate so designated and in one application.
5. Any spots that are missed in the initial application or any areas develop that do not have a uniform spread or penetration shall be hand sprayed as directed by Engineer.
6. If directed by Engineer, areas deemed to have excess bituminous prime shall be blotted with approved material.
7. Allow primed surface to cure for not less than 48 hours without being disturbed.
8. Traffic shall be kept off the bituminous material until it has cured.
9. Maintain primed surface until the succeeding layer of pavement has been placed.

18C - BITUMINOUS PRIME COAT continued

10. In the event traffic has caused holes or breaks in the primed surface, such holes or breaks shall be repaired, as directed by the Engineer, at no additional expense to the Owner.

* * * * *

18D - HOT-MIX ASPHALTIC CONCRETE PAVEMENT

18D-1 GENERAL

A. DESCRIPTION:

1. This Section includes hot-mix asphaltic concrete pavement materials, equipment, placement, and testing.
2. Related Work Specified Elsewhere:
 - a. Site Preparation and Earthwork: SECTION 2A.
 - b. Bituminous Tack Coat: SECTION 18B.
 - c. Crushed Rock Base Course: SECTION 18A.
 - d. Bituminous Prime Coat: SECTION 18C.

B. QUALITY ASSURANCE:

1. Applicable Standards:
 - a. American Society for Testing and Materials (ASTM):
 - (1) C29 - Test for Unit Weight of Aggregate.
 - (2) C117 - Test for Materials Finer than No. 200 Sieve in Mineral Aggregates by Washing.
 - (3) C127 - Test for Specific Gravity and Absorption of Coarse Aggregate.
 - (4) C128 - Test for Specific Gravity and Absorption of Fine Aggregate.
 - (5) C131 - Test for Abrasion of Coarse Aggregate by Use of the Los Angeles Machine.
 - (6) C136 - Test for Sieve or Screen Analysis of Fine and Coarse Aggregate.
 - (7) C183 - Sampling Hydraulic Cement.
 - (8) D75 - Sampling Stone, Slag, Gravel, Sand, and Stone Block for Use as Highway Materials.
 - (9) D140 - Sampling Bituminous Materials.
 - (10) D242 - Mineral Filler for Sheet Asphalt and Bituminous Concrete Pavements.
 - (11) D1559 - Resistance to Plastic Flow of Bituminous Mixtures Using Marshall Apparatus.
 - b. American Association of State Highway and Transportation Officials (AASHTO):
 - (1) M29 - Sand for Bituminous Mixtures.
 - (2) T101 - Standard Method of Determining Swell Characteristics of Aggregates when Mixed with Bituminous Materials.
 - (3) T102 - Spot Test of Asphaltic Materials.
 - c. Federal Specifications (FS):
 - (1) SS-A-706C(1) - Asphalt; (For Use In) Road and Pavement Construction.
 - d. Missouri State Highway Department Standard Specifications for Roads and Bridges (MSHD).
 - e. Missouri Standard Specifications for Highway Construction (MSSHHC).

C. SUBMITTALS:

1. Samples: Furnish samples as specified. Samples shall be delivered to the laboratory designated by the Engineer. Sampling shall be under the observation of the Engineer when required.
 - a. Furnish samples of all materials to be used in the Work at least 30 days prior to beginning production of asphalt paving mixture. Sampling methods shall conform to the following:
 - (1) Asphalt cement: ASTM D140.

18D - HOT-MIX ASPHALTIC CONCRETE PAVEMENT: continued

- (2) Coarse and Fine Aggregates: ASTM D75.
- (3) Mineral Filler: ASTM C183, paragraphs 3, 4, and 6.

b. Furnish additional samples prior to and during construction of the number and size requested by the Engineer.

2. Job-Mix Formula:

- a. Formula shall indicate the definite percentage of each sieve fraction, percentage of asphalt, and the temperature of the completed mixture as it is to be discharged from the mixer.
- b. Formula shall be furnished by Contractor 30 days prior to beginning production of paving mixtures, and approved by Engineer following testing of the aggregates and bitumen before any bituminous mixtures are manufactured.
- c. Formula shall permit adjustments of the bitumen content and aggregate gradation within the limits of the gradation table specified to improve the paving mixtures as required by Engineer.
- d. Restrict formula to values such that application of the following tolerances will not cause the limits in the gradation table to be exceeded.

<u>Material</u>	<u>Base Course</u>	<u>Surface Course</u>
Aggregate passing No. 4 sieve or larger	±5 percent	±4 percent
Aggregate passing No. 10, 40, and 80 sieves	±4 percent	±3 percent
Aggregate passing No. 200 sieve	±1.5 percent	±1.5 percent
Asphalt	±0.3 percent	±0.3 percent
Temperature of mixing	±25 degrees	±25 degrees

D. JOB CONDITIONS:

- 1. Weather Limitations: Hot-mix asphaltic concrete shall not be mixed or placed when the ambient temperature is below 40 degrees F.

18D-2 EQUIPMENT AND MATERIALS

A. EQUIPMENT: Equipment for mixing, transporting, placing and compacting of bituminous concrete material shall conform to requirements of MSSHC section 403 and the approval of the Engineer.

B. MATERIALS:

- 1. General: All materials shall be subject to final approval of the Engineer.
- 2. Aggregates:
 - a. Coarse aggregates shall meet the requirements of MSSHC section 1002.
 - b. Fine aggregate shall meet the requirements of MSSHC section 1002.
- 3. Bituminous Materials: Shall meet the requirements of MSSCH section 1015.

C. MIXES:

- 1. Aggregate Gradations: Gradation of aggregate shall be determined conforming to ASTM C117 and C136.

18D - HOT-MIX ASPHALTIC CONCRETE PAVEMENT: continued

2. Aggregate shall be uniformly graded from fine to coarse, shall not vary from the low limit on one sieve to the high limit on the adjacent sieve and shall conform to the following gradations:
 - a. Bituminous Concrete Base Course: Gradations shall conform to requirements set forth in MSSHC Section 301.
 - b. Bituminous Concrete Surface Course: Gradations shall conform to requirements set forth in MSSHC Section 401 for Grade D.
3. The proportion of bitumen to total aggregate by weight will be within the following limits with the exact content to be determined by the job mix formula:
 - a. Bituminous Concrete Base Course: 3-6 percent.
 - b. Bituminous Concrete Surface Course: 3.5-8 percent.
4. Mixture Test Properties: Laboratory test specimens of the paving mix, combined in proportions of the job-mix formula, will be tested by the Engineer in accordance with ASTM D1559. Test properties shall be as follows for all paving mixtures:
 - Marshall Stability 1200 minimum
 - Number of compaction blows 50
 - Marshall flow 8-16
 - Percent air voids - laboratory specimen
 - Base course 3-8
 - Surface 3-5
 - Percent voids filled with asphalt
 - Base course 65-72
 - Surface 75-82

18D-3 PERFORMANCE

A. PREPARATION OF MIXTURE:

1. Hot-mix asphaltic concrete shall be produced in a mixing plant conforming to MSSHC Section 401.
 - a. Preparation of mixture shall be as specified in MSSHC Section 401.
 - b. Temperature of the mix as it is discharged from the mixer shall be 310 degrees F. Tolerances shall be as specified in MSSHC Section 401.

B. TRANSPORTATION OF MIXTURE:

1. Haul trucks shall be as specified in MSSHC Section 401. Provide trucks of such size, operating speed, and condition to insure orderly and continuous operation.
2. When necessary to prevent adhesion of mixture to truck beds, coat truck beds with a minimum quantity of paraffin oil, lime solution, or other approved material.
3. Haul trucks shall make no direct frame contact with the paver, and shall not bear down on the paver during dumping operations.
4. Deliveries shall be made so that spreading and rolling of all the mixture prepared for a day's run can be completed during daylight.
5. Deliver to the area to be paved in such a manner that the temperature at the time of dumping into the spreader will not be less than herein-after specified.

18D - HOT-MIX ASPHALTIC CONCRETE PAVEMENT: continued

6. Hauling over freshly laid material will not be permitted.
7. Loads wet excessively by rain will be rejected.

C. PLACING MIXTURE:

1. Underlying Course:
 - a. Clean of all foreign or objectionable matter with power blowers, power brooms, or hand brooms as approved by the Engineer.
 - b. Prepare as specified in SECTION 18B.
2. Temperature of Mixture shall be within the range determined by Engineer and not be less than 235 degrees F when dumped into the mechanical spreader or it will be rejected.
3. Automatic screed controls shall be actuated by the following grade references installed by Contractor:
 - a. An erected stringline on each side of the first lane placed in each course, independently actuating screed control mechanisms on each side of the paver.
 - b. A traveling stringline operated on the adjacent completed lane, and an erected stringline on the subgrade or previously completed pavement course, independently actuating screed control mechanism on each side of the paver for the second and all successive lanes of each course.
 - c. Erected stringlines will be required on only one side of the first paving lane of each course for all pavements having a width of 24 feet or less providing automatic slope controls produce finish transverse slopes within the specified tolerances for smoothness and grade.
 - d. Joint matching shoes operating on previously completed gutter sections shall be used for control reference on all paving lanes adjacent to curb-and-gutter sections.
4. Adjust spreader and regulate speed so the surface of the course is smooth and of such depth that when compacted it will conform to the cross section, grade, and contour as indicated.
5. Paving Strips:
 - a. Begin along centerline of areas to be paved on a crowned section and on high side of a section of an area with a one-way slope.
 - b. Place in strips with a minimum width of 10 feet.
 - c. Roll, leaving a 6-inch unrolled strip adjacent to the area on which additional material is to be laid, except when the work is to be discontinued.
 - d. Place strips in succeeding order while the unrolled 6-inch section of the adjoining strip is hot and in a readily compactable condition, and roll.
 - e. Paving strips shall be of such length as determined by Engineer, before placing the succeeding strips.
 - f. Place material as nearly continuous as possible.
 - g. Paving strips shall be as approved by Engineer where necessary to maintain traffic flow.
6. Handwork:
 - a. Use a sufficient number of experienced shovelers, rakers, following the spreading machine to produce a course that will conform to all requirements specified.

18D - HOT-MIX ASPHALTIC CONCRETE PAVEMENT: continued

- b. In areas where use of machine spreading is impractical, place mixture on dumpboards outside the area to be paved, distribute by hot shovels and spread with hot rakes in a uniformly loose layer of such thickness that when compacted it will conform to the required grade and thickness.
 - c. Rakers shall not be permitted to stand in hot mix without stilt sandals.
7. Contact Surfaces:
- a. Defined as previously constructed pavement curbs, manholes and similar structures.
 - b. Coat with a thin coat of hot bituminous material prior to placing the bituminous mixture.
- D. COMPACTION OF MIXTURES:
- 1. Rollers:
 - a. Use three-wheeled, pneumatic and steel-wheeled rollers specified. Vibratory rollers may be used where approved by the Engineer.
 - b. Begin as soon after placing as mixture will bear the roller without undue displacement. Delays in rolling freshly-spread mixture will not be permitted.
 - 2. Operation of Rollers:
 - a. Only competent and experienced men shall operate rollers.
 - b. Do not exceed speeds of 3 miles per hour for steel-wheeled rollers and 5 miles per hour for pneumatic rollers, and at all times speed shall be slow enough to avoid displacement of the hot mixture.
 - c. Moisten wheels to prevent adhesion of the mixture to the wheels, but an excess of water will not be permitted.
 - d. Provide a minimum of one steel-wheeled roller and one pneumatic roller for each spreading machine in operation, with additional 10-ton rollers added if it is found that the pavement density specified is not obtained by the minimum number of rollers.
 - e. Pass over the unprotected edge of the course only when the laying of the course is to be discontinued for such length of time as to permit the mixture to become cold.
 - 3. Rolling Order: Roll pavement in the following order:
 - a. Transverse joints.
 - b. Longitudinal joints at adjacent completed paving lane or curb-and-gutter section.
 - c. Outside edge of first and last paving lanes not adjacent to completed pavement or curb-and-gutter sections.
 - d. Breakdown rolling beginning on the low side and progressing toward the high side.
 - e. Second rolling beginning at the low side and progressing toward the high side.
 - f. Finish rolling.
 - 4. Joint Rolling:
 - a. Roll joints directly behind the paving operation.
 - b. Make first pass with approximately a 6-inch width of roll on the joint and the remainder supported by the previously completed mat.

18D - HOT-MIX ASPHALTIC CONCRETE PAVEMENT: continued

- c. Shift position of roll on joint in 6- to 8-inch increments on successive passes and continue rolling until a thoroughly compacted neat joint is obtained.
 5. Breakdown Rolling:
 - a. Use either steel-wheeled or pneumatic rollers.
 - b. Operate with drive wheels or rolls nearest the paver.
 - c. Roll as close to the paver as possible without causing undue displacement of the mat.
 6. Second Rolling:
 - a. Use pneumatic or vibratory rollers specified.
 - b. Accomplish while paving mix is still at a temperature that will result in maximum density and following breakdown rolling as closely as possible.
 - c. Continue rolling until the mix is thoroughly and uniformly compacted to the specified density but make not less than three complete coverages of the mat.
 7. Finish Rolling:
 - a. Use two-axle or three-axle tandem rollers specified.
 - b. Roll while mat is of sufficient temperature to permit removal of roller marks.
 - c. Continue rolling until all roller marks have been removed and a uniform surface texture is obtained.
 8. Hand Tampers:
 - a. Use in all places not accessible to the rollers.
 - b. Weight of tamper shall not be less than 25 pounds, with a tamping face of not more than 50 square inches.
 - c. Use while mixture is hot.
 9. Repair:
 - a. Repair any mixture that becomes mixed with foreign material or is in any way defective.
 - b. Remove and replace with fresh mixture and compact to the density of the surrounding area.
 - c. Do not skin-patch an area that has been rolled.
- E. JOINTS:
1. General Requirements:
 - a. Joints shall present the same texture, density, and smoothness as other sections of the course.
 - b. Carefully make joints in such manner as to insure a continuous bond between the contact surface of the course.
 - c. Paint with a thin, uniform coat of hot bituminous material just before the fresh mixture is placed on all contact surfaces of previously constructed pavements.
 - d. Place so that the joint will not coincide with that of the lower course or courses, but will be offset at least one foot.
 2. Transverse Joints:
 - a. Pass roller over the unprotected end of freshly laid mixture only when the laying of the course is to be discontinued or when delivery of mixture is interrupted to the extent that the unrolled material may become cold.

18D - HOT-MIX ASPHALTIC CONCRETE PAVEMENT: continued

- b. Cut back previously laid course to expose an even, vertical surface for the full thickness of the course.
 - c. Rake fresh material against the joint, thoroughly tamping with hot tampers, and smoothing with hot smoothers, followed by rolling.
3. Longitudinal Joints:
- a. Cut back edge to expose an even vertical surface for the full thickness of the previously laid course prior to constructing the adjacent pavement.
 - b. Rake fresh mixture against the joint, thoroughly tamping with hot tampers and smoothing with hot smoothers, followed by rolling.
 - c. Joints shall not be irregular, honeycombed, or poorly compacted.
- F. PROTECTION OF PAVEMENT:
- 1. Protect pavement from all vehicular traffic of any kind until it has cooled and hardened, and in no case less than six hours.
- G. SURFACE SMOOTHNESS:
- 1. Tests:
 - a. Make tests after completion of the final rolling.
 - b. Correct the irregularities that exceed the specified tolerances or that retain water on the surface, as requested by Engineer.
 - 2. Tolerances:
 - a. Measure with a 10-foot straightedge, applied both parallel and at right angles to the centerline of the paved area.
 - b. Smoothness tolerances shall be:
 - (1) Surface course - $\pm 1/8$ -inch.
 - (2) Base course - $\pm 1/4$ -inch.
- H. DENSITY:
- 1. Density of completed base course pavement shall be equal to or greater than following percentage of the density of a laboratory specimen made from the same day's mixture and compacted in accordance with ASTM D1559.
 - a. Base course - 95 percent.
 - b. Surface and binder courses - 97 percent.
- I. FIELD LABORATORY:
- 1. Provide a room or building at the plant site for the exclusive use of Engineer.
 - 2. Size shall be not less than 100 square feet of floor area with least dimension not less than 6 feet.
 - 3. Provide 110-volt, 60-cycle, single-phase electrical service to not less than one duplex convenience outlet and one overhead incandescent or fluorescent lamp.
 - 4. Furnish laboratory sieves required for gradation analysis of all specified aggregates, powered shaker device, laboratory balance and standard weights, and extractor.

18D - HOT-MIX ASPHALTIC CONCRETE PAVEMENT: continued

J. WAYBILLS AND DELIVERY TICKETS:

1. Submit waybills and delivery tickets to Engineer for each load of paving mixture placed in completed portions of the project.
 - a. Submit at the end of each day pavement is placed.
 - b. Submit as each load is dumped in the hopper of the paver when requested by Engineer.
2. Submit waybills and refinery analysis for each load of bituminous material on the day received.
 - a. Certificates shall indicate:
 - (1) Penetration.
 - (2) Specific gravity.
 - (3) Temperature.
 - (4) Net weight or gallonage of shipment.

* * * * *

18E - GUARDRAIL:

1. Applicable Standards: Shall be the latest revision and supplements of the American Association of State Highway Officials (AASHTO):
 - a. M-111 - Zinc (Hot-Galvanized) Coatings on Products Fabricated From Rolled, Pressed, and Forged Steel Shapes, Plates, Bars, and Strip.
 - b. M-180 - Corrugated Sheet Steel Beams for Highway Guardrail.

2. Guardrail Materials:
 - a. Rail: Shall conform to AASHTO M-180, with the following specific requirements:
 - (1) Guardrail shall be Class B guardrail, galvanized after fabrication with at least 2.0 ounces per square foot of spelter, total for both sides, conforming to AASHTO M-111.
 - (2) Fit each end of every installation with a terminal section. Lap terminal sections and splices in the direction of traffic.
 - (3) Shop-bend guardrail for curved sections where the radius of curvature is less than 150 feet.
 - b. Posts: Shall meet the following specific requirements:
 - (1) Posts shall be W6x8.5 galvanized beams.
 - (2) Posts shall meet material requirements specified in Division 5.

3. Erection:
 - a. Install in locations indicated.
 - b. Space posts a maximum of 6'-3" on centers, and embed as indicated on Dwg Y-58.
 - c. Set posts vertically, accurately align in position, grade and backfill in layers not exceeding six inches with suitable material, and thoroughly ram earth.

* * * * *